

Q72414  
1/72

## Tempest Late Type Wheels

for Airfix kit



PUR - Polyurethane parts



© Special Hobby 2024

Díly ohnuté popř. pokroucené vlivem teplotních změn a stárnutí materiálu, mohou být narovnané do požadovaného tvaru pomocí proudu teplé vody nebo vzduchu (fén na vlasy). K lepení použít kyanoakrylátové lepidlo! Kontaktní plochy doporučujeme před lepením odmastit. Různé drátky a tyčinky nejsou přiloženy.

*Parts slightly distorted and bent owing to temperature changes or due to material aging can be straightened to requested shape by hot water or hot air jet (hair dryer). This process can be repeated till result is entirely satisfactory. For best result use cyanoacrylate glue!*

*Ungreasing contact areas is recommended before gluing.  
Wires and rods not included.*

Visit our official website and e-shop at  
[www.cmkkits.com](http://www.cmkkits.com)  
[www.specialhobby.eu](http://www.specialhobby.eu)  
[www.facebook.com/specialhobby/](https://www.facebook.com/specialhobby/)

## H1020 Razor Saw Profi Set

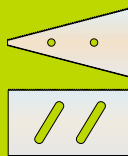

The set contains  
one holder, one  
H1018 Triangle Razor  
Saw and one H1019  
Multi-shift Razor Saw.  
Attach the razor blade to  
the holder as shown in the  
pictures using the plate with  
holes and screws.

Special Hobby, Mezilesí 718, 793 00, Praha 9 - CZ,  
e-mail.: [office@specialhobby.eu](mailto:office@specialhobby.eu)

Aluminium  
Hliník

PUR1

Tire black  
barva pneu

PUR1

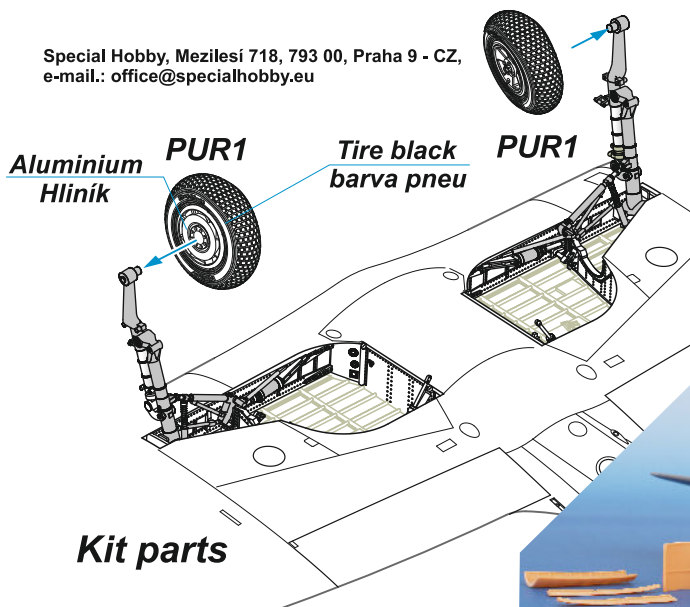

Kit parts

Our range of sets for the 1/72 Tempest Mk.V (Airfix kits) is extensive. We offer not only Q72414 Tempest Mk.V Late Type Wheels, but also other sets:

- 129-F72402 Tempest Pilot, Dog and Mechanic with Accumulator Trolley
- 129-P72008 Tempest Mk.V Engine and Fuselage Tanks
- 129-P72009 Tempests Early Gun Barrels
- 129-P72010 Tempest Mk.V Gun Sight and Seat Correction Set
- 129-P72011 Tempest Mk.V Exhausts
- 129-Q72413 Tempest/Typhoon Early type Wheels

Note:  
P72XXX - 3D printed sets  
Q72XXX - resin cast set (printed master)

