

Krytování kabiny / Canopy of cockpit

**CMK NEW ITEM SETS 1/48 and publications**

- 4220 TSR-2 Interior set for Airfix kit
- 4222 TSR-2 Nose undercarriage bay set for Airfix kit
- 4223 TSR-2 Equipment set for Airfix kit
- 4224 TSR-2 Exhausts nozzles set for Airfix kit
- 4225 TSR-2 Airbrakes set for Airfix kit
- 4226 TSR-2 Undercarriage bays set for Airfix kit
- 4227 TSR-2 Undercarriage legs set for Airfix kit
- 4228 TSR-2 Control surfaces set for Airfix kit
- 4229 TSR-2 Wheels set for Airfix kit
- 1004 TSR-2 Photo Hobby Manual (CMK Publications)
- Q48 079 TSR-2 FOD set for Airfix kit
- Q48 080 TSR-2 Ejection seats (2 pcs) for Airfix kit

Díly ohnuté popř. pokroucené vlivem teplotních změn a stárnutí materiálu, mohou být narovnané do požadovaného tvaru pomocí proudu teplé vody nebo vzduchu (fén na vlasy). Různé drátky a tyčinky nejsou přiloženy. K lepení použijte kyanoakrylátové lepidlo. Kontaktní plochy doporučujeme před lepením odmastit.

Parts slightly distorted and bended owing to temperature changes or due to material ageing can be straightened to requested shape by hot water or hot air jet (hair dryer). Wires and holes not included. This process can be repeated till result is entirely satisfactory. For best results gluing use cyanoacrylate glue. Contact areas ungrease is recommended before gluing

**BARVY - COLORS**

- A** Bílá / White 22
- B** Černá / Black 33

**HUMBROL**

- C** Stříbrná / Silver 11
- D** Šedá / Grey 140



Visit an official website and e-shop at [www.cmkkits.com](http://www.cmkkits.com)

No 4220

1/48

**TSR - 2 Interior set for AIRFIX kit**

**PUR (polyuretan parts)**

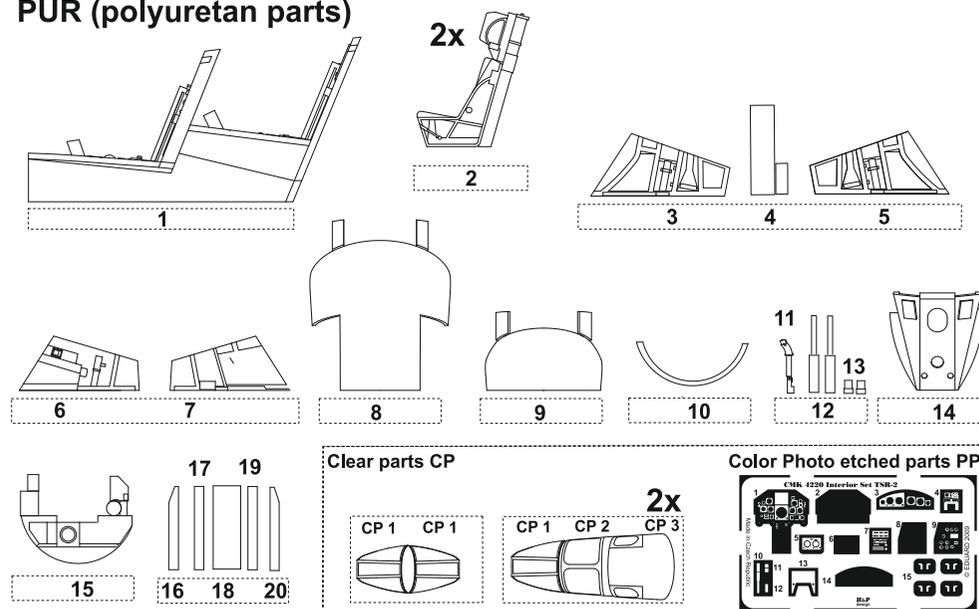

**1 Sestavení přístrojové desky pilota / Pilot's instrument panel assembly**

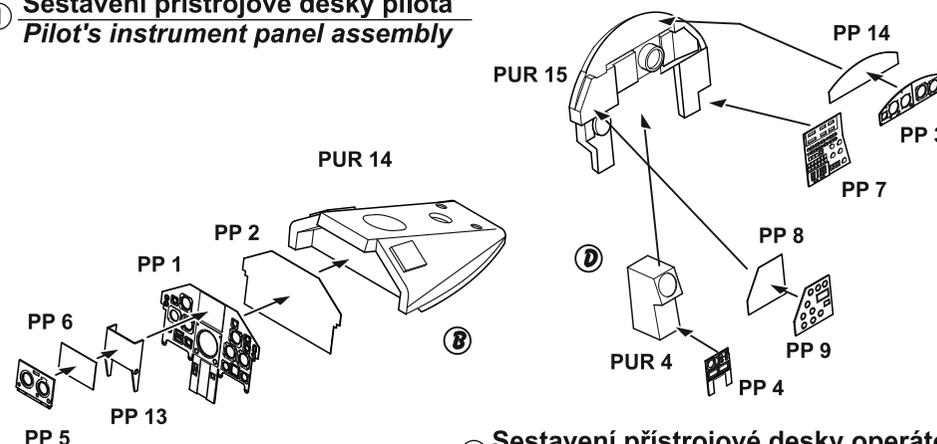

**2 Sestavení přístrojové desky operátora / Operator's instrument panel assembly**

### ③ Sestavení kokpitu / Cockpit assembly

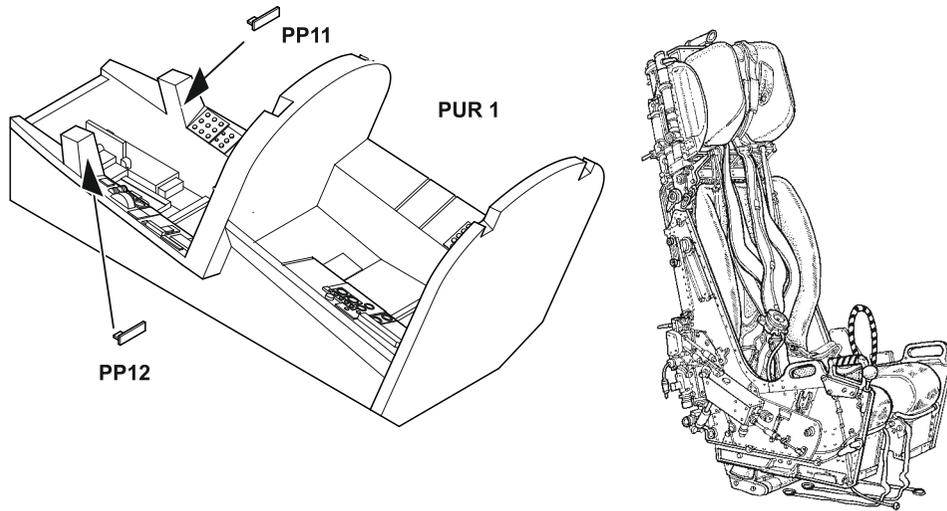

### ④ Dokončení kokpitu / Final cockpit assembly

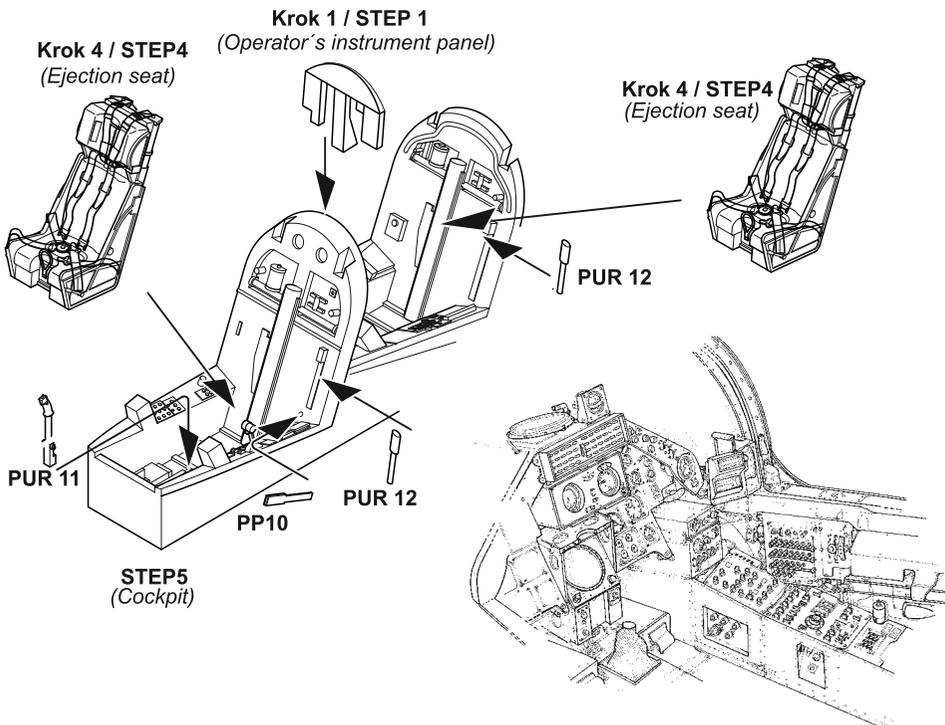

### ⑤ Sestavení trupu / Fuselage assembly

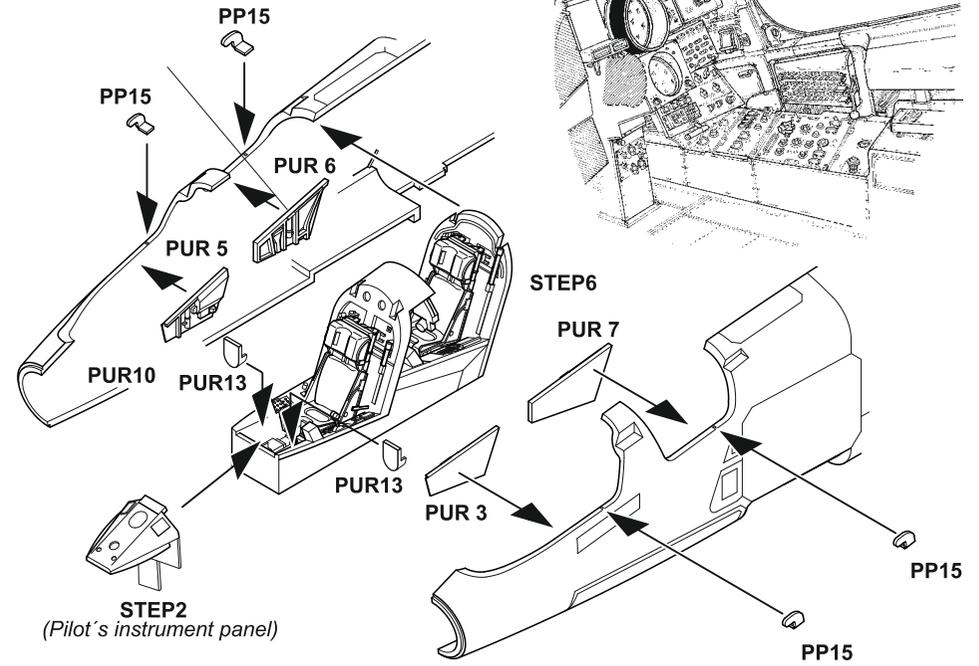

### ⑥ Překrytí kabiny / Canopies

Díly 3x CP 1, 1x CP 2 a 1x CP 3 jsou rezervní / Spare parts 3x CP 1, 1x CP 2 and 1x CP 3

