

## T-2 Buckeye 'Anniversary Markings'

### CZ

Od roku 1959, kdy vstoupil do služby, až do roku 2004, kdy byl North American T-2 Buckeye vyřazen z výcvikového programu, byl prvním proudovým strojem námořnictva USA, na kterém létali do výcviku zařazení letci. US Navy objednalo tento letoun v roce 1956, s tím, že v rámci několikastupňového výcviku bude zařazen za vrtulový T-28 Trojan. Sloužil k seznámení s proudovou technikou před přechodem na bojové stroje.

První prototyp označený YT-2J-1 vzlétl 31. 1. 1958. První verze T2J-1 byla jednomotorová. Poháněl ji motor J34-WE-48. Této verze bylo postaveno 201 kusů, od roku 1962 byla v novém systému označování přeznačena na T-2A.

US Navy požadovalo úpravu na dvumotorový stroj s větší bezpečností. Proto North American připravil a zavedl do výroby verzi T-2B se dvěma motory J60-P-4. Postaveno bylo 97 kusů, poté výroba přešla na verzi T-2C s motory J85-GE-4.

Té bylo postaveno 231 kusů. Bojové jméno společné pro všechny verze bylo Buckeye - jírovec neboli kaštan.

T-2 Byly vyráběny v Columbusu v Ohiu a jírovec je státním stromem státu Ohio. Na konci své služby u US Navy byla část strojů upravena na terčové a označena DT-2B nebo DT-2C.

Kromě toho, že T-2 sloužily skoro padesát let k výcviku letců US Navy, byly také exportovány. Verzi označovanou T-2D odebralo letectvo Venezuely, T-2E složí v Řeckém vojenském letectvu.

V USA nyní létá několik T-2 jako soukromé jety.

rozpětí: 11,6 m, délka: 11,8 m, max. rychlost v úrovni moře: 862 km/h, dolet: 1723 km, dostup: 13 045 m

### EN

North American T-2 Buckeye was the first US Navy jet trainer aircraft since 1959 when it entered service until 2004 when it was withdrawn from pilots' training program. It was ordered by the US Navy in 1956 as intermediate trainer for training conversion from T-28 Trojans. It served for jet powered aircraft familiarization prior conversion to combat aircraft.

The first prototype YT-2J-1 took off on January 1, 1958. The first version T2J-1 was powered by single J34-WE-48 jet engine. 201 machines of this version were produced and since 1962 when new designation system was introduced the aircraft was re-designated to T-2A.

For better safety the US Navy demanded the aircraft to be powered by two jet engines. Therefore North American designed and introduced T-2B version powered by two J60-P-4 jet engines. 97 machines of this version were produced and then the production switched to T-2C version powered by two J85-GE-4 jet engines.

T-2C was produced in 231 pieces. The combat name common to all versions was Buckeye - Ohio chestnut tree. T-2s were produced in Columbus Ohio and the buckeye is the Ohio's state tree. At the end of its career some US Navy machines were converted for target towing and re-designated DT-2B or DT-2C.

Except of the fact that T-2s served for training almost half a century they were also exported. T-2D was purchased by the Venezuelan Air Force; T-2E still serves with the Hellenic Air Force.

Several T-2s are in private hands in the USA.

Wingspan: 11.6 m, Length: 11.8 m, Max. Speed at sea level: 862 km/h, Range: 1,723 km,  
Service Ceiling: 13,045 m.

# PLASTIC PARTS

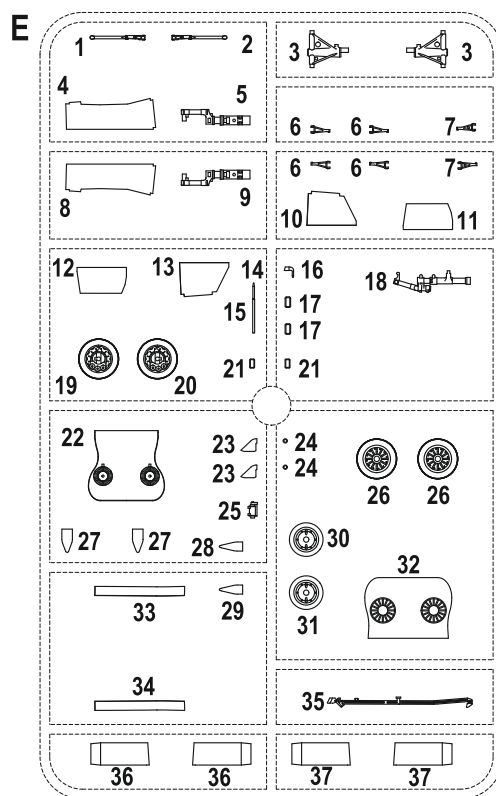
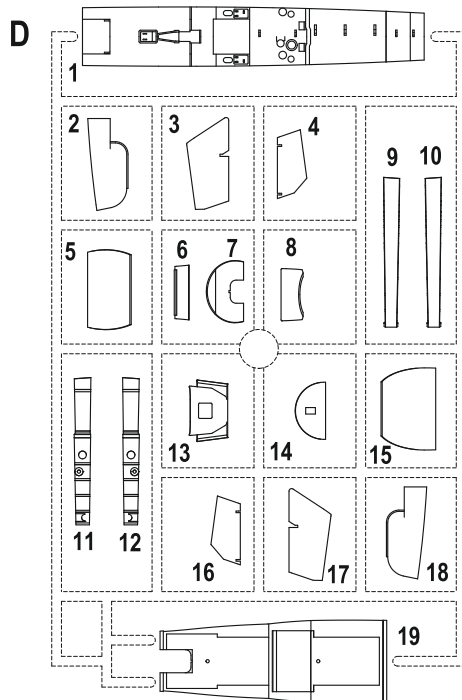
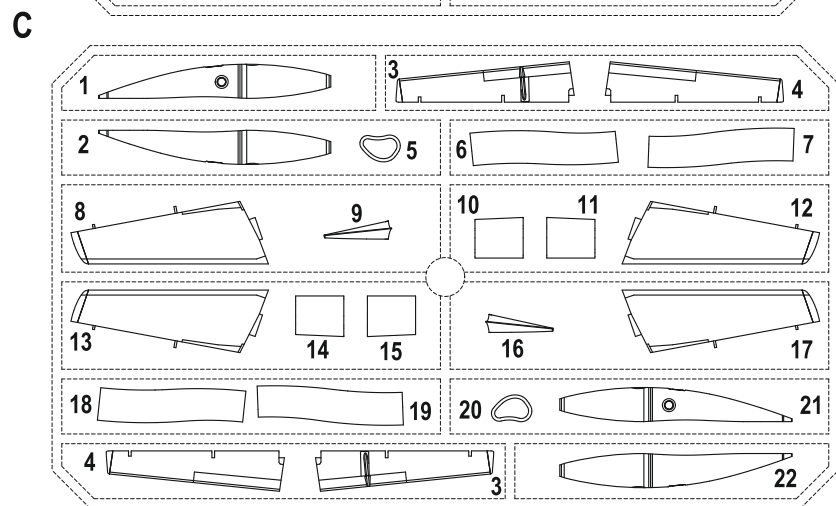
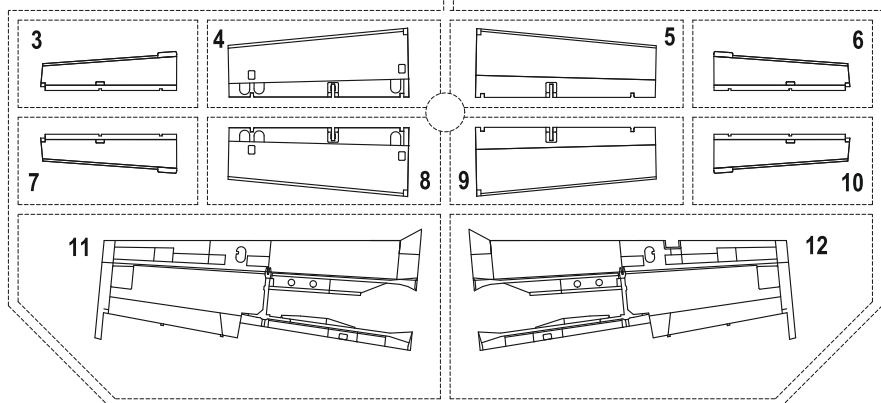
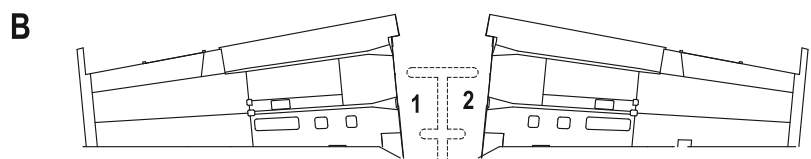
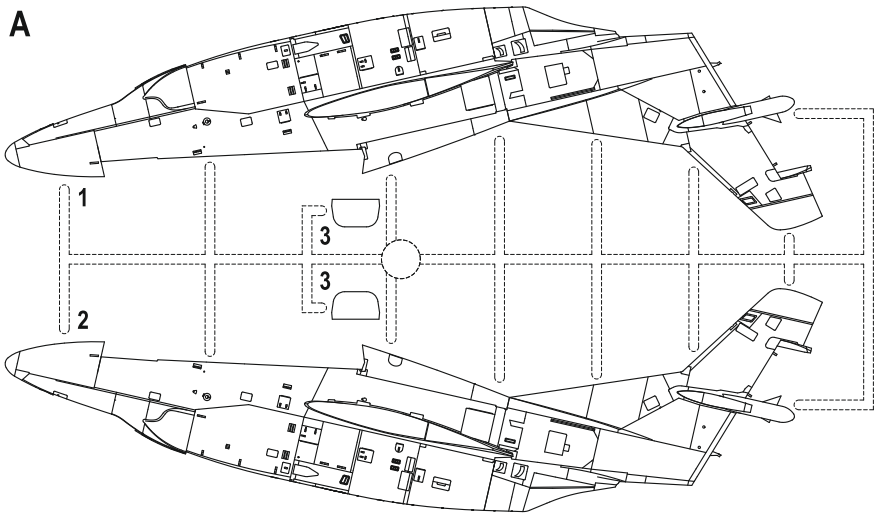

## CLEAR PARTS (CP)

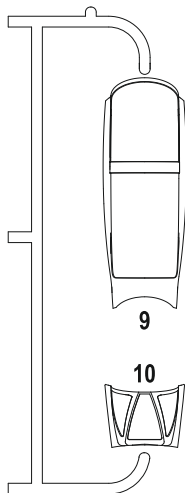
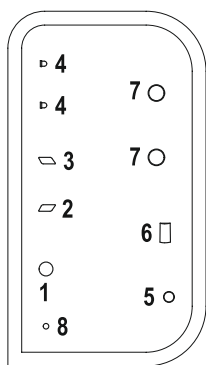

## PHOTO-ETCHED PARTS (L)

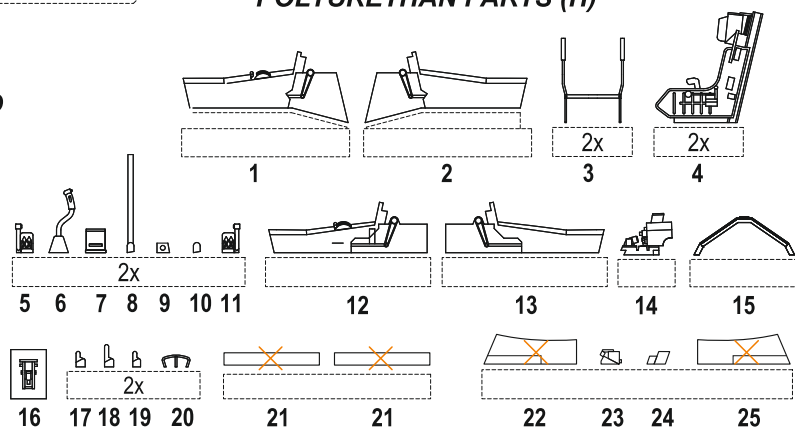
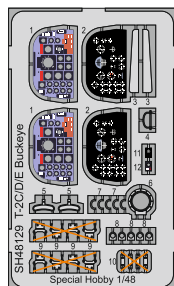

**X** Tento díl nepoužít  
Do not use this part

1

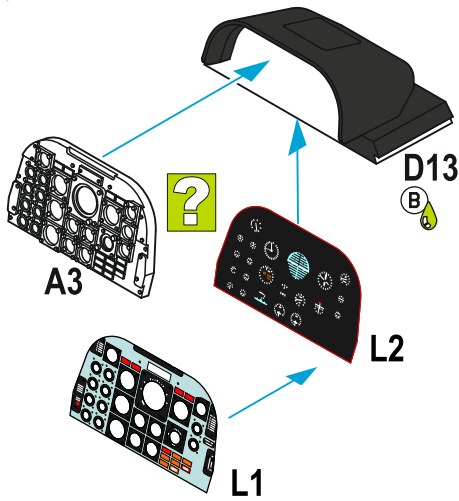

2

Assembly

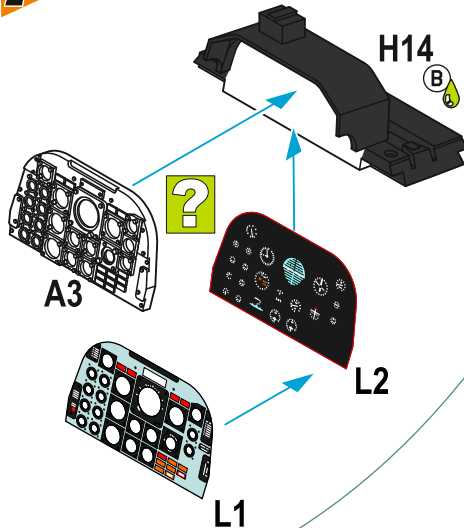

3

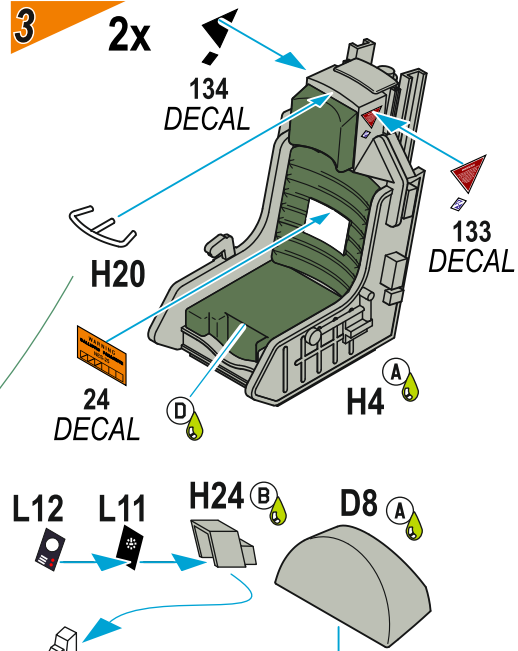

COLOUR NOTES:

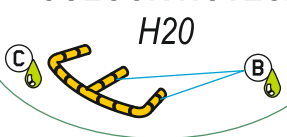

4

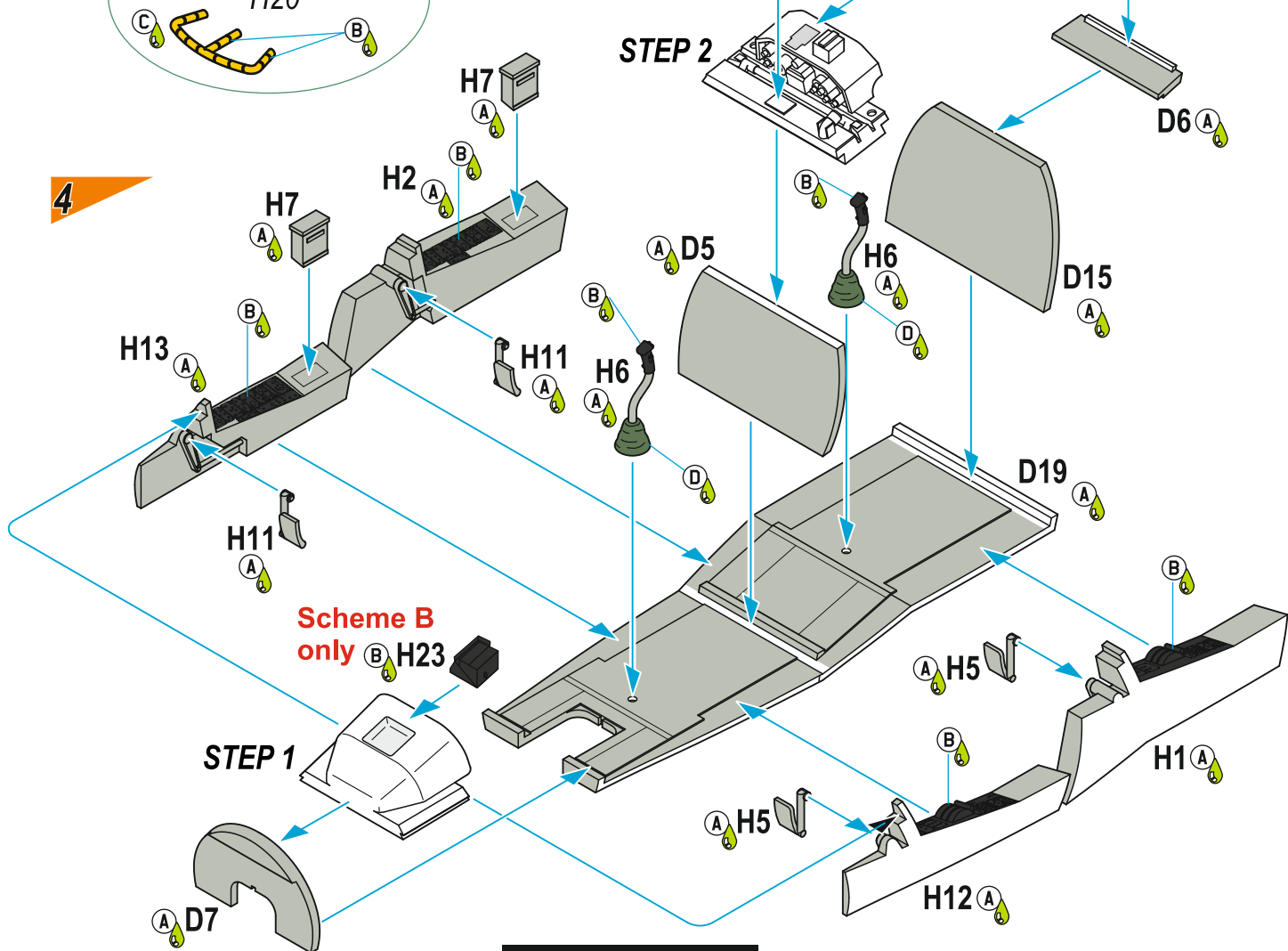

Barvy GUNZE / GUNZE Colour No.			
(A) Světle šedá / Light Grey	H325 / C325	(F) Ocelová / Steel	H18 / C8
(B) Černá / Black	H12 / C33	(G) Barva pneu / Tire Black	H77 / C137
(C) Žlutá / Yellow	H4 / C4	(H) Chromová stříbrná / Chrome Silver	MC211
(D) Šedozelená / Grey-Green	H336 / C336	(I) Opálený kov / Burnt Iron	H76 / C61
(E) Bílá / White	H1 / C1		

SYMBOLS

- MOŽNOST VOLBY  
OPTIONAL  
NACH BELIEBEN  
OPTION
- POUŽIT KYANOAKRYLÁTOVÉ LEPIDLO  
INSTANT CYANOACRYLATE GLUE  
ZYANOAKRYLATKLEBER  
COLLE CYANOACRYLAT
- OHNOUT  
BEND  
BIEGEN  
COURBER
- ZHOTOVIT NOVÉ  
SCRATCH BUILD  
FERTIGSTELLEN  
ACHEVER
- ŘEZAT/VRTAT  
CUT OFF/DRILL  
ENTFERNEN  
DETACHER
- GSI  
colour code
- NATRÍT  
COLOUR  
FARBEN  
PEINDRE

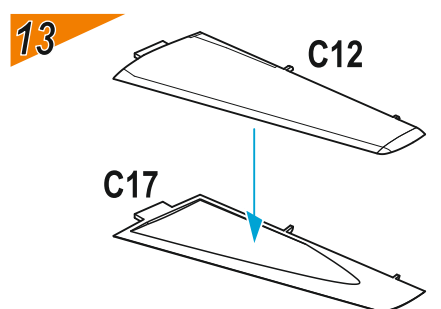
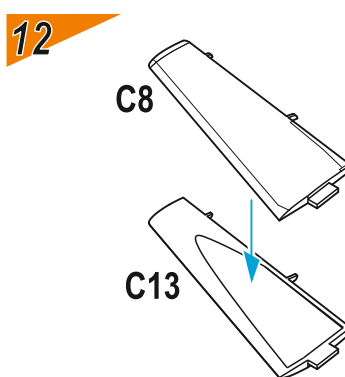
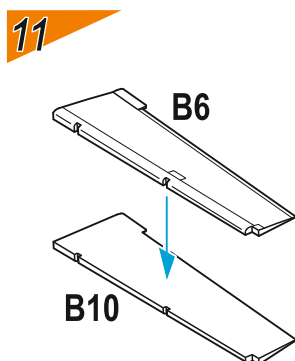
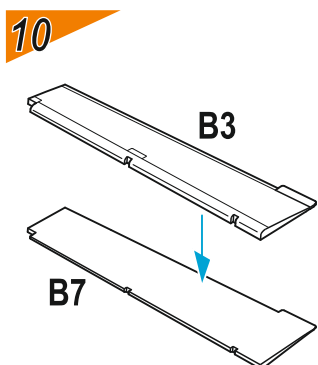
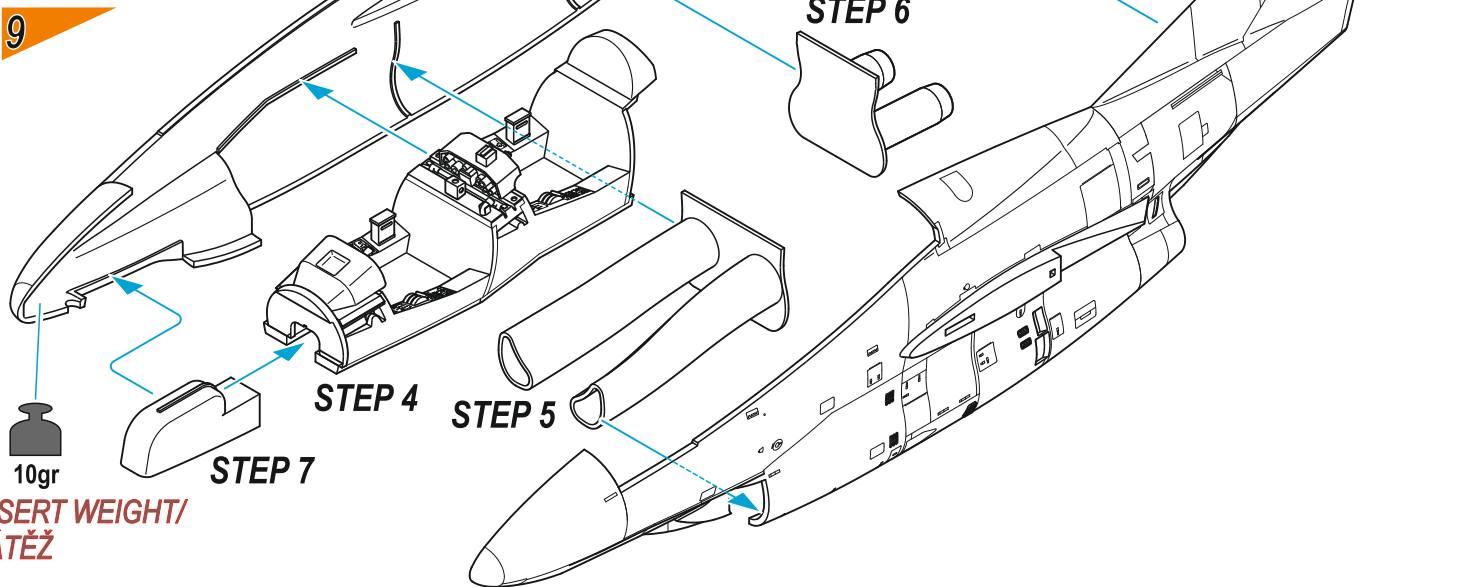
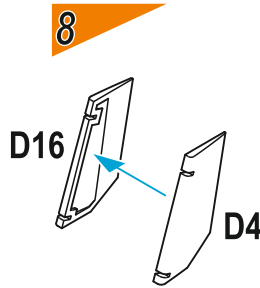
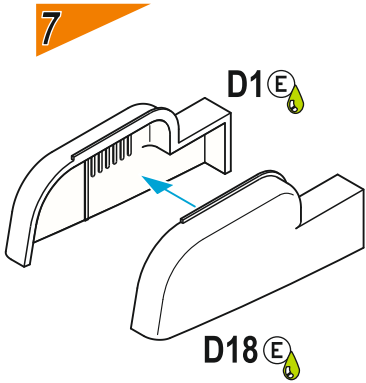
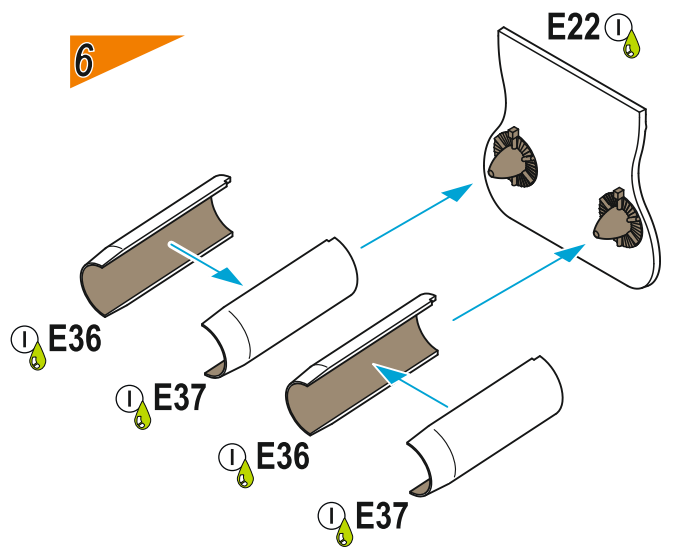
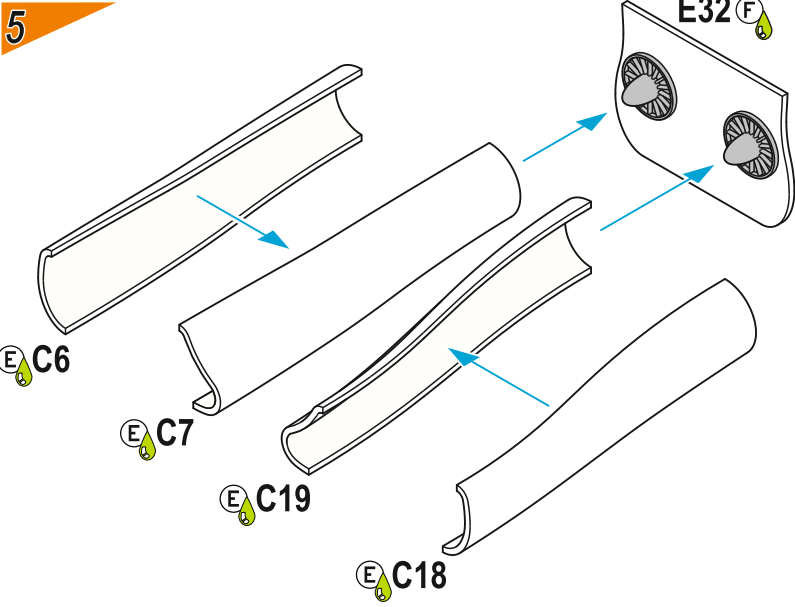

14

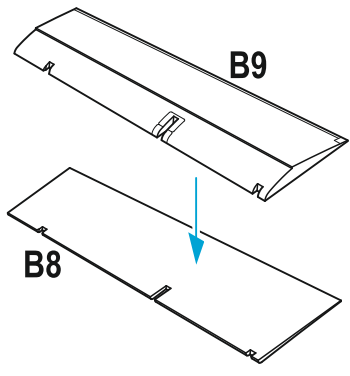

16

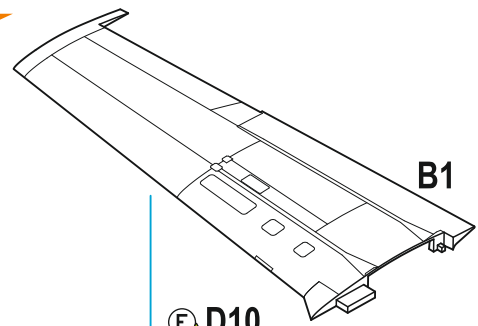

17

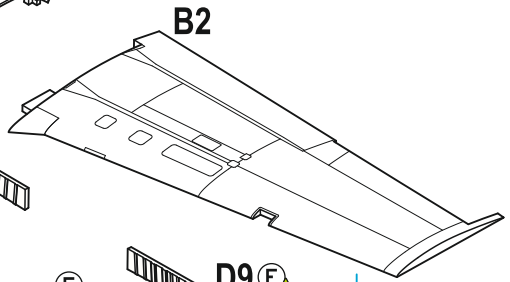

15

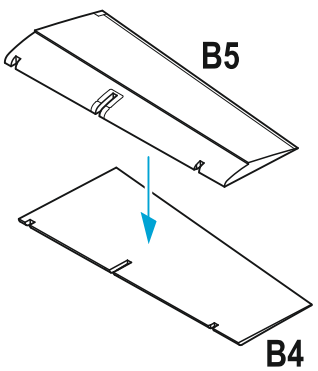

19

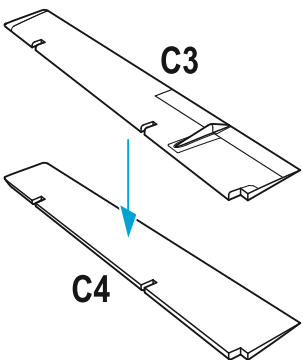

20

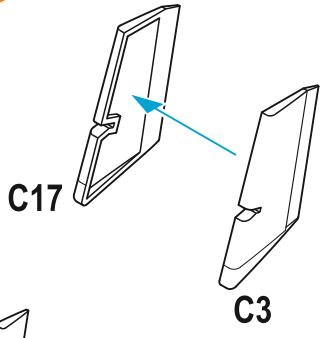

18

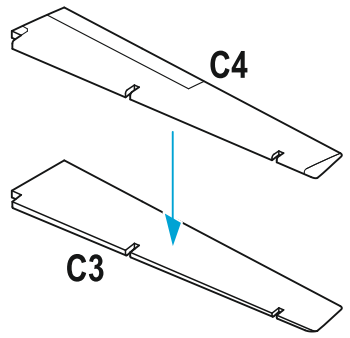

21

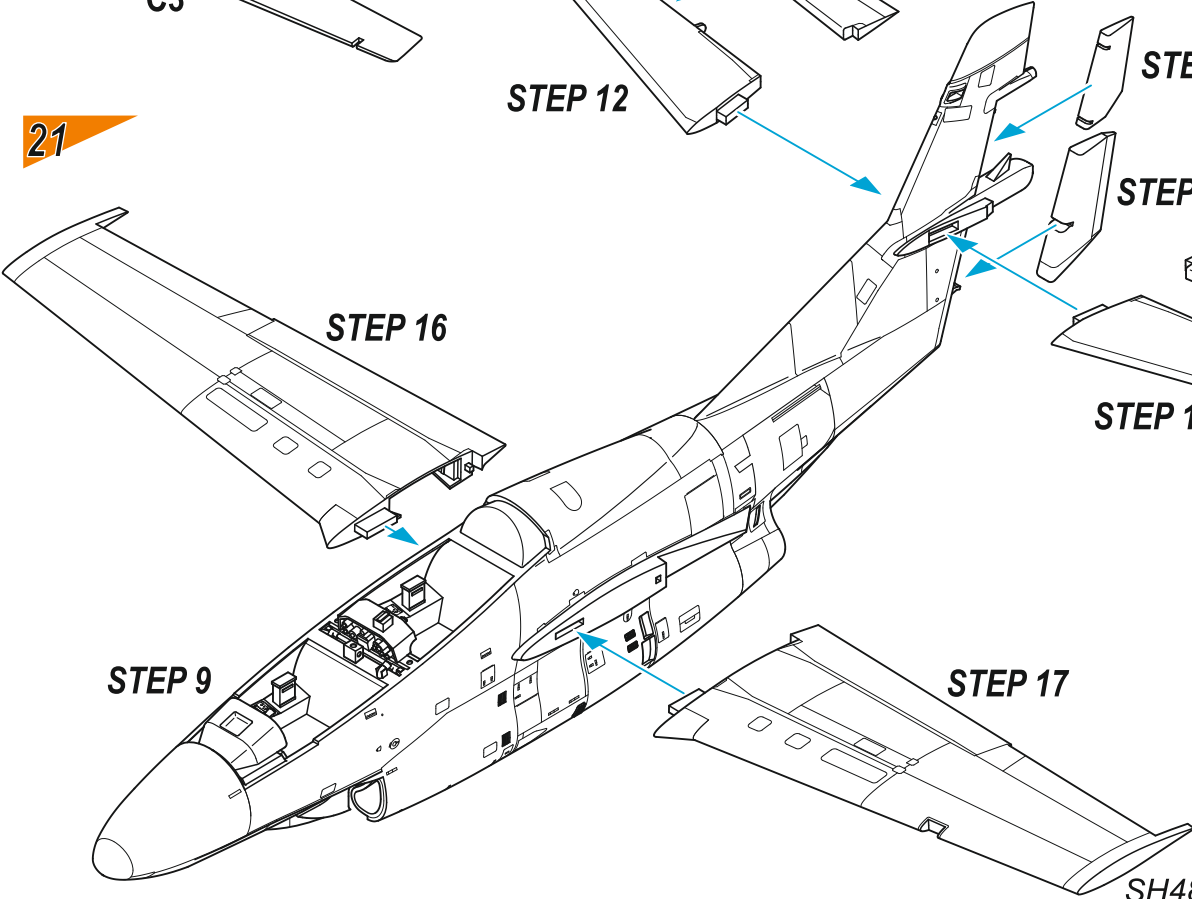
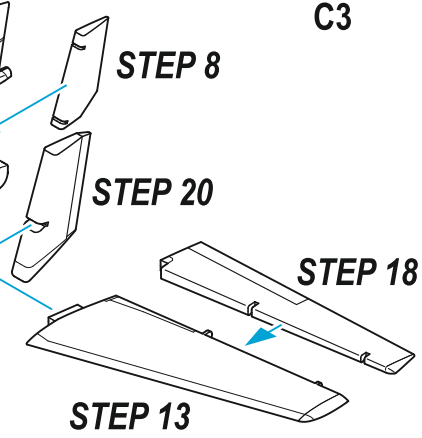
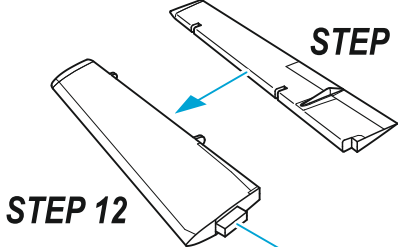
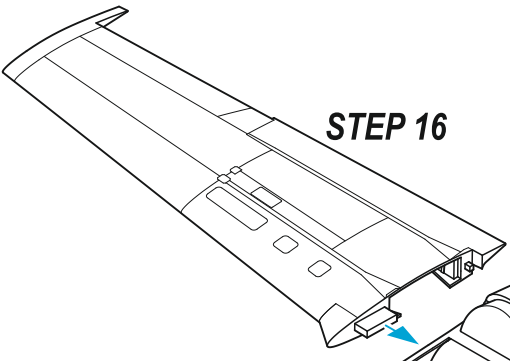

22

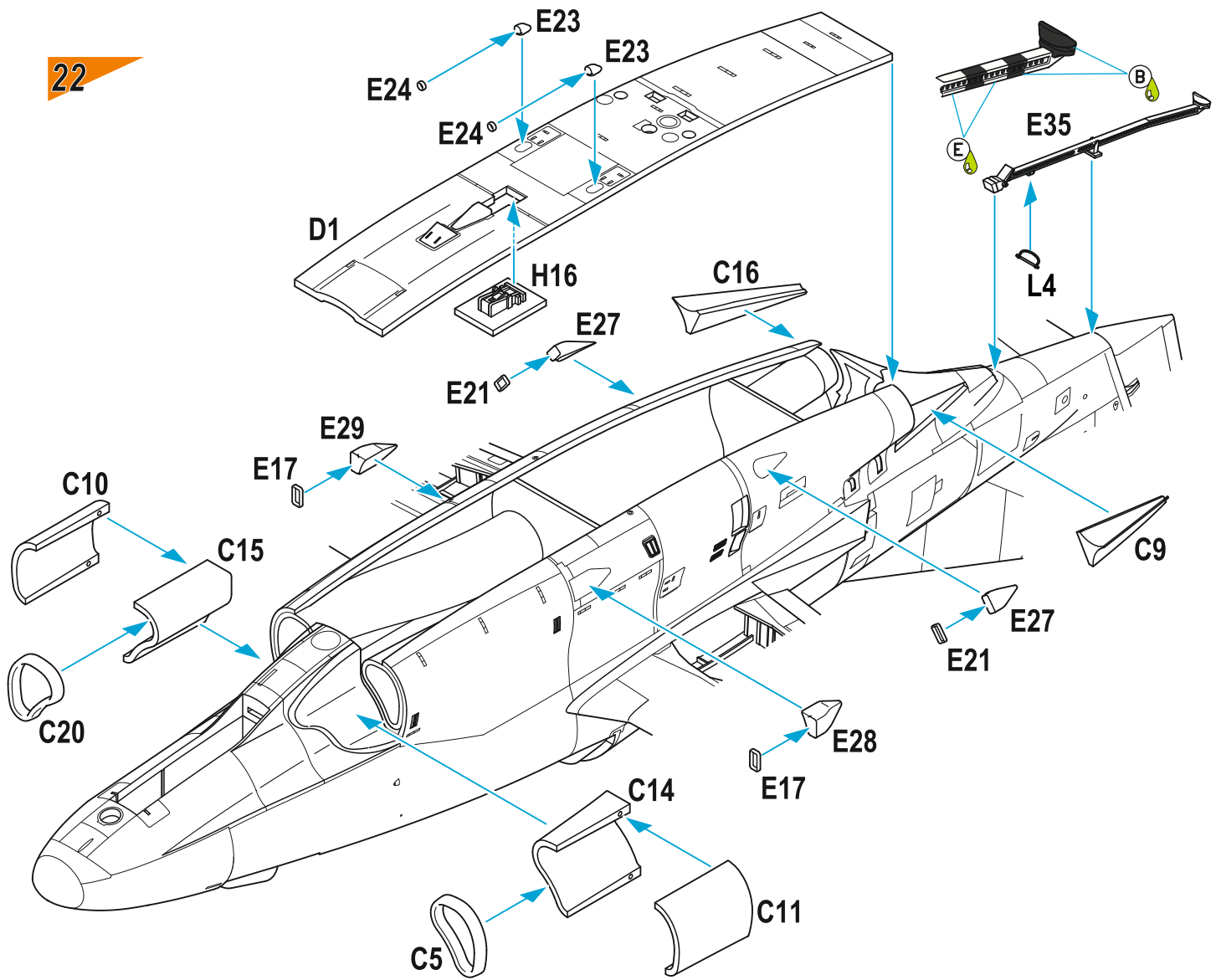

23

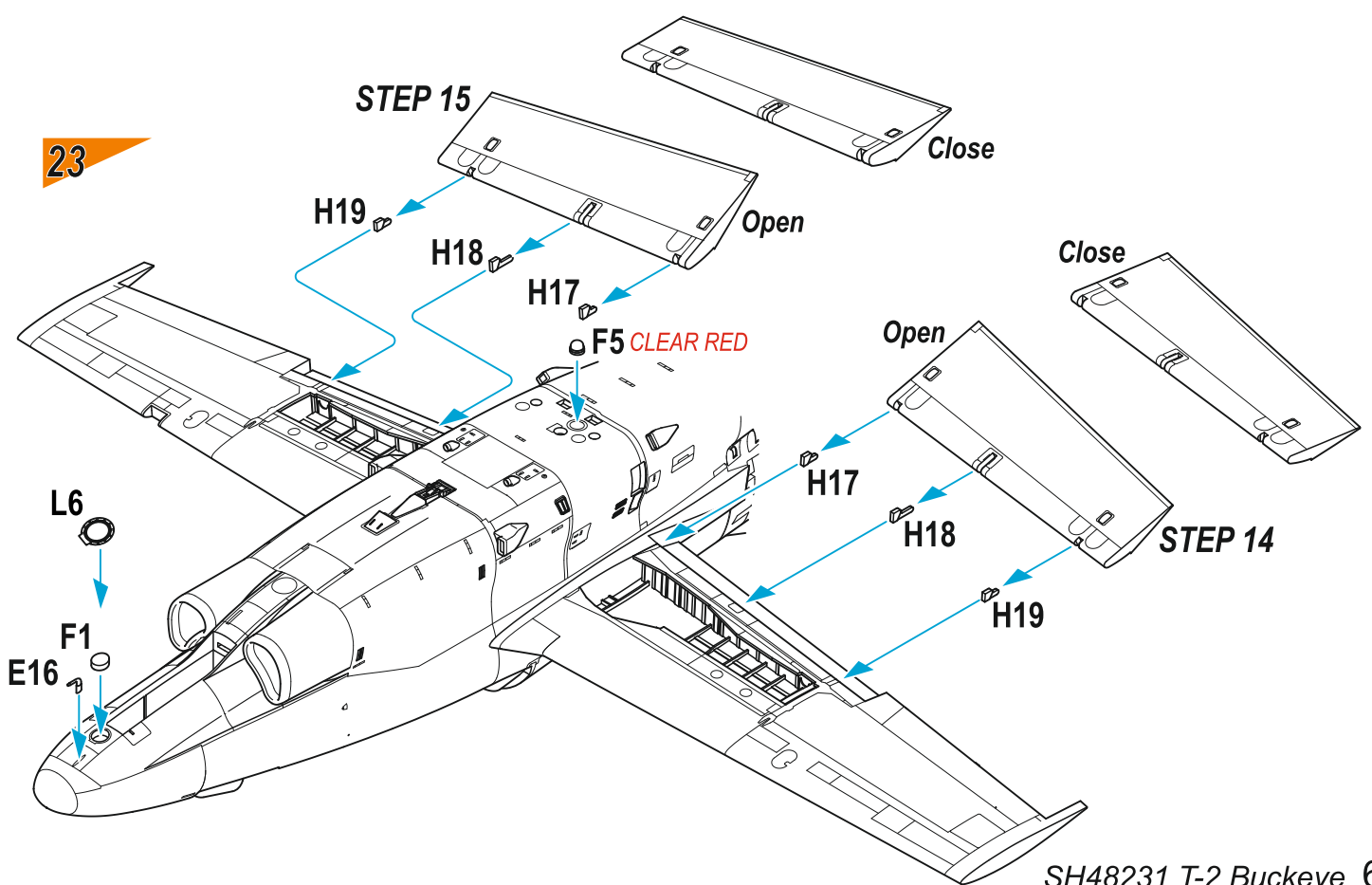

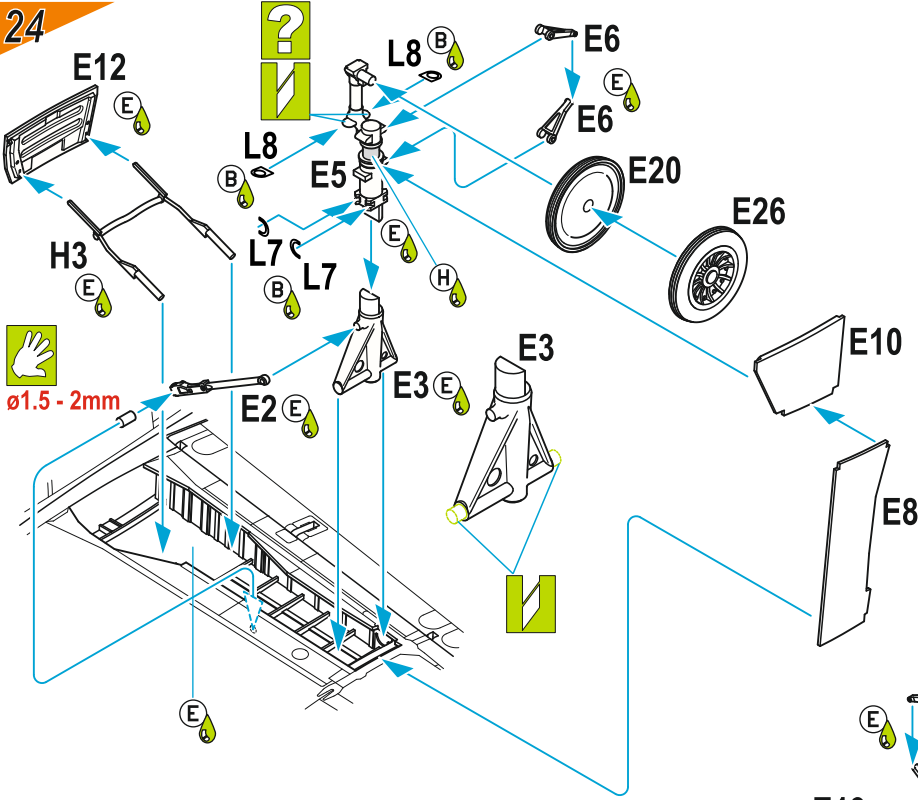

**25**

**COLOUR NOTES:**  
E19, E20 E26

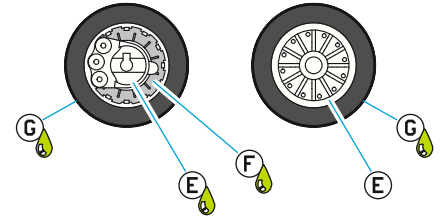

**27**

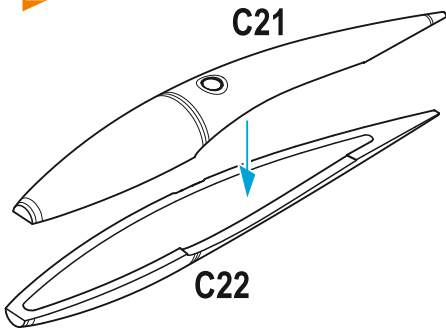

**26**

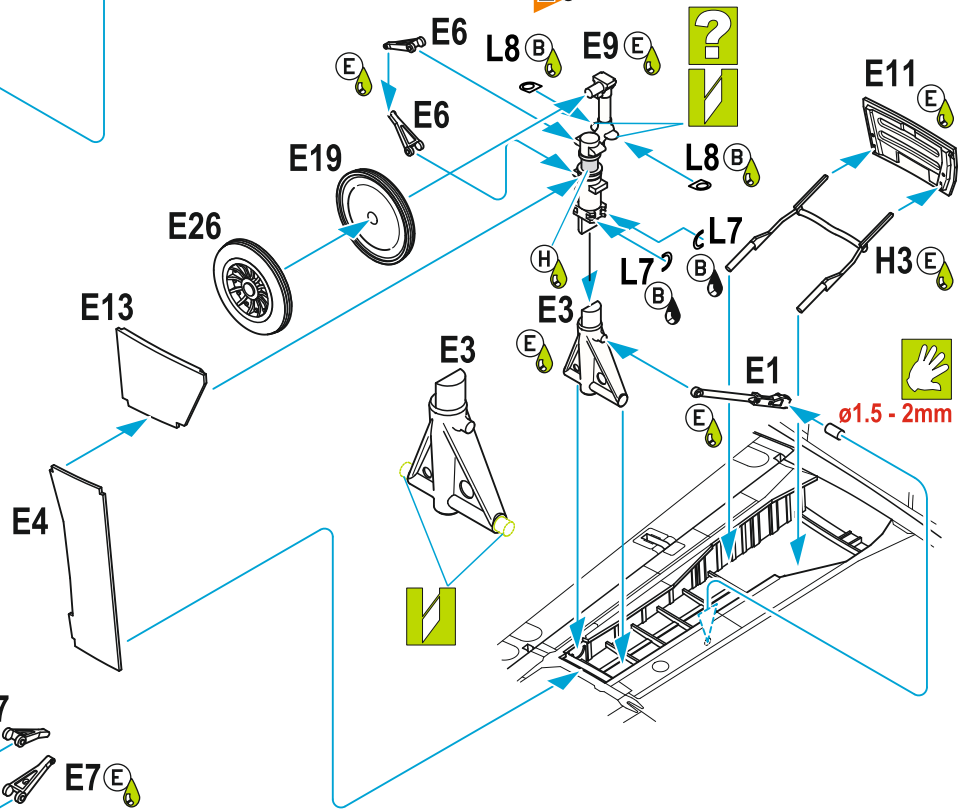

**28**

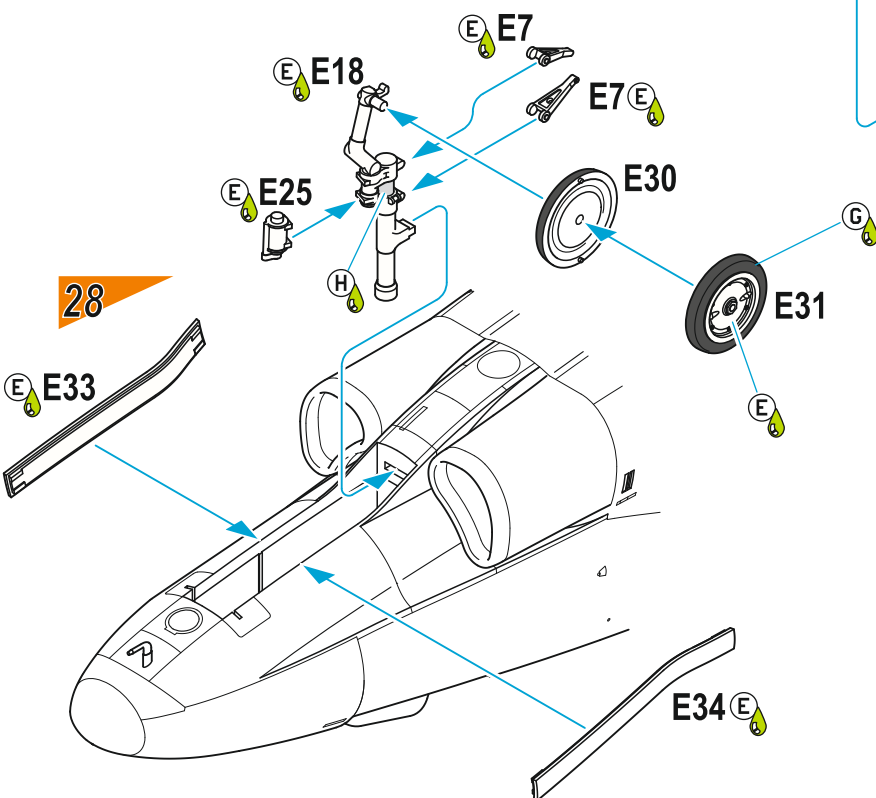

**29**

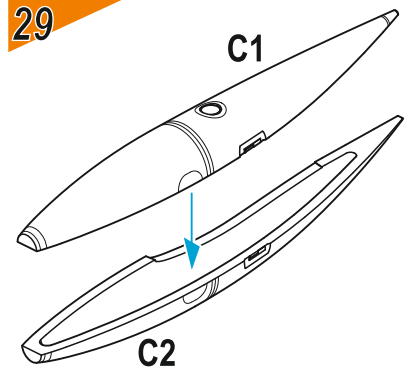

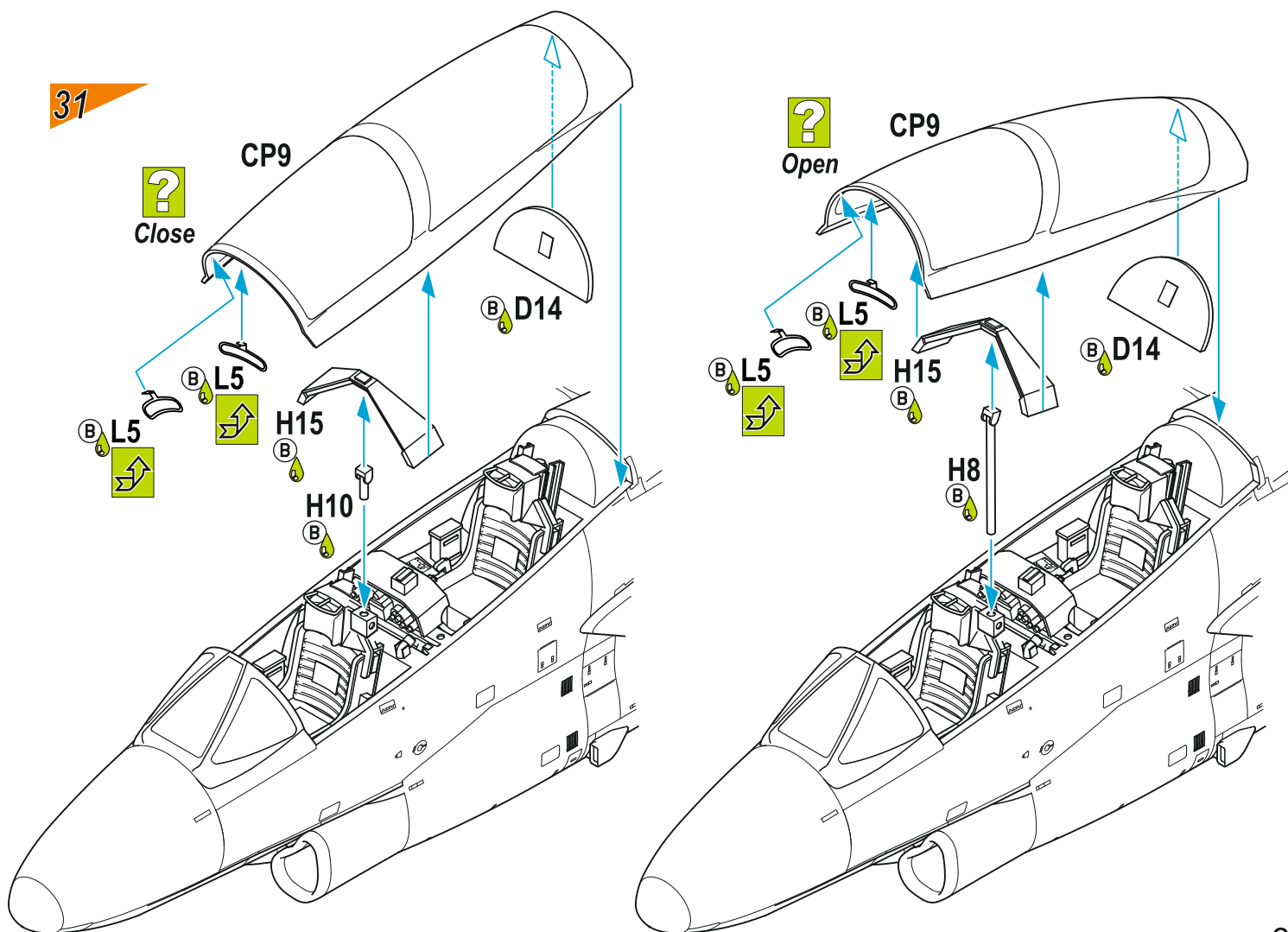
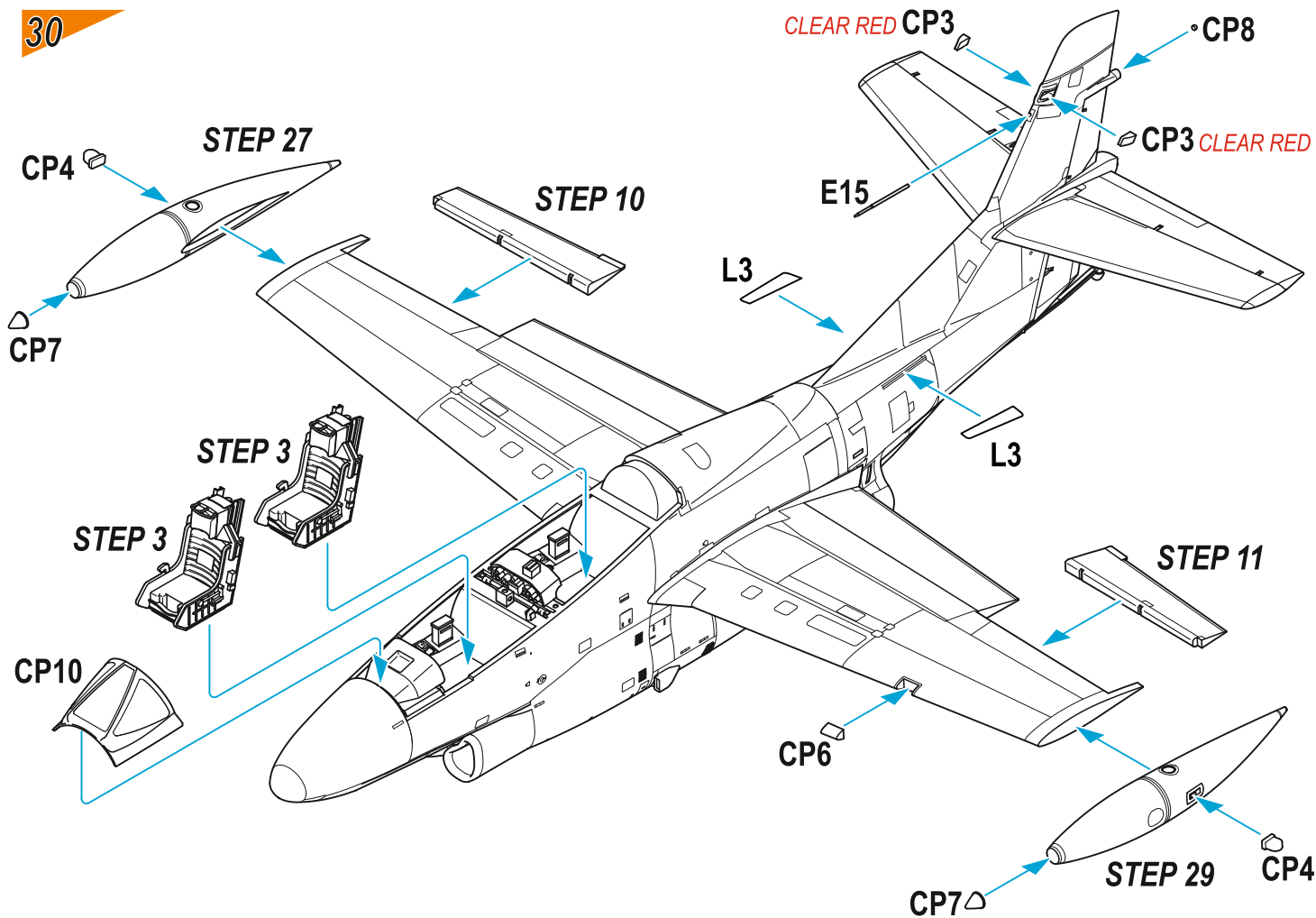





T-2C Buckeye, Bu.No. 155241, No.309, VT-23 'The Professionals', Naval Air Station Kingsville, Texas. V roce 1976, při příležitosti dvousetleté existence USA, dostaly letouny T-2C jednotky VT-23 výroční zbarvení s modrou přídí a svíslou ocasní plochou.

T-2C Buckeye, Bu.No. 155241, No.309, VT-23 'The Professionals', Naval Air Station Kingsville, Texas. In 1976 to mark the United States Bicentennial, the T-2C Buckeyes of VT-23 were painted blue on the nose section and the tailfin.

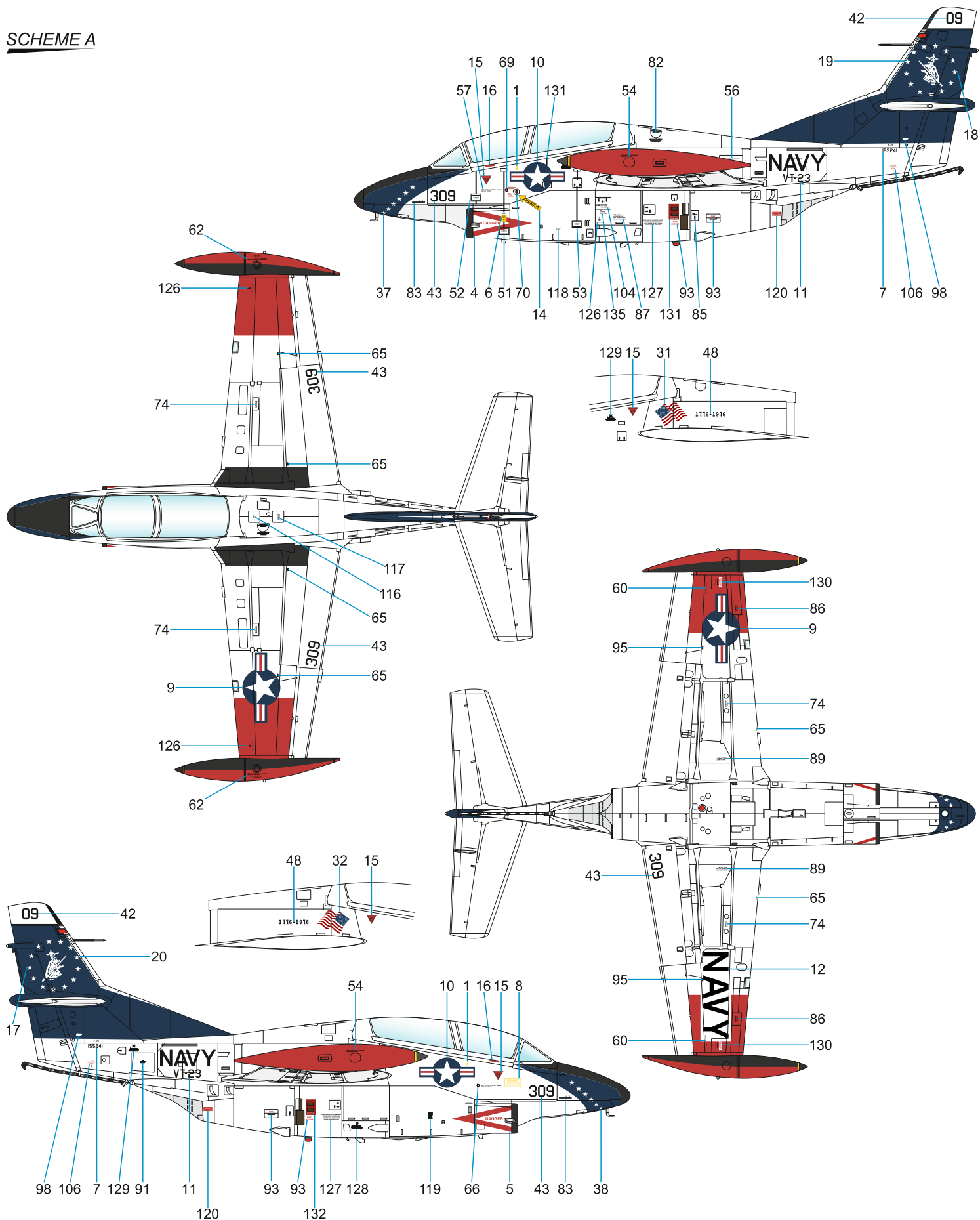
**SCHEME A**



- 

Matná černá  
Flat Black  
H12/ C33
- 

Tmávě modrá  
Dark Blue  
H328/ C328
- 

Červená  
Red  
H327/ C327
- 

Bílá  
White  
H21/ C1

T-2E Buckeye, Bu No. 160084, No.84, 363 MEA 'Danaos' (MEA - Mira Ekpedefsīs Aeros/ Ietecká cvičná perut'), 120 PEA (PEA - Pteriga Ekpedefseos Aeros/ Ietecké cvičné křídlo), základna Kalamata, řecké vojenské letectvo. Při příležitosti čtyřicetileté existence 363 MEA dostal tento letoun v roce 2012 výroční zbarvení.

T-2E Buckeye, Bu No. 160084, No.84, 363 MEA 'Danaos' (MEA - Mira Ekpedefsīs Aeros/ Air Training Squadron), 120 PEA (PEA - Pteriga Ekpedefseos Aeros/ Air Training Wing), Kalamata, Hellenic Air Force. For the 40th anniversary of the 363 MEA in 2021, this airframe received special colour scheme.

**SCHEME B**

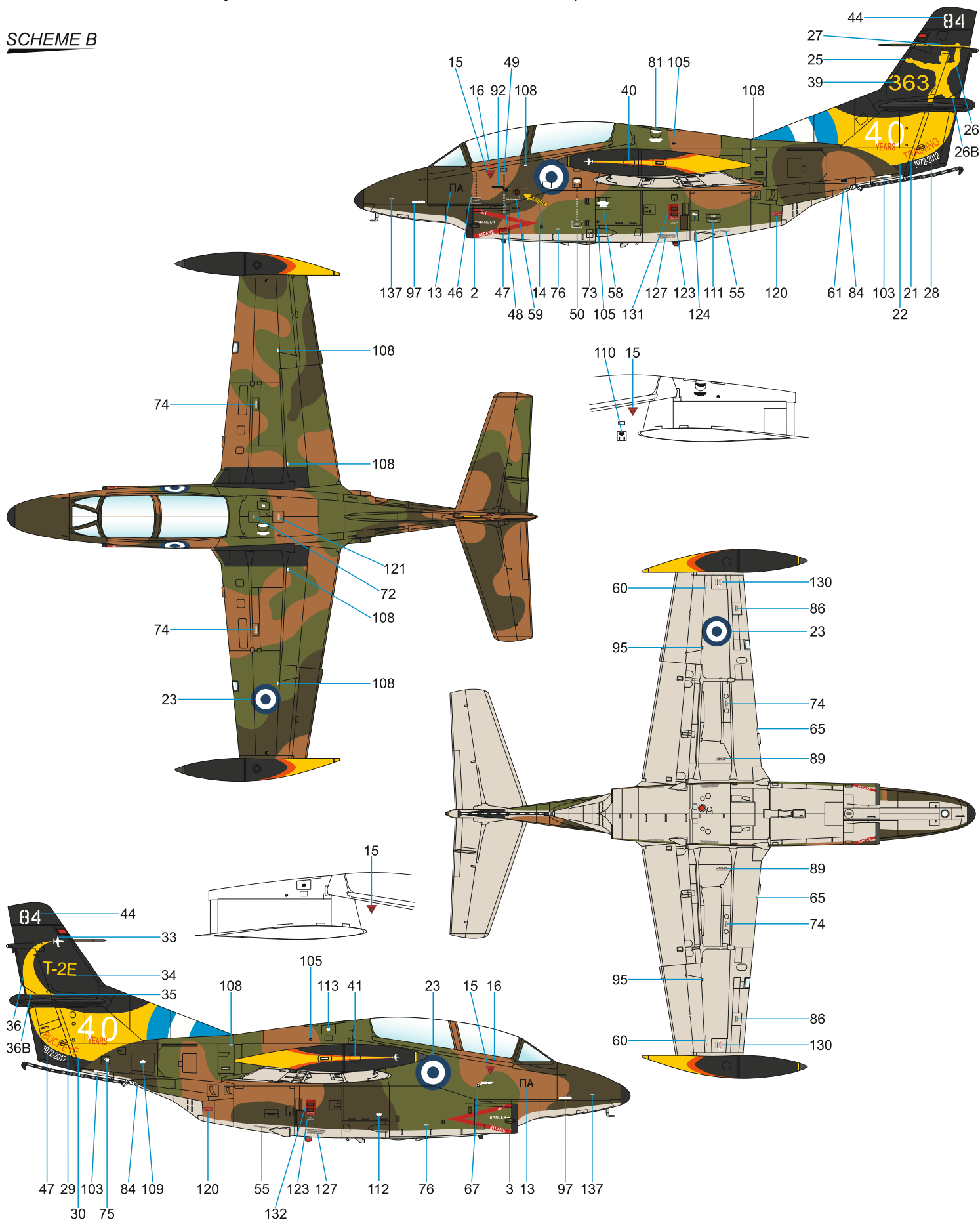

- 

Matná černá  
Flat Black  
H12/ C33
- 

Tmávě zelená  
Dark Green  
H309/ C309
- 

Středně zelená  
Medium Green  
H303/ C303
- 

Tříslivá  
Tan  
H310/ C310
- 

Světle šedá  
Light Grey  
H311/ C311

# ATTRACTIVE 1/48 SCALE MODELS & SETS

1 *special*  
48 **HOBBY**

SH 48209



**SAAB SK-37 Viggen 'Trainer'**

1 *special*  
48 **HOBBY**



**AJ-37 Viggen**  
'Strike Fighter'

SH 48216

## CMK resin sets for Viggen

129-4310



Bofors m/70  
Rocket Pod (2 pcs.)

129-Q48219

SAAB 37 Viggen  
Ejection Seat



129-Q48220

AAB 37 Viggen  
Air Brakes Set



129-  
Q48221

SAAB 37  
Viggen Wheels



129-Q48222

SAAB 37 Viggen  
Thrust Reverser



129-4385

SAAB 37 Viggen  
Control Surfaces



129-F48351



SAAB 37  
Viggen Pilot  
Climbing Ladder  
into Cockpit

1 *Special*  
48 **HOBBY**



*STEP 2*  
**AH-1Q/S Cobra 'US & Turkish ARMY Service'**

SH 48232

1 *Special*  
48 **HOBBY**



**AH-1G  
COBRA**  
'Over Vietnam  
with M-35  
Gun System'

Hi-Tech kit



CMK resin conversion sets



129-4268

MD-500E/OH-6DA  
Conversion set for Hasegawa kit



129-4275

MH-6E/J/M Little Bird  
Conversion set for Academy kit



129-4276

AH-6F/J Attack version  
Conversion set for Academy kit

*Special*  
**HOBBY**

facebook.com/specialhobby| [WWW.SPECIALHOBBY.EU](http://WWW.SPECIALHOBBY.EU) [WWW.CMKKITS.COM](http://WWW.CMKKITS.COM)

