



DB-8A/3N 'Outnumbered and Fearless'

CZ Letoun Northrop A-17 byl původně navržený jako útočný letoun pro jednotky USAAC (americká armáda). Holandská vláda objednala 18 kusů exportní verze tohoto letounu pro holandské letectvo, které pak byly dodány v době od srpna do listopadu 1939.

Továrna Northrop byla však 31. srpna 1939 převzata společností Douglas Aircraft Co. Inc., a stala se její dceřinou firmou. Byla pak známa jako El Segundo Division společnosti Douglas. Takže ačkoliv letouny Northrop A-17 a A-17A dodané jednotkám Army Air Corps si ponechaly původní název Northrop, exportní verze byly označeny jako Douglas DB-8A, pokud byla objednávka předložena po datu převzetí továrny Northrop.

Letouny dodané holandskému letectvu byly označeny jako DB-8A-3N a byly po dodání přiděleny 5. stíhací peruti 2. leteckého pluku holandského královského letectva se základnou v Ypenburgu.

10. května 1940 německá armáda zahájila západní ofenzivu a překročila hranice neutrálního Holandska. Dvanáct letounů DB-8A-3N bylo v té době operačně nasazeno u jednotky na základně v Ypenburgu, pět strojů bylo drženo jako rezerva na základně Ockenburg (osmnáctý letoun byl ztracen při předchozí letecké nehodě při výcviku). Ze 12 strojů na základně Ypenburg se podařilo při zahájení německého útoku odstartovat jednácti strojům, jeden letoun DB-8A-3N byl zničen na zemi letounem německé Luftwaffe Messerschmitt Bf 110.

Z jedenácti strojů, kterým se podařilo vzlétnout bylo útočníky sestřeleno sedm letounů, čtyřem letounům DB-8A-3N se podařilo sestřelit několik německých transportních letounů Ju 52.

Po návratu na základnu byly pak tyto čtyři přeživší stroje zničeny na zemi při dalším útoku Luftwaffe.

Pět rezervních letounů DB-8A-3N ze základny v Ockenburgu bylo zabaveno postupujícími německými jednotkami, všechny letouny byly nepoškozené. Jeden z těchto letounů byl v roce 1941 vystaven v Berlíně, později však byl zničen při spojeneckých náletech.

Letoun DB-8A-3N byl poháněn vzduchem chlazeným dvouhvězdicovým motorem P&W R-1830-S3CG Twin Wasp. Výzbroj tvořily čtyři kulomety v křídlech ráže 0.30 palce, plus pohyblivý kulomet ráže 0.30 palce ovládaný zadním střelcem. Letoun byl schopen nést 20 bomb (po 15 kg) ve vnitřní trupové pumovnici, a čtyři bomby o váze 50 kg na externích závěsnících. Maximální pumová zátěž byla 600 kg.

Technické údaje: Rozpětí 14,55 m. Délka 9,80 m. Max. rychlost 418 km/hod. Dolet 1464 km. Operační dostup 9022m

EN Originally designed as the Northrop A-17 ground attack aircraft for the USAAC, 18 export version aircraft were ordered by the Netherlands Government and delivered between August and November 1939.

However, on 31 August 1939, the Northrop Corporation was taken over and became a subsidiary of the Douglas Aircraft Co. Inc., thereafter known as the El Segundo Division of the Douglas Company. Thus, although the A-17 and A-17A attack aircraft of the Army Air Corps retained the Northrop name, export versions were designated Douglas DB-8A when contracts were placed subsequent to this date, so explaining the difference in name between the US and Dutch variants.

The Douglas DB-8A-3Ns were allocated to 5 Fighter Squadron of 2 Air Regiment of the Royal Netherlands Air Force based at Ypenburg.

On May 10, 1940, German forces began their Western offensive crossing the border into the neutral Netherlands. Twelve DB-8A-3N aircraft were on active duty at Ypenburg and five held in reserve at Ockenburg (the 18th aircraft had been previously lost in a training accident).

Of the twelve Ypenburg aircraft, eleven managed to get airborne, but one was destroyed on the ground by the attacking Luftwaffe Messerschmitt Bf 110s. Of these eleven, seven were shot down by the attackers but the remaining four managed to account for some Junkers Ju 52 transporters. However, these four survivors of the first raid were subsequently destroyed on the ground by another German raid.

The five reserve DB-8A-3Ns at Ockenburg were captured intact by the Germans. In 1941 one of these aircraft was exhibited in Berlin. However, this plane was later destroyed during an Allied bombing raid.

The Douglas DB-8A-3N was powered by a Pratt & Whitney R-1830-S3CG Twin Wasp air-cooled radial engine. Armament was four wing-mounted 0.30-inch machine guns, plus one flexible 0.30-inch machine gun operated by the rear gunner. Normal bomb load included 20 internally-carried 30lb bombs and four external 100lb bombs. The maximum bomb load was 1200 pounds.

Technical specifications: Span 47 ft 9 in (14,55 m). Length 32 ft 5 in (9,80 m). Maximum speed was 260mph (418km/h).

Range 910 miles (1464 km). Service ceiling 29,600 ft (9022m)

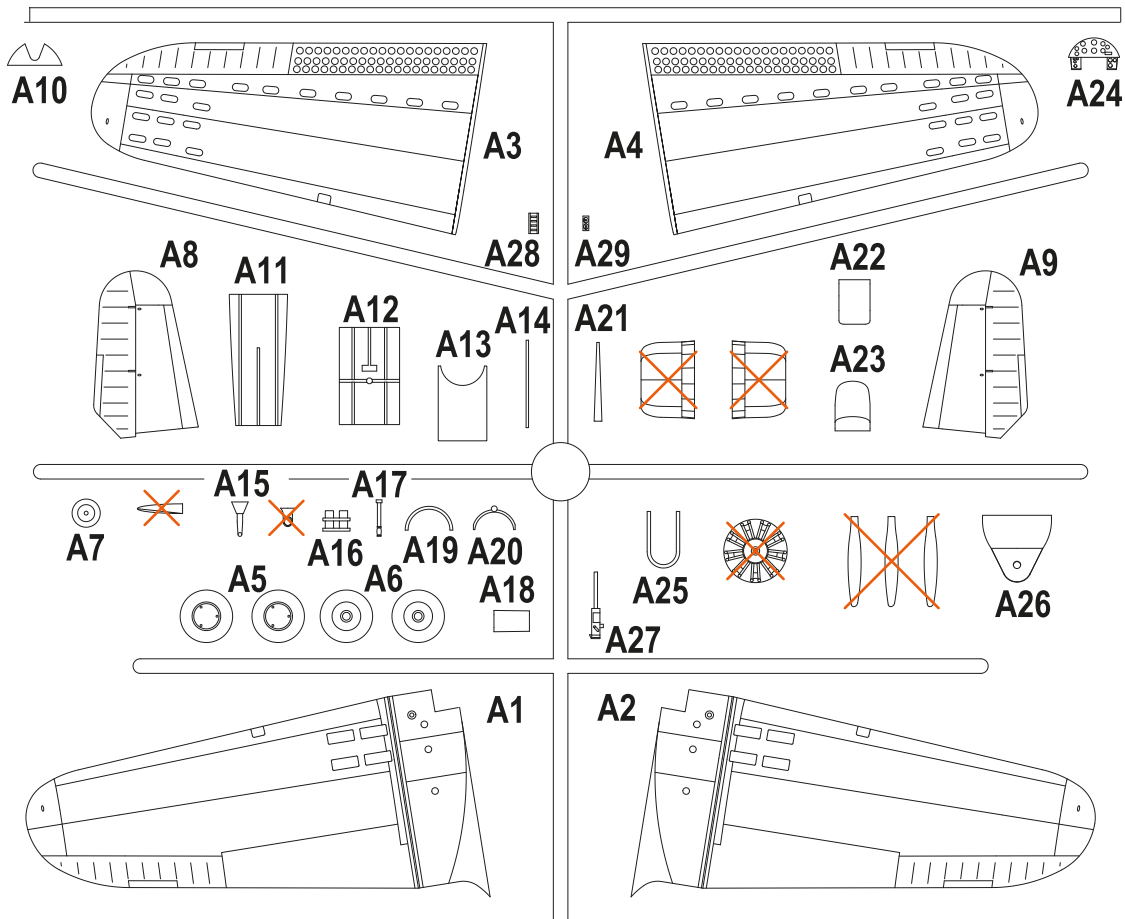

CLEAR PARTS (CP)

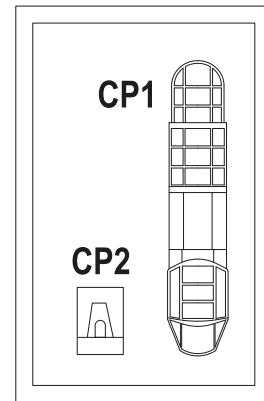
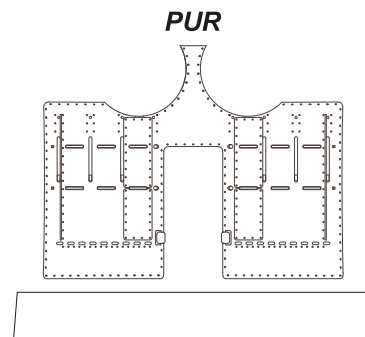
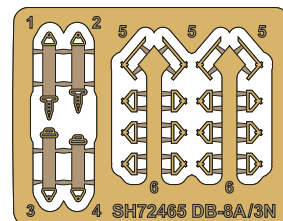

PHOTO-ETCHED PARTS (PP)



X *Tento díl nepoužít*
Do not use this part

SYMBOLS

? **MOŽNOST VOLBY**
OPTIONAL
NACH BELIEBEN
OPTION

🔴 **POUŽÍT KYANOAKRYLÁTOVÉ LEPIDLO**
INSTANT CYANOACRYLATE GLUE
ZYANOAKRYLÁTKLEBER
COLLE CYANOACRYLAT

↶ **OHNOUT**
BEND
BIEGEN
COURBER

✋ **ZHOTOVIT NOVÉ**
SCRATCH BUILD
FERTIGSTELLEN
ACHEVER



✂ **ŘEZAT/VRTAT**
CUT OFF/DRILL
ENTFERNEN
DETACHER

GSI **A**
colour code

🎨 **NATRÍT**
COLOUR
FARBEN
PEINDRE

STEP 1

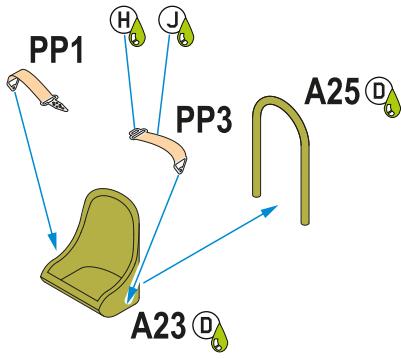

STEP 2

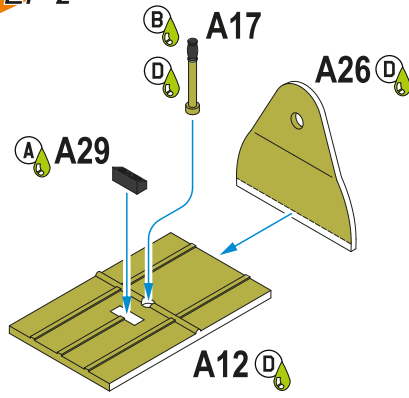

STEP 3

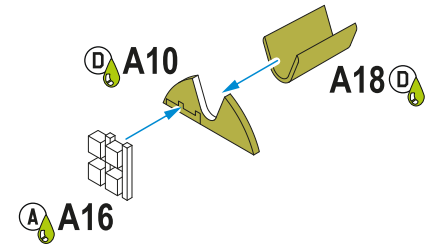

STEP 4

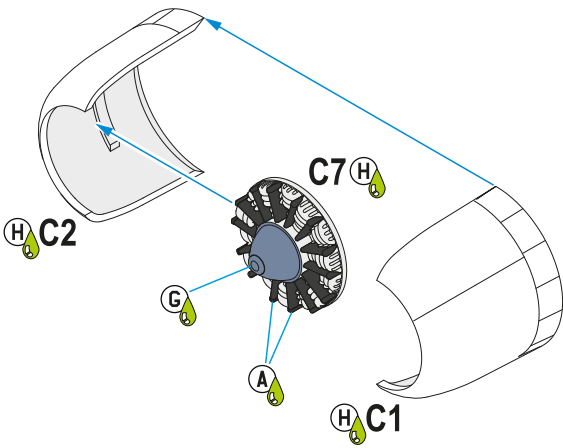

STEP 5

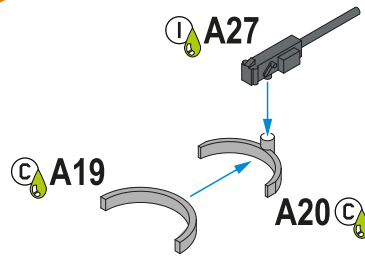

STEP 6

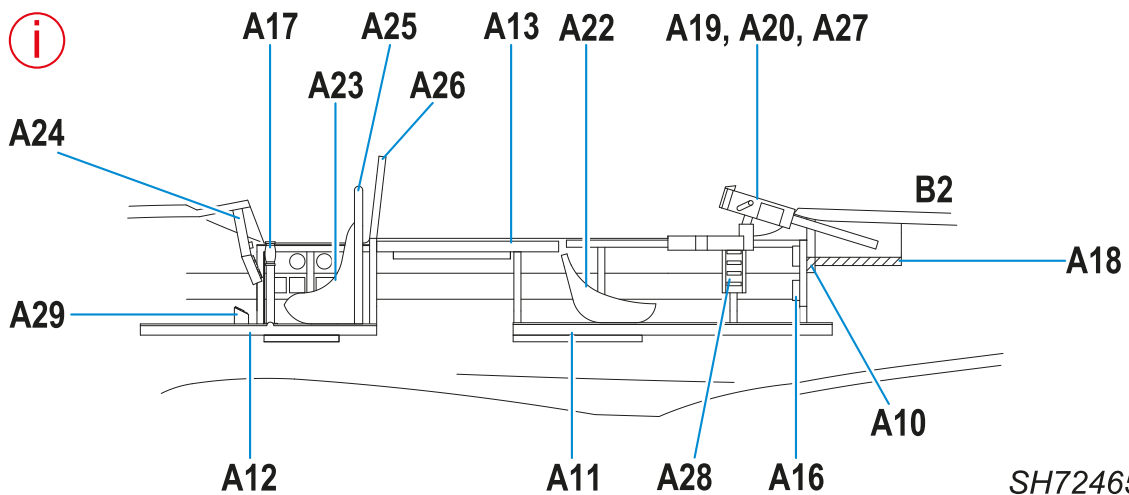
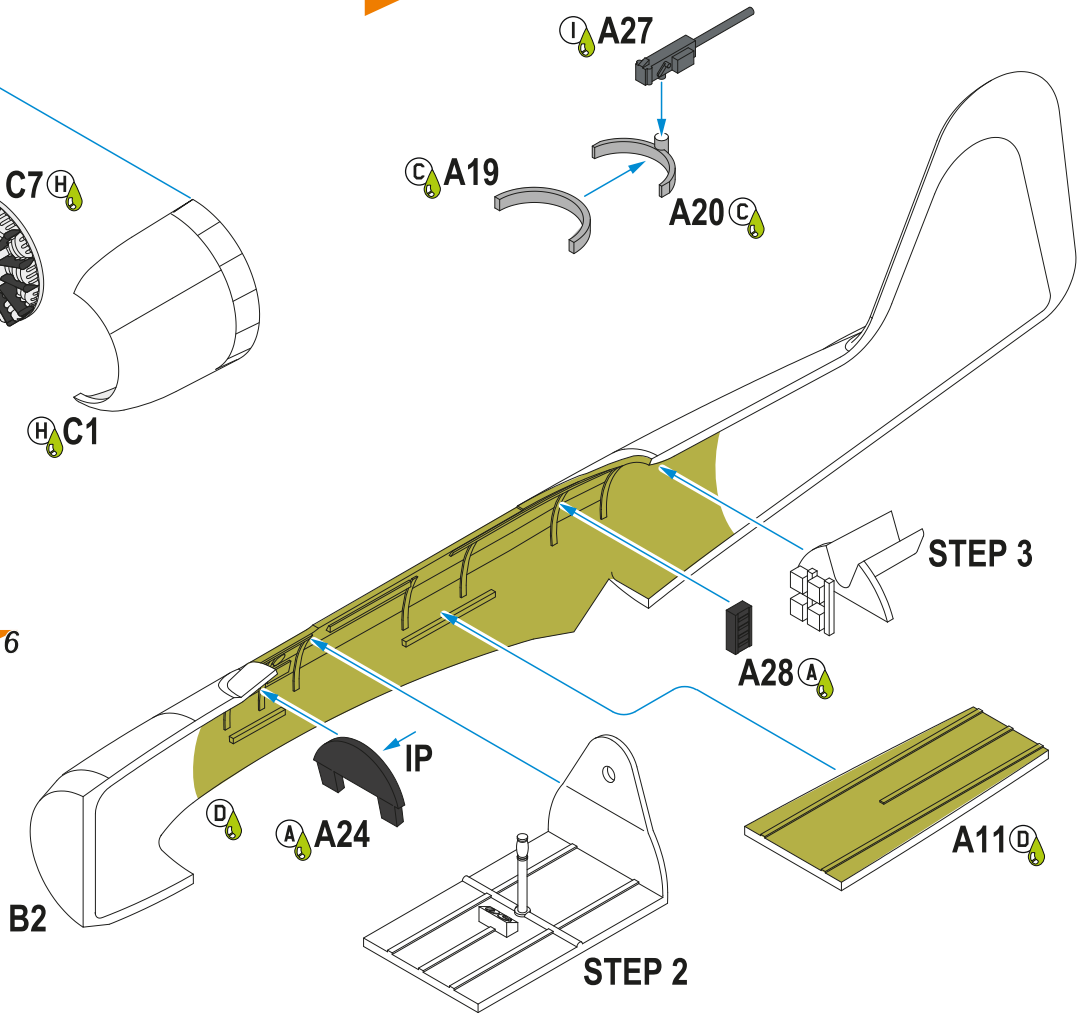

STEP 7

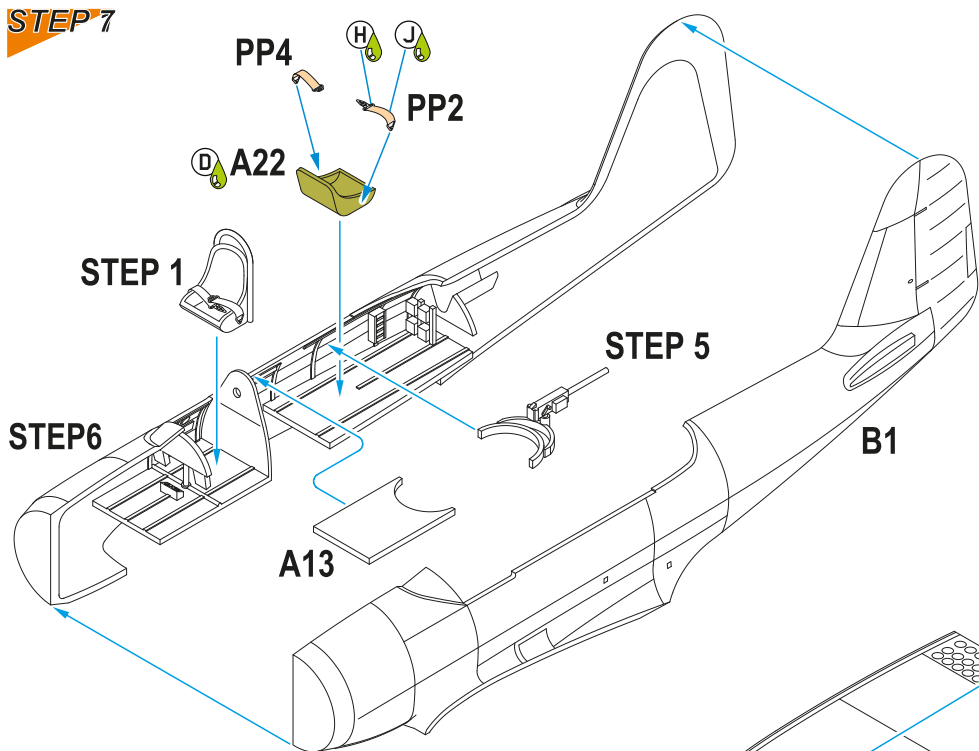

STEP 8

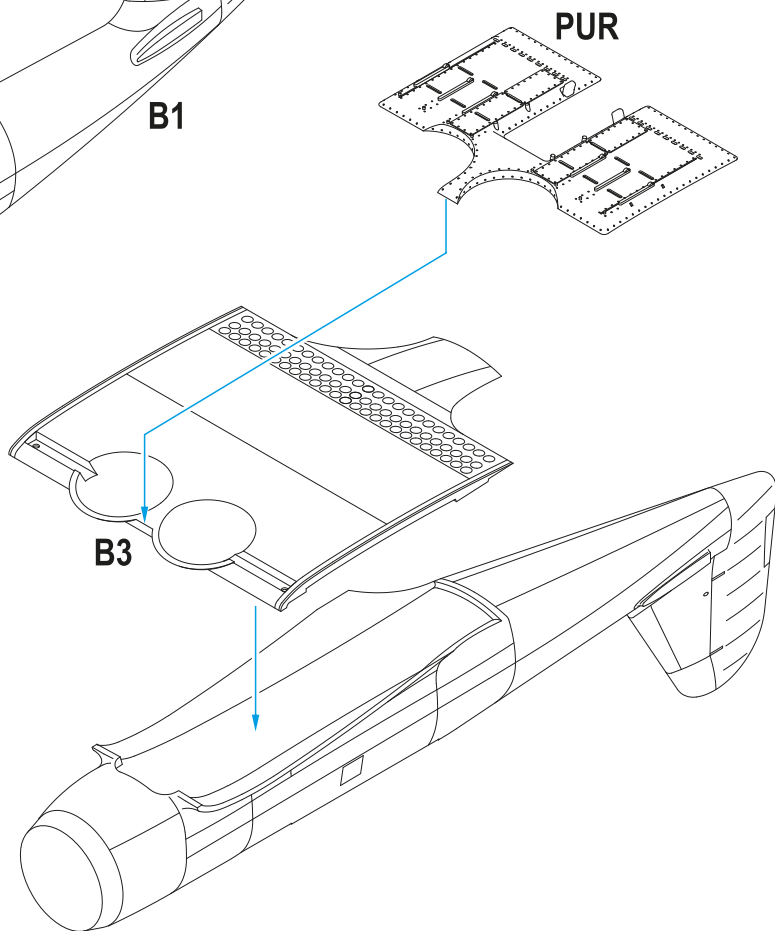

STEP 9

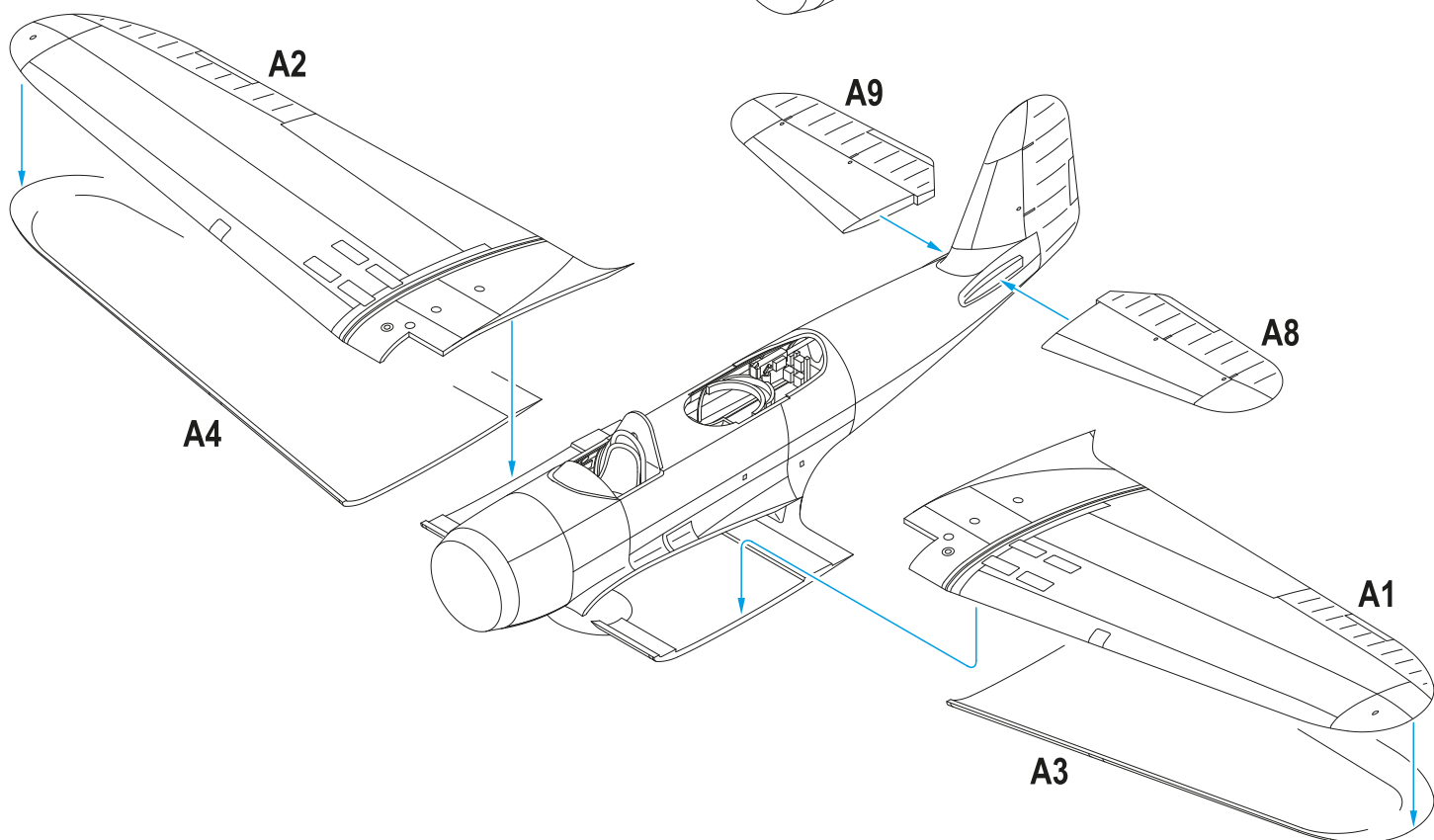

STEP 10

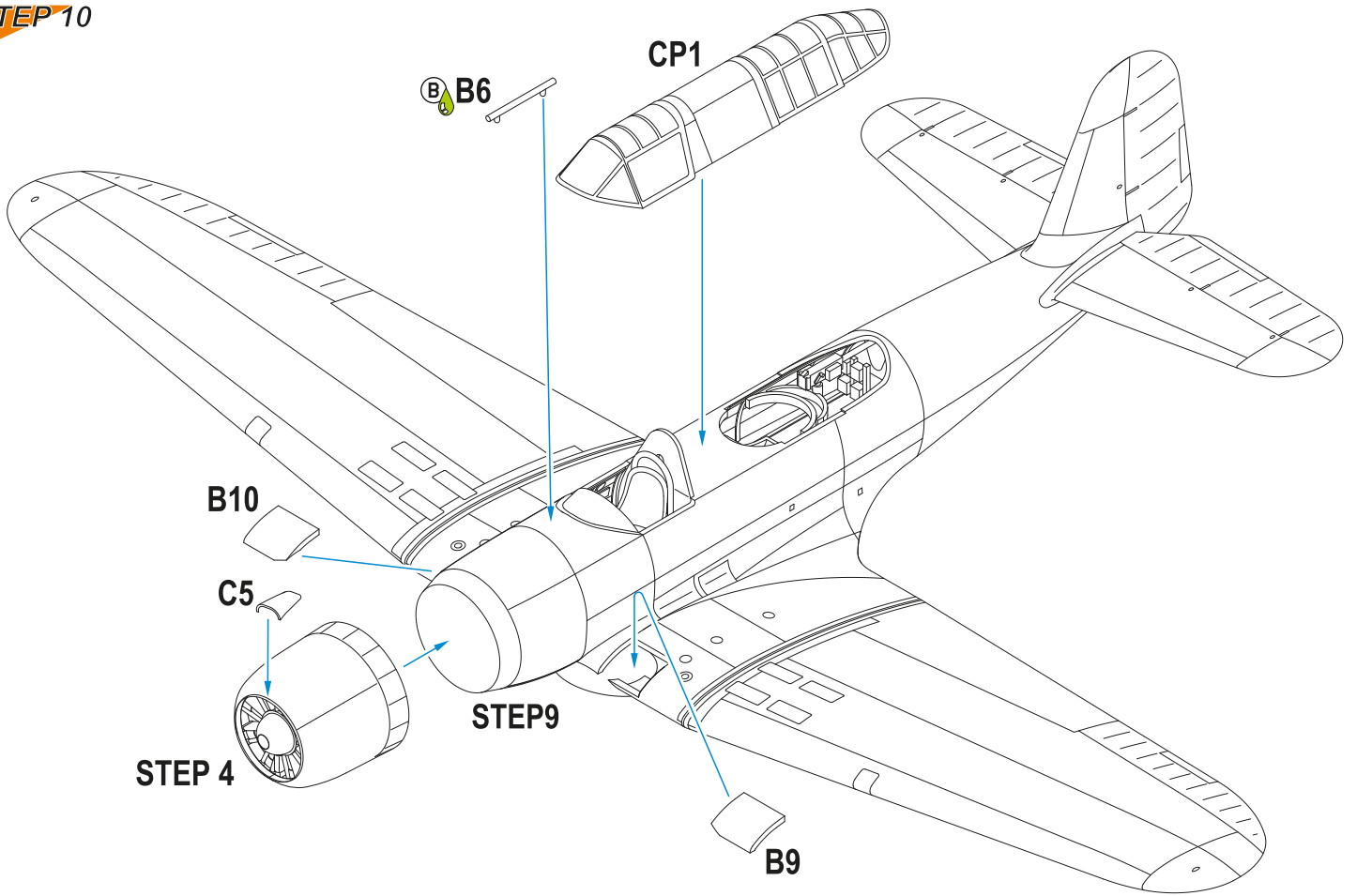

STEP 11

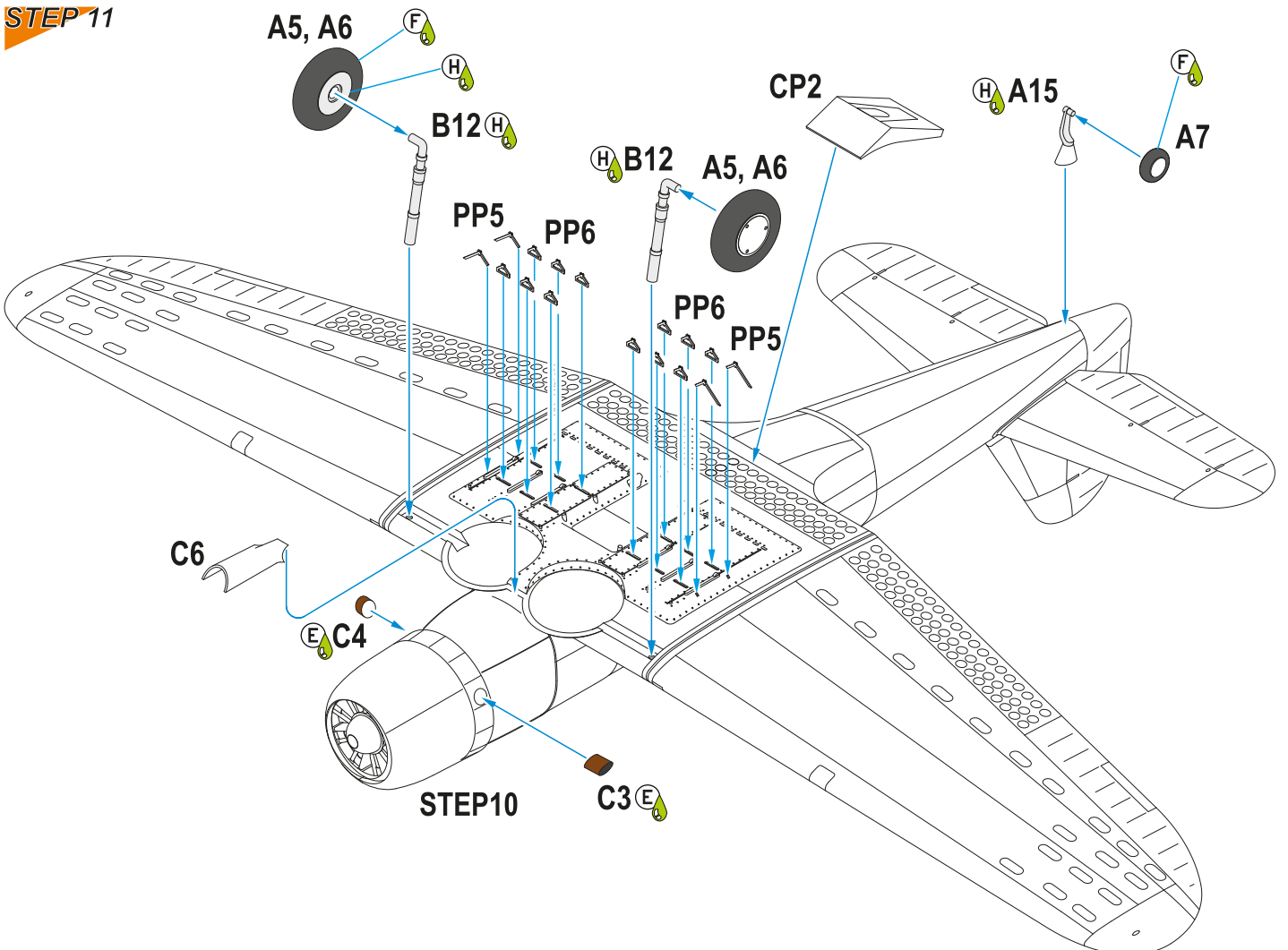

STEP 12

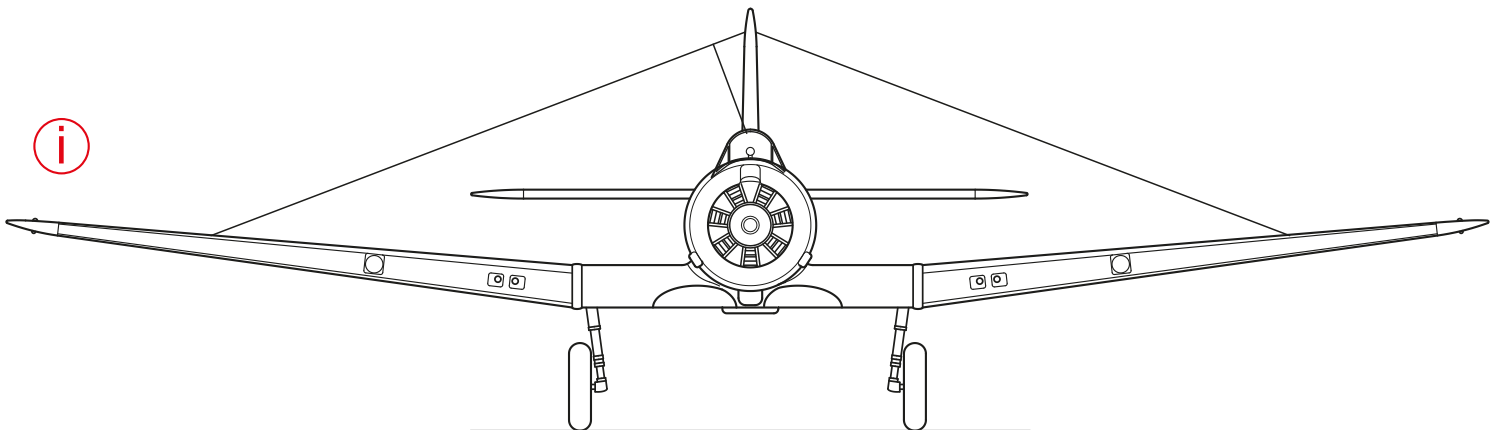
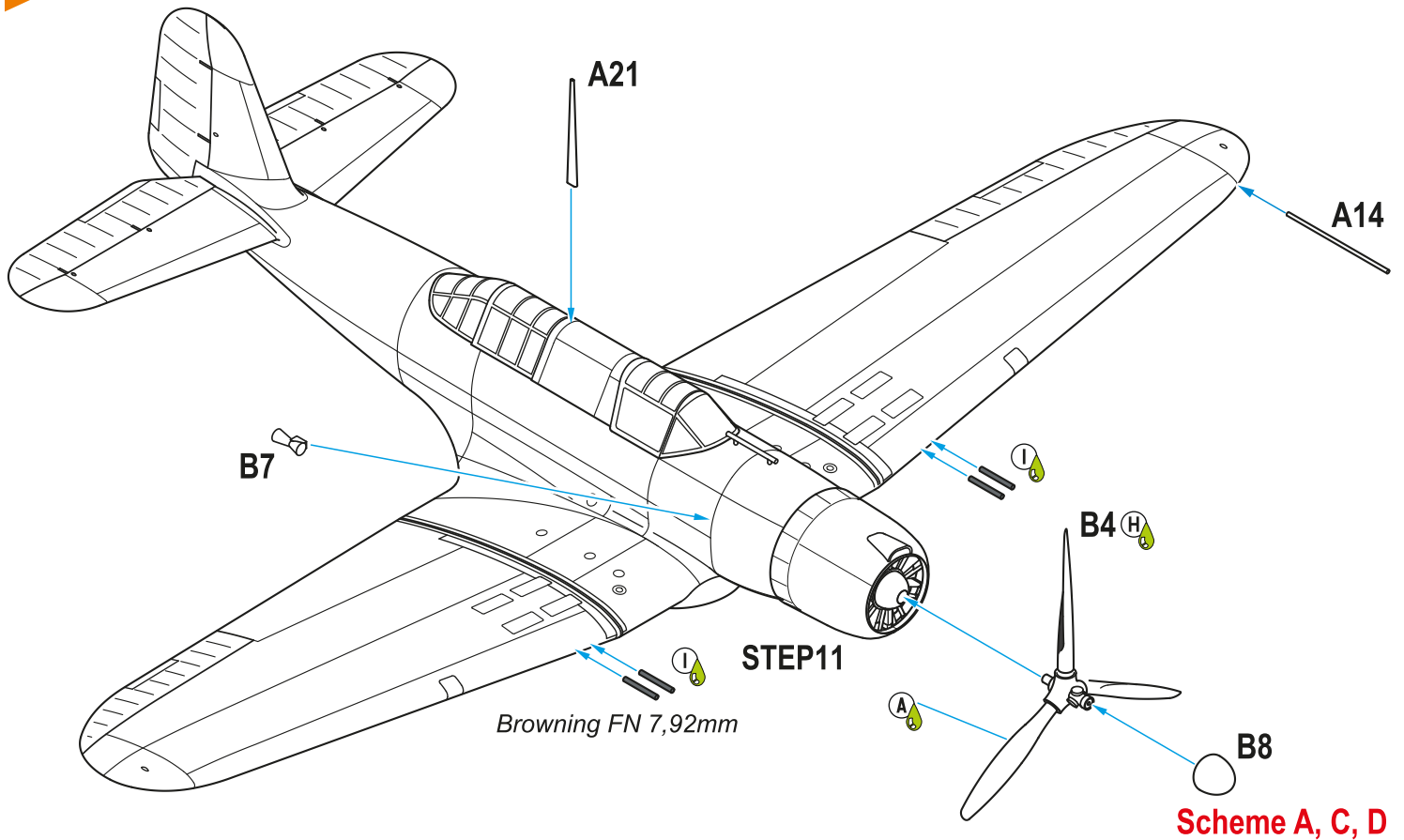

Barvy GUNZE / GUNZE Colour No.

A Černá lesklá / Gloss Black	H2 / C2	F Černá pneu / Tire Black	H77 / C137
B Černá matná / Matt Black	H12 / C33	G Šedá / Grey	H53 / C13
C Ocel / Steel	H18 / C28	H Hliníková / Aluminium	H8 / C8
D Interiérová zelená / Interior Green	C351	I Dělovina / Gunmetal	H28 / C78
E Opálený kov / Burnt Iron	H76 / C61	J Barva plátna / Tan	H27 / C44

H1020 Razor Saw Profi Set



A new type handle for our razor saws. Also contains H1018 and H1019 spare saws.

H1018
Triangle Razor Saw (1pc)



H1019
Multi-Shift Razor Saw (1pc)



Douglas DB-8A/3N, no. 390, (c/n 540), 3-V-2 Luchtvaart Regiment, Militaire Luchtvaart (holandské vojenské letectvo), 1940. Ač byly DB-8A/3N bombardovací letouny, holandské letectvo je používalo jako dvoumístné stíhačky. Tomu odpovídalo jejich nasazení a bohužel i jeho výsledky. 10. května 1940 s tímto letounem osádka pilot Sgt.vl. J.J de Bruin a pozorovatel elt. wnr. H.F.H. van Boekhout zaútočila na formaci Ju-52 a jeden z nich pravděpodobně sestřelila. Odvetnému útoku Bf 110 se letoun vyhnul, ale byl zasažen protivzdušnou obranou a nouzově přistál na louce, kde farář dojíl krávy. Osádka si půjčila farmářův automobil a odjela do Delftu. Tam byla zajata vlastními vojáky, ale ze zajetí je vysvobodila pilotova teta. Ta žila v Delftu a náhodou střetla eskortu se 'zajatci' a svého synovce poznala.

Douglas DB-8A/3N, no. 390, (c/n 540), 3-V-2 Luchtvaart Regiment, Militaire Luchtvaart (military aviation in Dutch), 1940. Although the type had been designed for the attack and light bomber role, the Dutch military used them in quite different type of missions – as two-seat fighter aircraft. And as they were rather ill-equipped for such duties, the results were unfortunately equally bad. On 10 May 1940, the crew of this machine, pilot Sgt.vl. J.J de Bruin and observer elt. wnr. H.F.H. van Boekhout attacked a formation of Ju-52 transports, probably shooting one of them down. The Dutch crew successfully avoided the Bf 110 escort fighters hitting back only to fall victim to the anti aircraft fire and crash landed on a meadow where a local farmer was just milking his cows. The Dutch crew borrowed his car and drove to Delft where they got captured by their own soldiers. Only by a coincidence, the pilot was spotted and recognized by his aunt living in Delft as she accidentally met the escort with the prisoners and managed to free her nephew.

SCHEME A

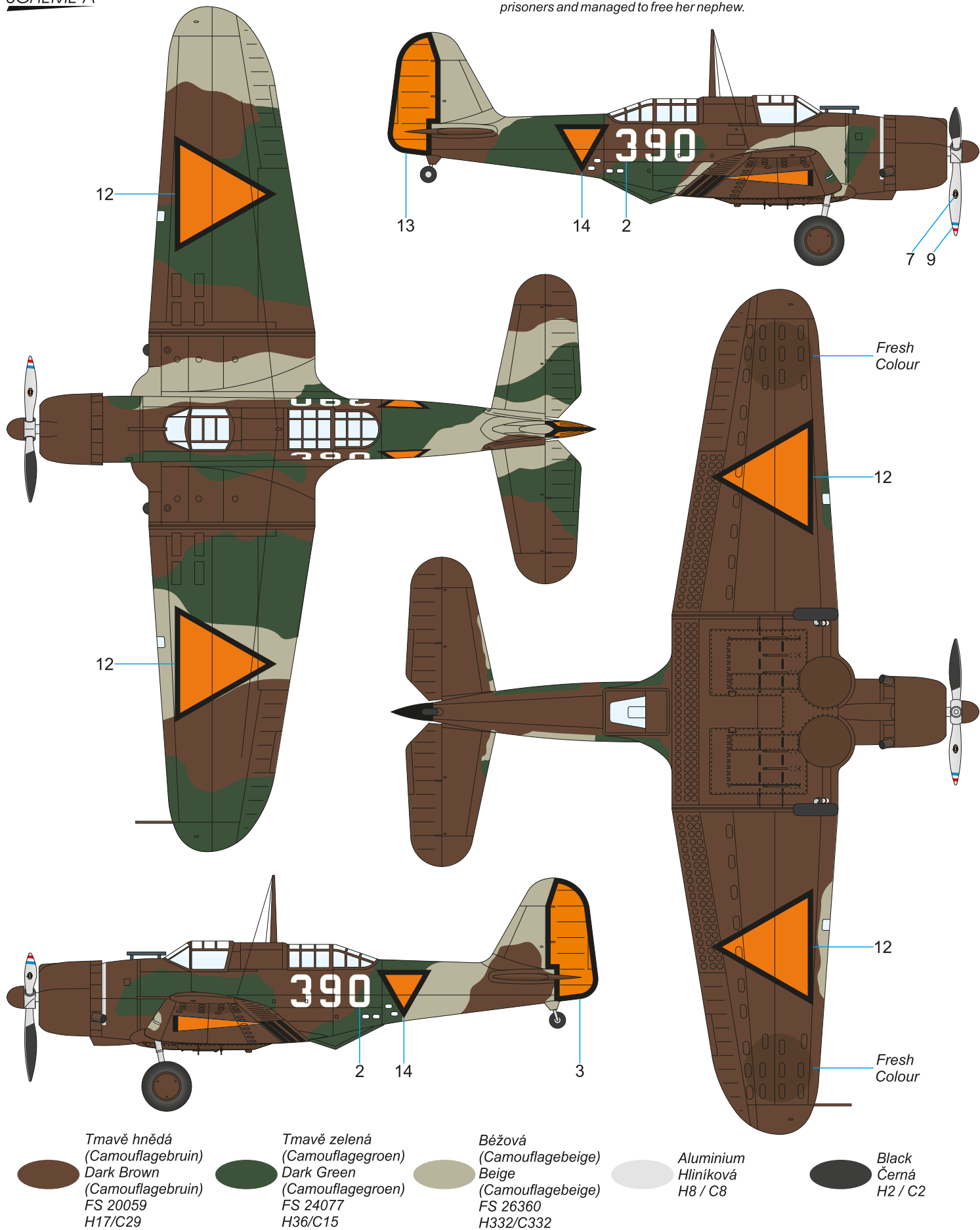

Douglas DB-8A/3N, no. 382, (c/n 532), 3-V-2 Luchtvaart Regiment, Militaire Luchtvaart (holandské vojenské letectvo), 1939. Z USA byly DB-8A/3N dodány se standardními holandskými znaky. Ty se na letounech používaly až do konce září 1939. 1. října byly nahrazeny oranžovými, černě lemovanými trojúhelníky. Ty měly zdůraznit, že letoun přísluší neutrálnímu státu a omezit možnost záměny za francouzské nebo britské kokardy.

Douglas DB-8A/3N, no. 382, (c/n 532), 3-V-2 Luchtvaart Regiment, Militaire Luchtvaart (Dutch air force), 1939. The DB-8A/3N arrived from USA with the standard Dutch markings. Those were used until the end of September 1939. On October 1 they were replaced with orange triangles with black outlines. Those signified that the aircraft belongs to a neutral country as the original markings could have been confused with the French or British colours.

SCHEME B

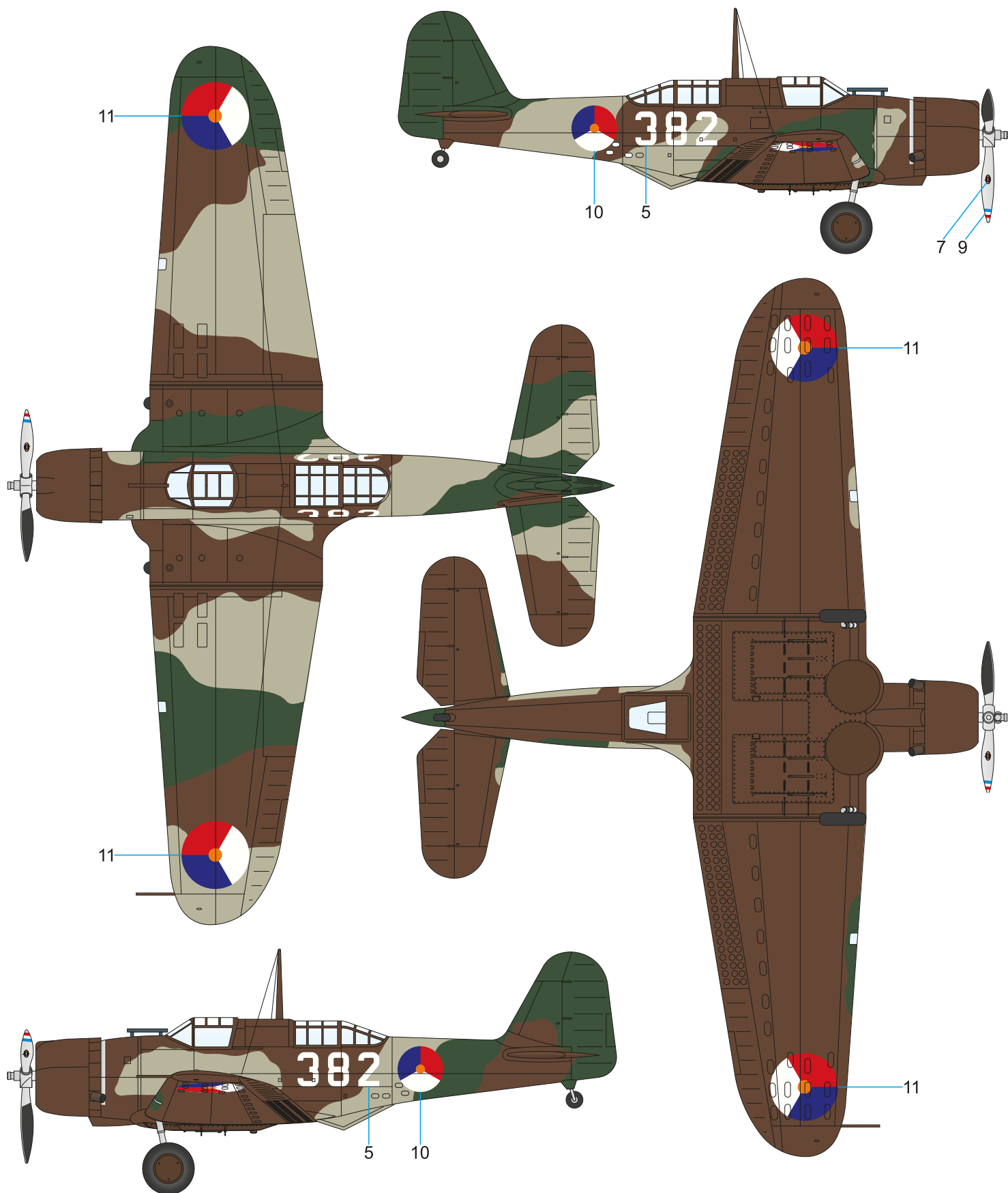

Tmavě hnědá
(Camouflagebruin)
Dark Brown
(Camouflagebruin)
FS 20059
H17/C29

Tmavě zelená
(Camouflagegroen)
Dark Green
(Camouflagegroen)
FS 24077
H36/C15

Běžová
(Camouflagebeige)
Beige
(Camouflagebeige)
FS 26360
H332/C332

Aluminium
Hliníková
H8 / C8

Black
Černá
H2 / C2

Douglas DB-8A/3N, no. 382, (c/n 532), 3-V-2 Luchtvaart Regiment , Militaire Luchtvaart (holandské vojenské letectvo), 1940. 10. května 1940 s tímto letounem osádka pilot Tlt.vl. H.G Guijt a pozorovatel tlt.wnr J. Vonk sestřelila pravděpodobně Ju-52. Německé stíhačky vzápětí sestřelily no.382. Pilot stihl vyskočit a zachránil se na padáku, pozorovatel byl zabit.

Douglas DB-8A/3N, no. 382, (c/n 532), 3-V-2 Luchtvaart Regiment , Militaire Luchtvaart (military aviation in Dutch), 1940. On 10 May 1940, its crew of pilot Tlt.vl. H.G Guijt and observer tlt.wnr J. Vonk scored a possible victory over a Ju-52 transport, only to get shot down themselves moments later by a German fighter aircraft. The pilot managed to bail out to safety while its observer was killed.

SCHEME C

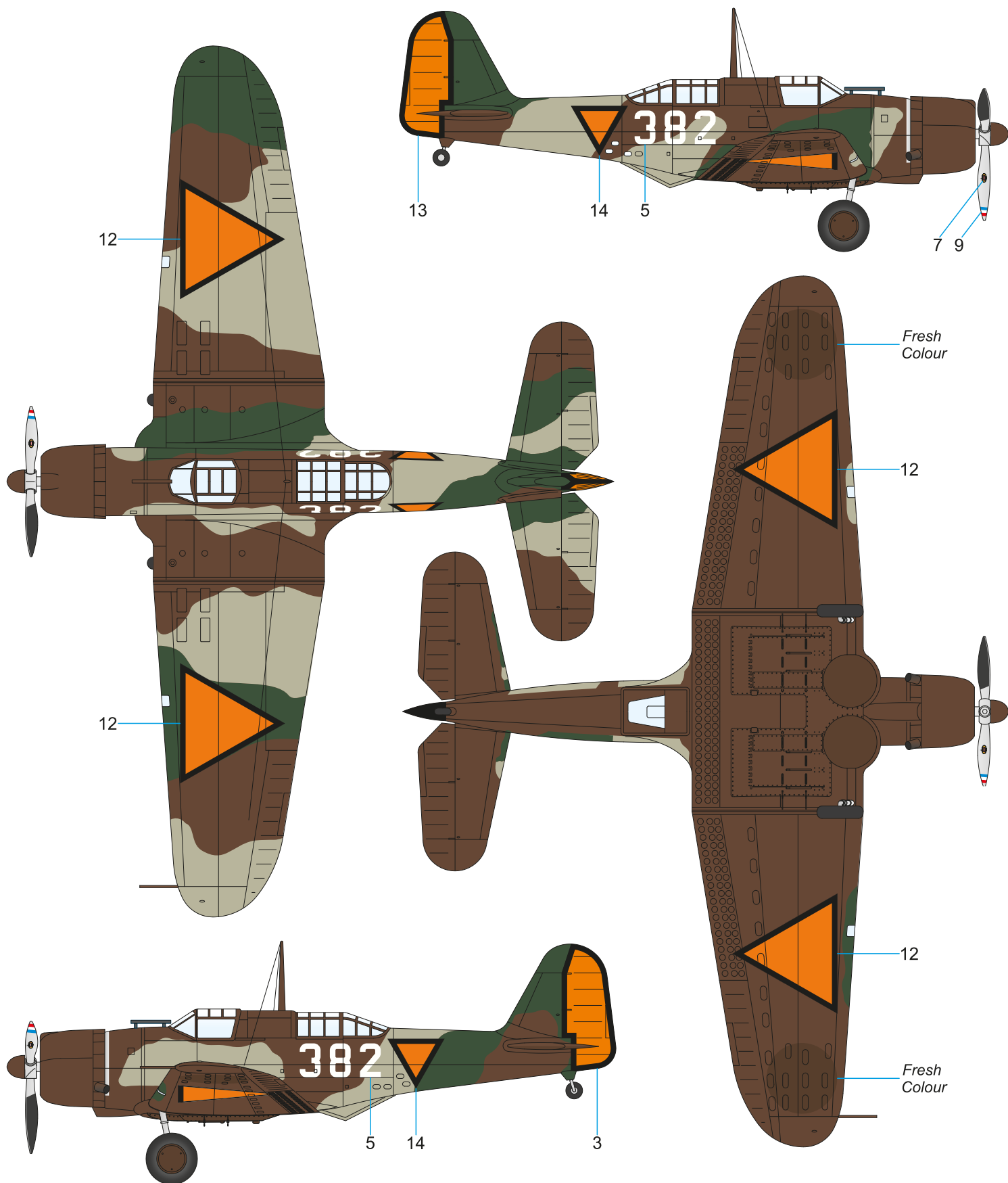

- 

Tmavě hnědá
(Camouflagebruin)
Dark Brown
(Camouflagebruin)
FS 20059
H17/C29
- 

Tmavě zelená
(Camouflagegroen)
Dark Green
(Camouflagegroen)
FS 24077
H36/C15
- 

Běžová
(Camouflagebeige)
Beige
(Camouflagebeige)
FS 26360
H332/C332
- 

Aluminium
Hliníková
H8 / C8
- 

Black
Černá
H2 / C2

SCHEME D

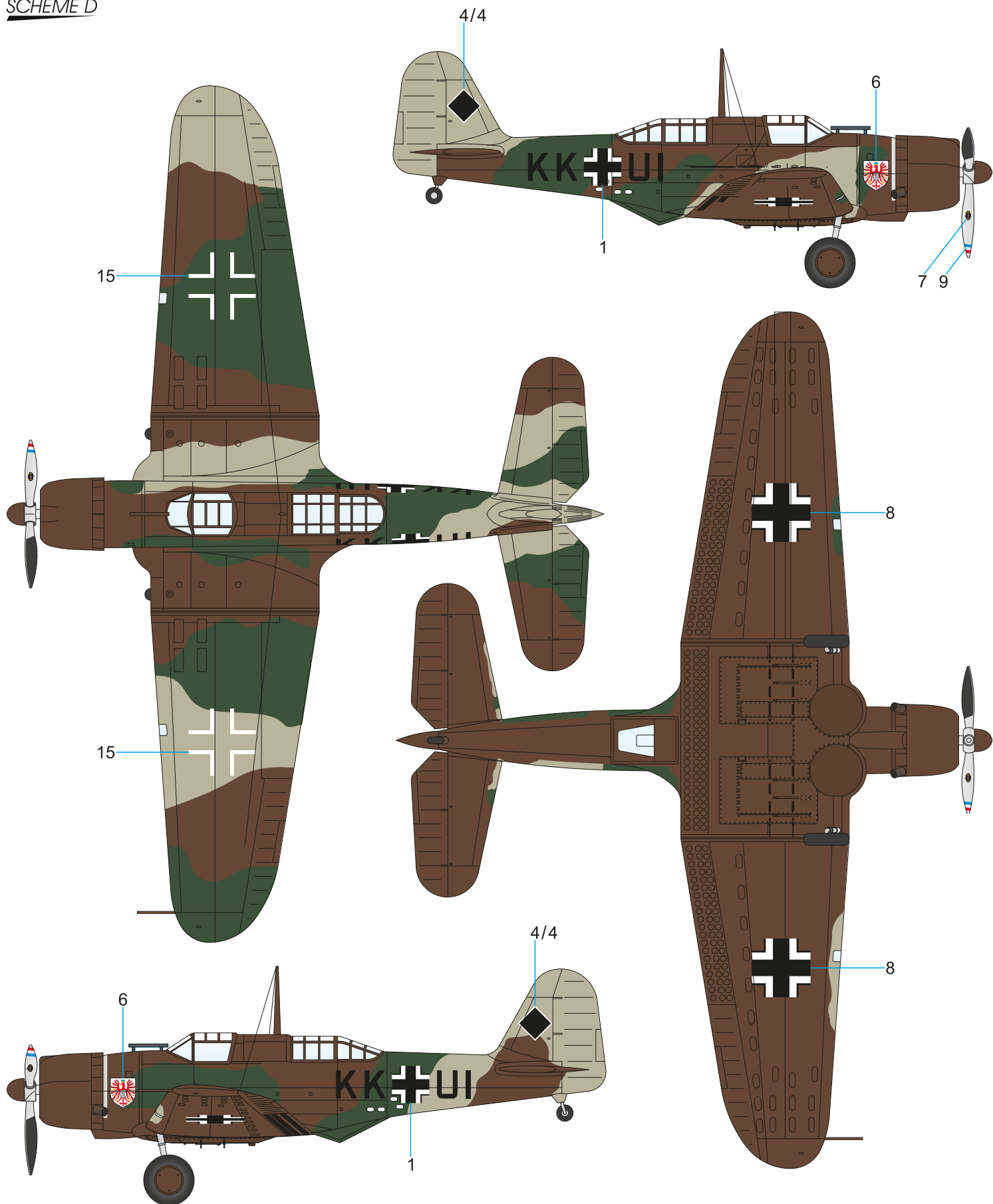

 Tmavě hnědá
(Camouflagebruin)
Dark Brown
(Camouflagebruin)
FS 20059
H17/C29

 Tmavě zelená
(Camouflagegroen)
Dark Green
(Camouflagegroen)
FS 24077
H36/C15

 Běžová
(Camouflagebeige)
Beige
(Camouflagebeige)
FS 26360
H332/C332

 Aluminium
Hliníková
H8 / C8

 Black
Černá
H2 / C2

1/72
SH72431



Supermarine Sea Otter Mk.I/ASR Mk.II ,Foreign Service'

M72042 Meteor T Mk.7 MASK **Special MASK**

1/72 SH72468

Meteor T Mk.7



1/72 SH72451 **SF-260 Duo Pack & Book**

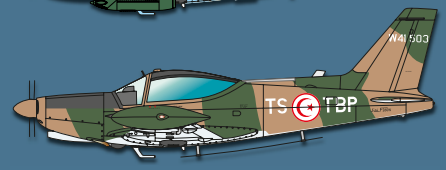
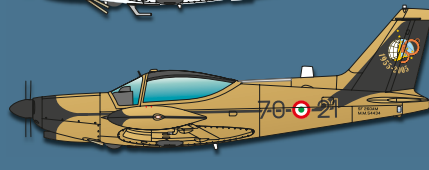
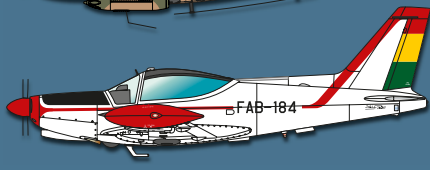
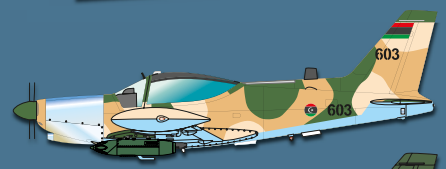
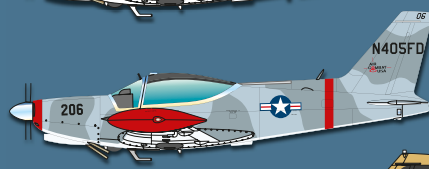
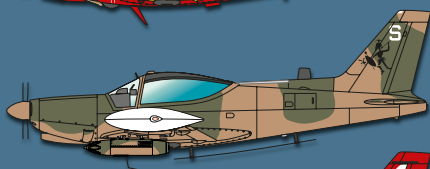
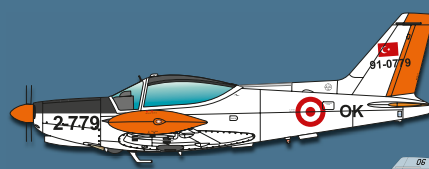
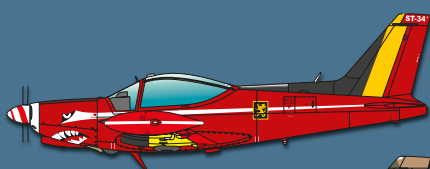



Heinkel He 162A Spatz 'Captured Birds'

SH 72475

To spruce up your Heinkel He162A you can use these resin sets: 7443, 7444, Q72361, Q72362. Your work can be made easier with the pre-cut mask for clear parts and wheels, M72030 (sold separately). We also offer the resin figures F72365 and F72372 to go with the Heinkel He 162A.



7443

Heinkel He 162A Engine
(BMW 003 Jet Engine)



Q72361

Heinkel He 162A
Ejection Seat

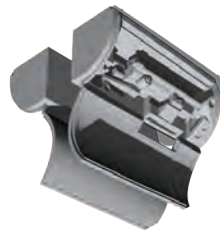

7444

Heinkel He 162A Gun bays
(BMW 003 Jet Engine)



Q72362

Heinkel He 162A
Wheels

Special
MASK

M72030
Heinkel
He 162
MASK



F72365

Three Pilot Figures, Each in Different Gear:
Great Coat, Flying Suit, Breeches



F72372

German He 162A
Mechanics (2 figures)



F72346

Ox towing a Me 163B w/2 Luftwaffe
Around Crew



F72229

WWII German Pilots At Rest