

4450 Lancaster Mk.I/III
1/48 Mainwheels and Tailskid w/Wheel
 for HK Models kit

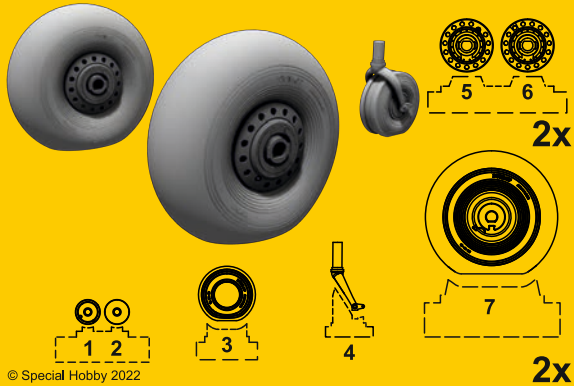

PUR - Polyurethane parts



© Special Hobby 2022

Díly ohnuté popř. pokroutené vlivem teplotních změn a stárnutí materiálu, mohou být narovnaný do požadovaného tvaru pomocí proudu teplé vody nebo vzduchu (fén na vlasy). K lepení použít kvanoakrylátové lepidlo! Kontaktní plochy doporučujeme před lepením odmastit. Různé drátky a tyčinky nejsou přiloženy.

Parts slightly distorted and bent owing to temperature changes or due to material aging can be straightened to requested shape by hot water or hot air jet (hair dryer). This process can be repeated till result is entirely satisfactory. For best result use cyanoacrylate glue! Ungreasing contact areas is recommended before gluing. Wires and rods not included.

Visit our official website and e-shop at
www.cmkkits.com
www.specialhobby.eu
www.facebook.com/specialhobby/

H1020
Razor Saw Profi Set

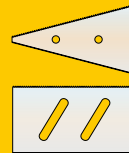

The set contains
 one holder, one
 H1018 Triangle Razor
 Saw and one H1019
 Multi-shift Razor Saw.
 Attach the razor blade to
 the holder as shown in the
 pictures using the plate with
 holes and screws.

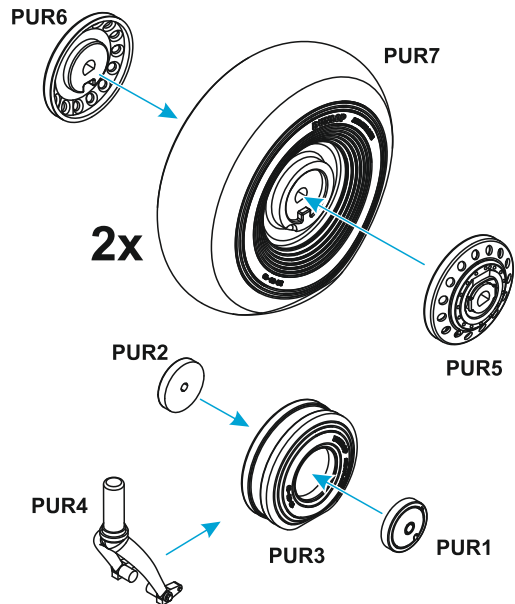

Special Hobby offers for Lancaster Mk.I/III
 (HK Models kit) CMK 4449 Lancaster Mk.I/III Exhausts,
 CMK 4334 Browning 303 Mk. II Machinegun and CMK 4294
 WW II RAF HC Bomb Mk.I 'Cookies' 4000lb (2 pcs) as well.

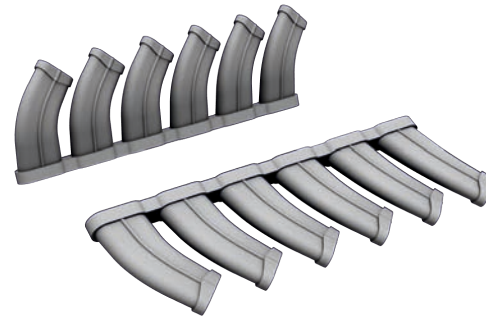

4449
Lancaster Mk.I/III Exhausts

Special Hobby, Mezilesí 718, Praha 9, 193 00, Czech Republic
 e-mail: office@specialhobby.eu