

**P72002 Junkers Ju 87D/G
1/72 Gunner's Seat
and MG 81Z machine gun**
for Academy and Special Hobby kits



3D-Printed Parts



PP1



PP3



PP2

© Special Hobby 2022

**Sedačku i kulomet do modelu vlepťe
dle návodu stavebnice Special Hobby.
Návod najdete na www.specialhobby.eu**

PP2

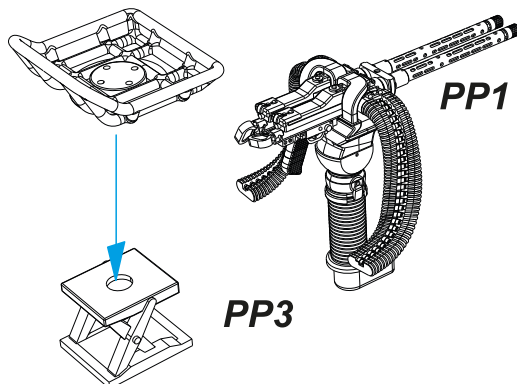

**To glue the seat and the machinegun to
the kit follow the instructions for the Special
Hobby kit (download it
at www.specialhobby.eu).**

Resinové díly ohnuté popř. pokroucené vlivem teplotních změn a stárnutí materiálu, mohou být narovnaný do požadovaného tvaru pomocí proudu teplé vody nebo vzduchu (fén na vlasy). Ohnuté 3D tisky narovnejte ponořením do horké vody, srovnejte je a zchlďte studenou vodou. K lepení použít kyanoakrylátové lepidlo! Kontaktní plochy doporučujeme před lepením odmastit.
Různé drátky a tyčinky nejsou přiloženy.

Parts slightly distorted and bent owing to temperature changes or due to material aging can be straightened to requested shape by hot water or hot air jet (hair dryer). This process can be repeated till result is entirely satisfactory. You can also correct bent 3D printed parts: put them into hot water, straighten them and cool them in cold water. For best result use cyanoacrylate glue! Ungreasing contact areas is recommended before gluing. Wires and rods not included.

**Visit our official website and e-shop at
www.cmkkits.com
www.specialhobby.eu
www.facebook.com/specialhobby/**

**other 1/72 3D printed sets
P72001 Focke Wulf Fw 190A/D Seat
and future sets.....**

Special Hobby, Mezilesí 718, Praha 9, 193 00, Czech Republic
e-mail: office@specialhobby.eu

CMK 1/72 CMK SETS for Fw 190D (IBG kits)

**Q72400
Fw 190D Wheels**

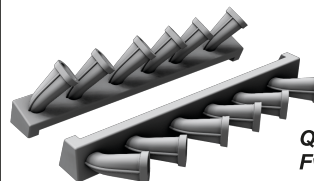

**Q72399
Fw 190D Exhausts**

**P72001
Fw 190A/D Seat**



and more at www.specialhobby.eu