

## Sd.Kfz 250 captured

**1/72**

### CZ

Sd.Kfz 250 byl vyvinut na základě požadavků Wehrmachtu na rozvoj výstavby jednotek polopásových transportérů. Během plánování požadavků na jednotlivé kategorie polopásových transportérů vyvstala potřeba menšího a levnějšího vozidla, než byl standardní polopás Sd.Kfz 251. V rámci urychlení vývoje byla použita podvozková skupina nepancéřovaného vozidla Demag D7 (Sd.Kfz 10). Pro tu byla firmou Büssing zkonstruována pancéřová nástavba. Ta byla svařována z pancéřových desek navazujícími na sebe pod značnými úhly. Tím byla zvýšena odolnost proti odstřelování. Nástavba měla šestiúhelníkový tvar. První prototyp byl postaven v roce 1939. Následovaly ho další prototypy, intenzivně testované. Náročnými testy ověřené stroje se začaly sériově vyrábět v roce 1941. Podobně jako u Sd.Kfz 10 byl původně montovaný motor Maybach HL 38 u sériových Sd.kfz 250 nahrazen spolehlivějším HL 42 se stejným výkonem. Do konce roku 1941 Wehrmacht dostal 39 kusů, velkosériová produkce provedení Sd.Kfz 250 později nazvaného Alte Ausführung běžela celý rok 1942 a část roku 1943. V roce 1943 se začala vyrábět provedení Sd.Kfz 250 Neue Ausführung. Tvar pancéřové vany byl změněn na výrobně jednodušší obdélníkový. Výroba běžela až do konce roku 1944, kdy byla zastavena. Celkově bylo vyrobeno skoro 6000 těchto výborných strojů v mnoha variantách. Důvodem zastavení výroby byla celková krize produkce německých továren a snaha po zjednodušení a zlevnění výroby. Standardním polopásovým vozidlem Wehrmachtu měl být větší Sd.Kfz 251. K náhradě ale nedošlo. Sd.Kfz 250 bojovaly v první linii až konce druhé světové války. Nasazeny byly na východní i západní frontě a část strojů bojovala i v Africe. Po válce byly krátce používány v několika armádách, včetně československé. Podobně jako jiné bojové stroje Wehrmachtu byl Sd.Kfz 250 obou provedení dodáván v mnoha variantách. Ty označovalo lomítkem a číslicí za ním. Sd.Kfz 250/1 byl standardní transportér pěchoty pro polovinu družstva. Sd.Kfz 250/2 sloužil ke kladení linek polního telefonu, Sd.Kfz 250/3 bylo velitelské vozidlo s různými typy radiovybavení. Varianty Sd.Kfz 250/4 a /5 sloužily k průzkumu, Sd.Kfz 250/6 sloužil jako transportér munice pro samohybná děla Stug III. Jako pohyblivý minomet sloužila varianta Sd.Kfz 250/7. Sd.Kfz 250/8, /9, /10 a /11 byly vybaveny různými typy protitankových zbraní. Poslední oficiální variantou se stala verze Sd.Kfz 250/12, sloužící jako mobilní stanoviště řízení palby. Další výzbrojní varianty vznikly na frontě či v opravárenských jednotkách iniciativou vojáků. Základní Sd.Kfz 250 posloužil k vývoji typů Sd.Kfz 252 a Sd.Kfz 253. Sd.Kfz 252 bylo speciální vozidlo pro dopravu munice v oblasti bojů. Sd.Kfz 253 pak průzkumné vozidlo pro spolupráci se svazky tankových jednotek nebo jednotek útočných děl. Vzhledově odpovídalo Sd.Kfz 250, ale prostor osádky, u Sd.Kfz 250 otevřený, byl u Sd.Kfz 253 uzavřen pancéřovou deskou s dvěma průlezy.

### EN

The Sd.Kfz 250 half track vehicle was developed to the Wehrmacht requirements calling for growing development of half track transporter units. While planning the respective categories of the half track vehicles, the need arose for a vehicle smaller and cheaper than was the Sd.Kfz 251, by then already in standard service. To speed up the development of such a vehicle, a chassis the unarmoured Demag D7 (Sd.Kfz 10) halftrack was used and a new, armoured body constructed by Büssing company. This hull armour plates were welded in rather considerable angles, giving the vehicle a degree of safety from enemy fire. The hull was of a hexagonal shape. The prototype vehicle was built in 1939, soon to be followed by a few more ones, all of which were put to rather demanding tests. The mass production of the test-proven design commenced in 1941. At first, the vehicles were powered by a Maybach HL 38 engine which in production Sd.Kfz 250 vehicles was later replaced by a HL 42 type of the same power, in a manner similar to the Sd.Kfz 10. By the end of 1941, the Wehrmacht received 39 vehicles. The mass production of the early type later called Alte Ausführung ran for the whole next year and for a couple of months of 1943, when the version was replaced by a newer one known as the Sd.Kfz 250 Neue Ausführung. Its hull was of a simplified, rectangular shape, easier to produce. The production lasted until the end of 1944 when it was stopped. In total, almost 6000 of these excellent vehicles were produced in many variants. The reason for halting the production was partly the crisis of the production from German factories, partly because of the effort to make the production less demanding and less expensive – the larger Sd.Kfz was expected to become the standard halftrack transport vehicle of the Wehrmacht. The replacement did not realize in the end, though. The Sd.Kfz 250 fought in the front line service until the end of the war. They were used on both the Eastern and Western fronts, some of the machines found themselves also in Africa. In the post war period, they served with armies of some other countries as well, including that of Czechoslovakia. As well as other Wehrmacht vehicles, both versions of the Sd.Kfz 250 were delivered in many varieties, designated by a numeral behind the slash. The Sd.Kfz 250/1 was a standard troop carrier able to carry half a squad. The Sd.Kfz 250/2 was equipped with a cable-laying gear, the Sd.Kfz 250/3 was a command radio vehicle. Both the Sd.Kfz 250/4 and 250/5 were reconnaissance vehicles with various types of radio equipment. The 250/6 variant was an ammunition transporter for the Stug III assault gun. The 250/7 carried an 81mm mortar and variants 250/8 to 250/11 were equipped with various sorts of anti-tank armament. The final, officially recognized variant was the Sd.Kfz 250/12 fitted for range spotting and fire control. Further variants were also created, both at the front and in rear line repair units, by the initiative of military personnel. The basic Sd.Kfz 250 type gave rise to the development of the Sd.Kfz 252 and 253, the former of which was a specialized, ammunition carrying vehicle operating on battlefield, the latter was a reconnaissance vehicle cooperating with tank or assault gun units. In overall appearance it was similar to the Sd.Kfz 250 but its hull was enclosed by an armour plate with two manholes, while the body of the Sd.Kfz 250 was open on the top.

# Plastic Parts

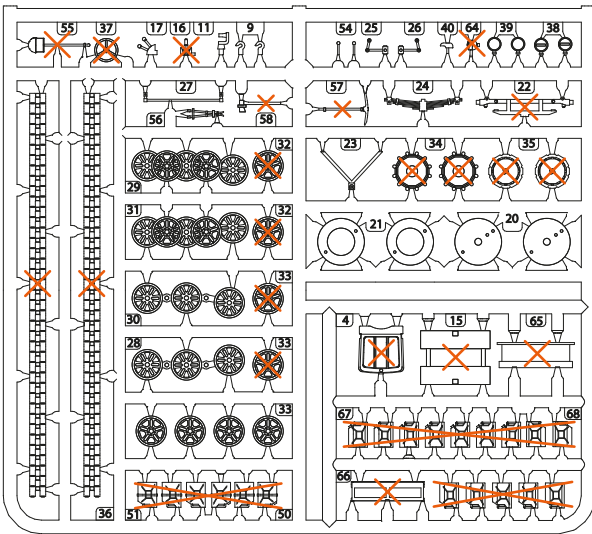
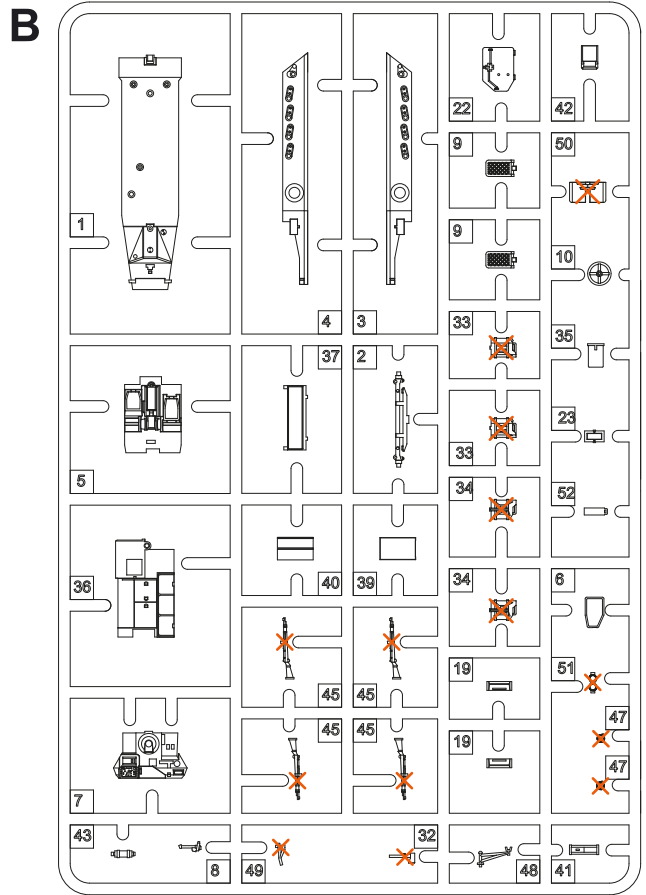
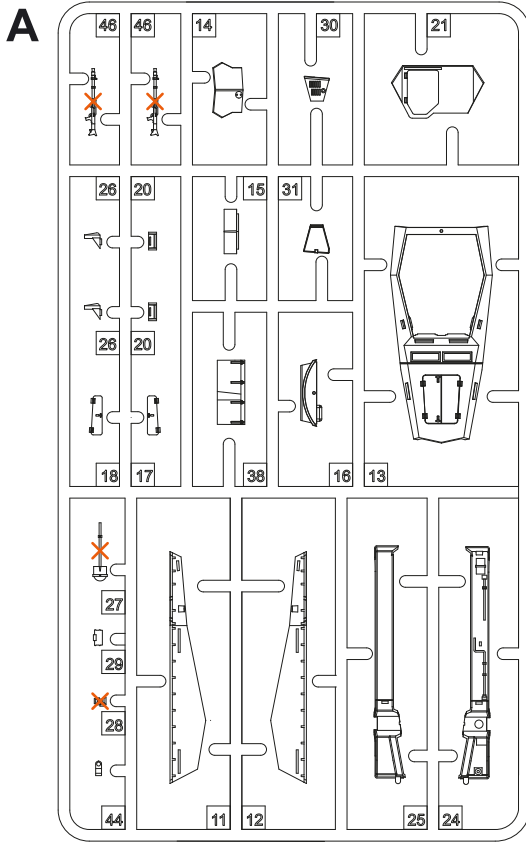

C

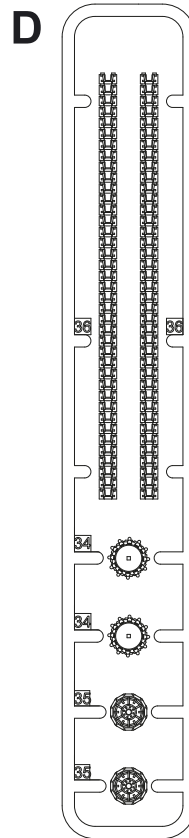

D

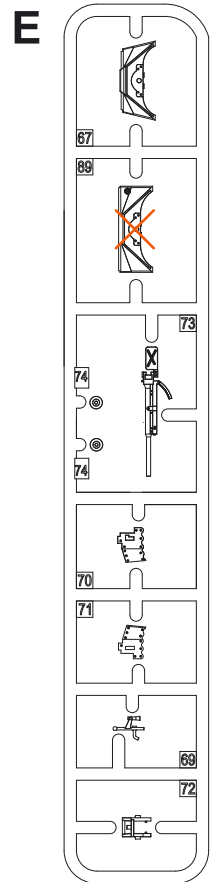

E

## Barvy GUNZE/ GUNZE Colour No.

<b>A</b>	Ruská zelená / Russian Green	H511 / C511
<b>B</b>	Ocelová / Steel	H18 / C28
	Tmavá žlutá / Dark Yellow RAL 7028	H79 / C39
	Olivově zelená / Olive Green	H420 / C120
	Barva pneu / Tyre Black	H77 / C137

## SYMBOLS



MOŽNOST VOLBY  
OPTIONAL  
NACH BELIEBEN  
OPTION



POUŽIT KYANOAKRYLÁTOVÉ LEPIDLO  
INSTANT CYANOACRYLATE GLUE  
ZYANOAKRYLÁTKLEBER  
COLLE CYANOACRYLAT



OHNOUT  
BEND  
BIEGEN  
COURBER



ZHOTOVIT NOVÉ  
SCRATCH BUILD  
FERTIGSTELLEN  
ACHEVER



ŘEZAT/VRTAT  
CUT OFF/DRILL  
ENTFERNEN  
DETACHER

GSI  
colour code

NATRÍT  
COLOUR  
FARBEN  
PEINDRE

**STEP 1**

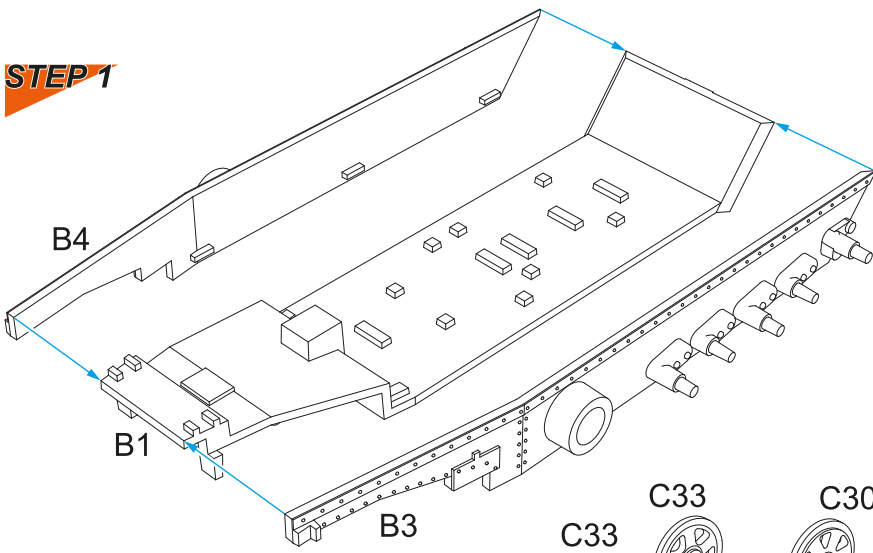

**STEP 2 2x**

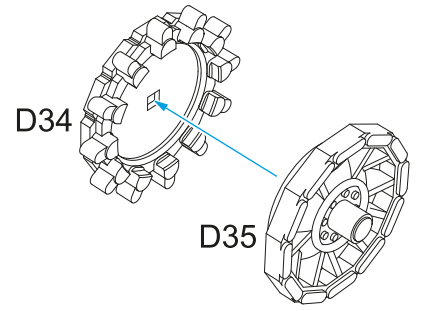

**STEP 3**

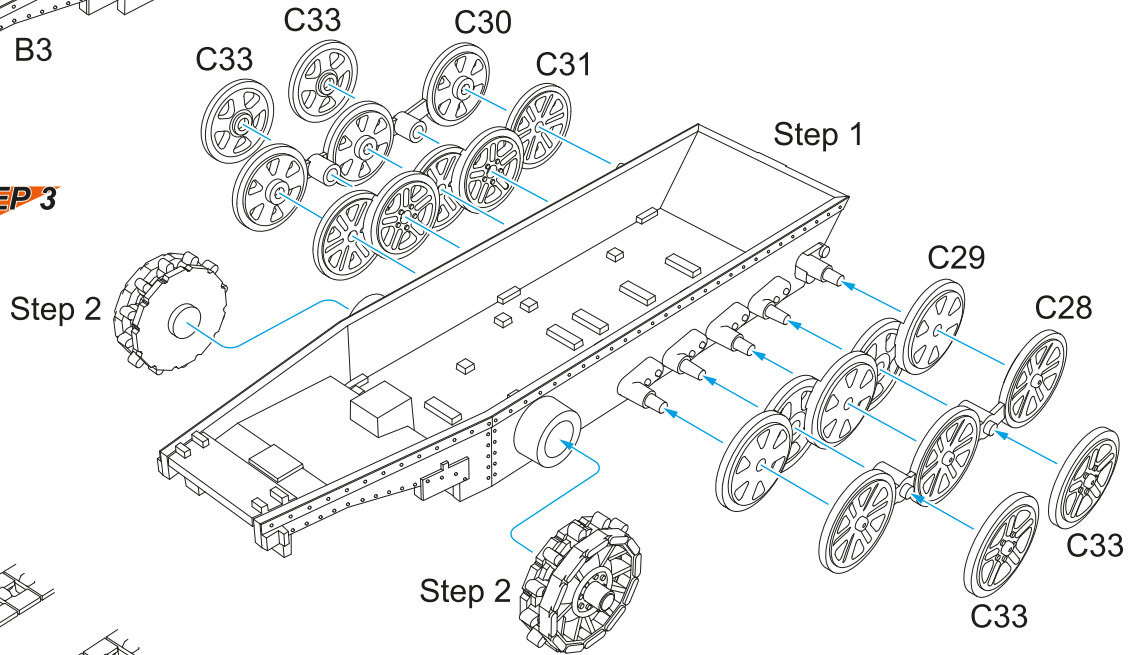

**STEP 4**

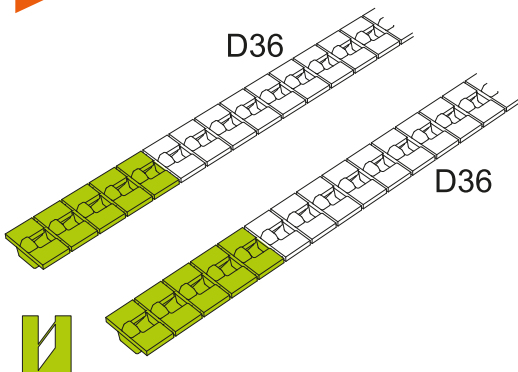

**STEP 5**

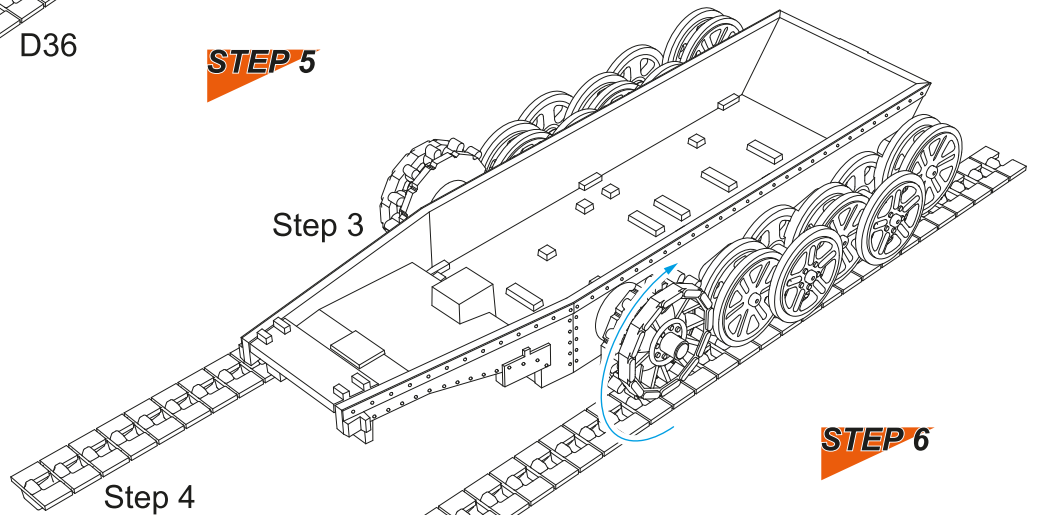

**STEP 6**

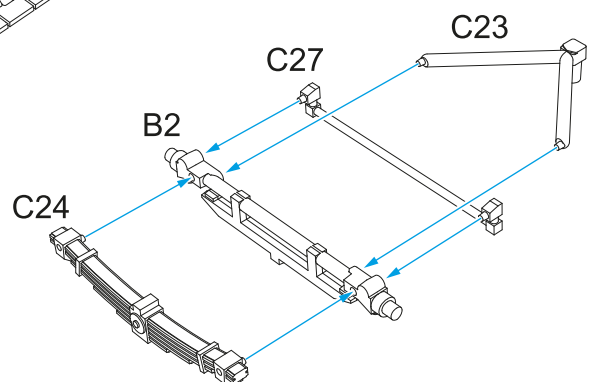

**STEP 7 2x**

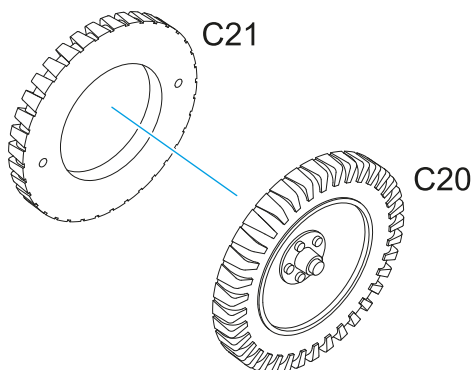

**STEP 8**

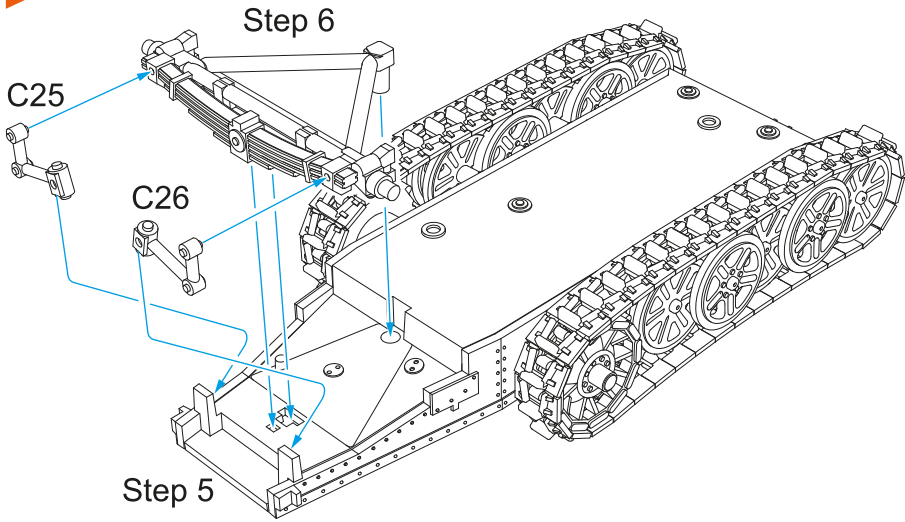

**STEP 9**

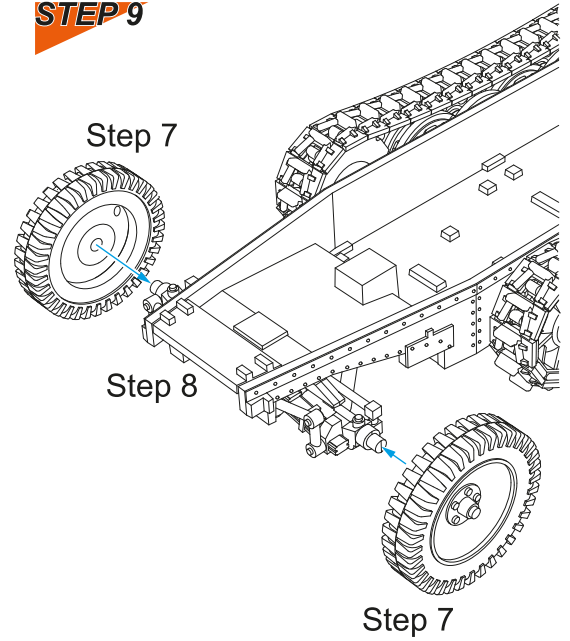

**STEP 10**

**STEP 11**

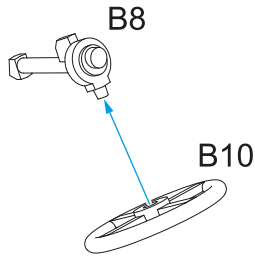
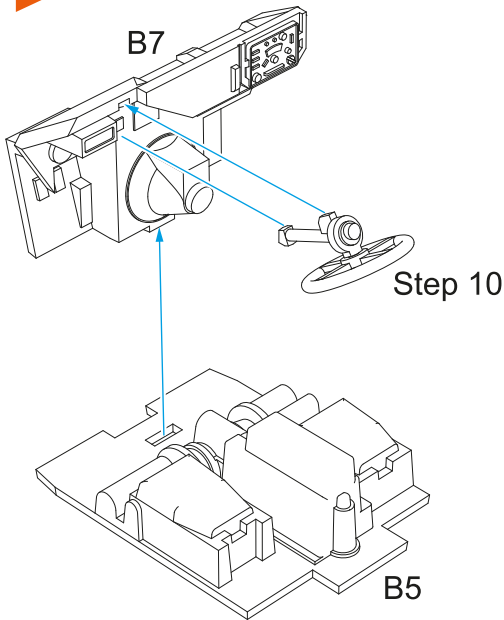

**STEP 12**

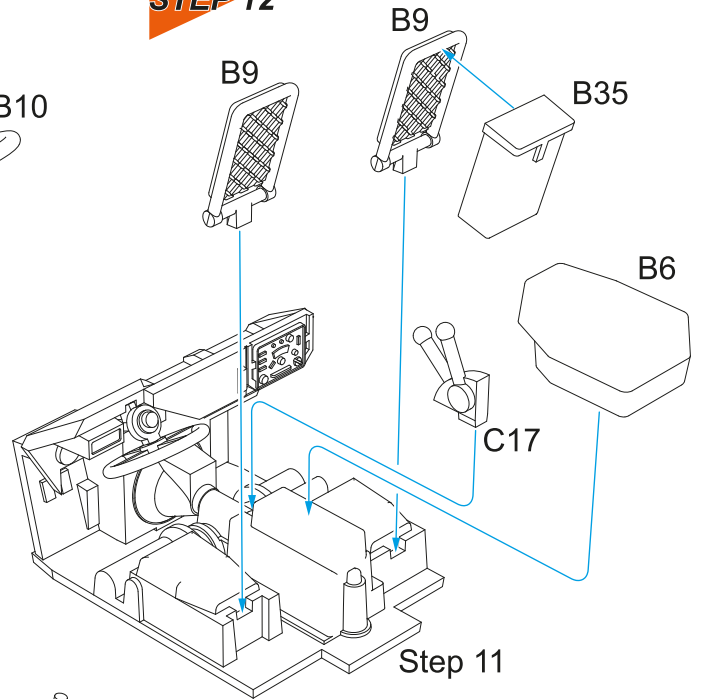

**STEP 13**

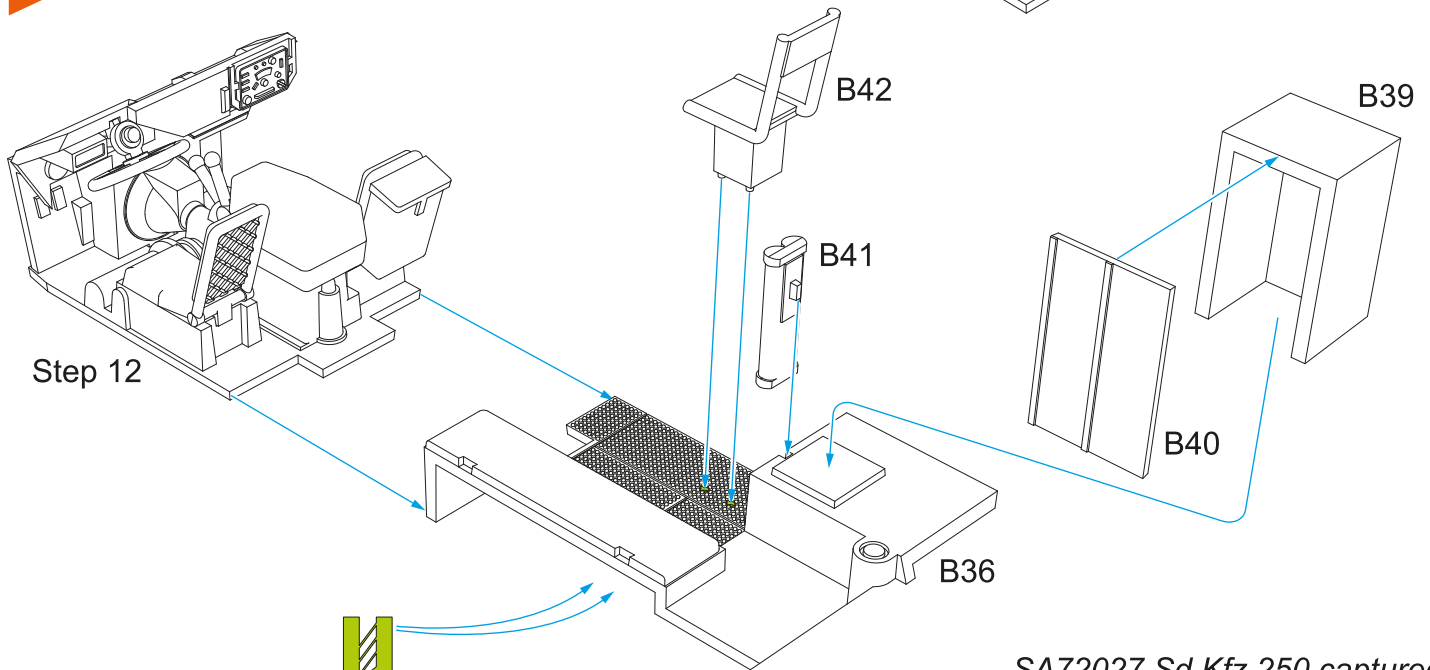

**STEP 14**

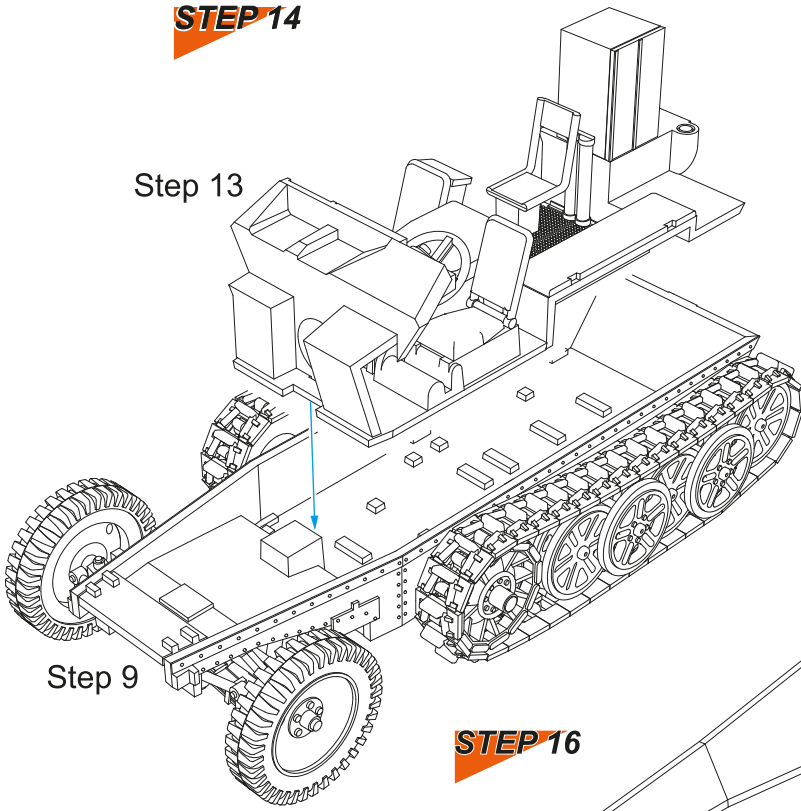

**STEP 15**

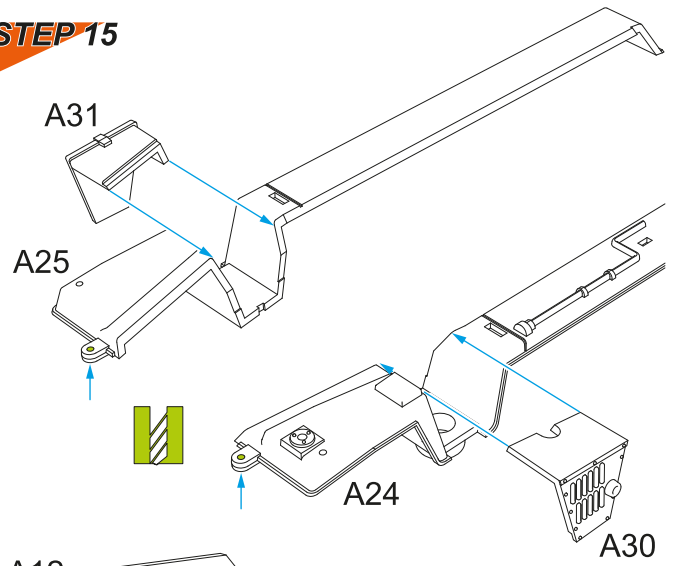

**STEP 16**

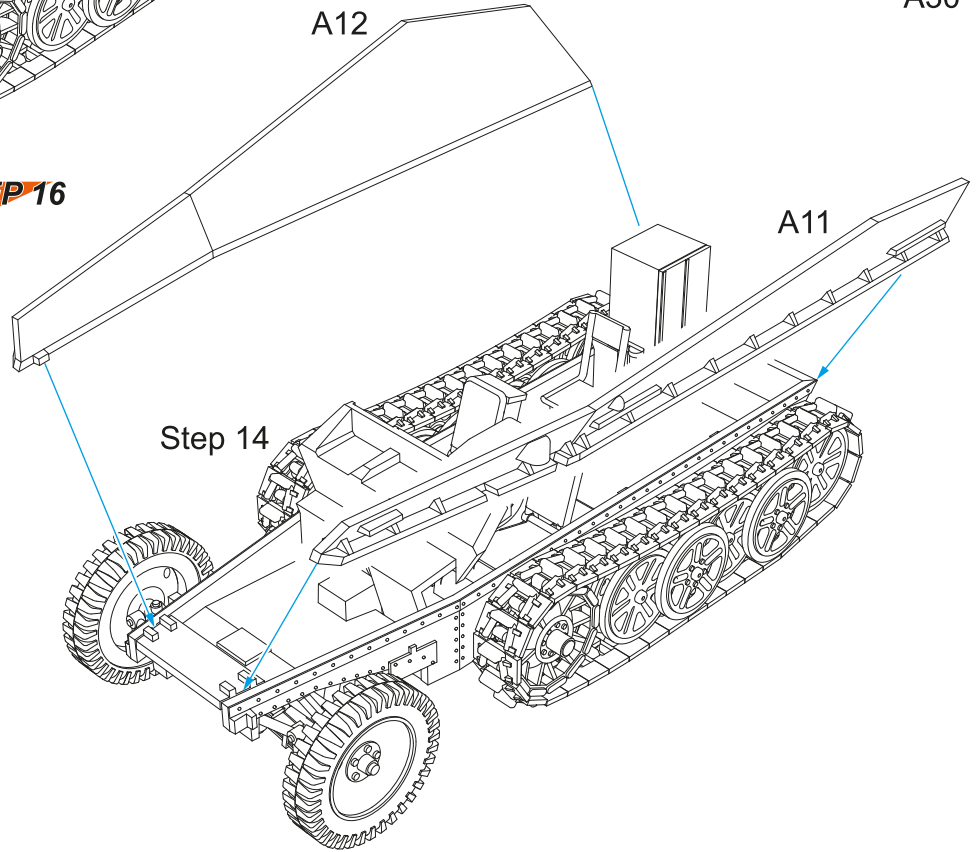

**STEP 17**

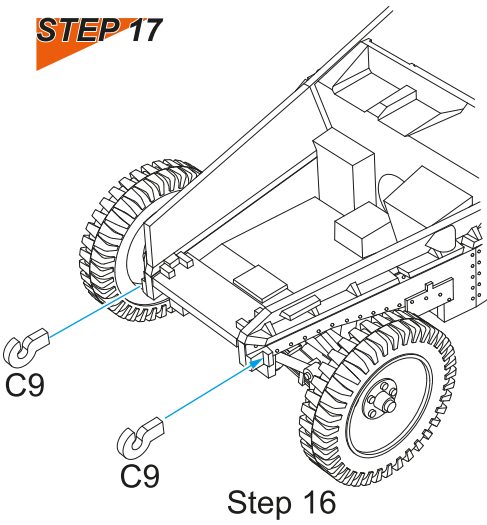

**STEP 18**

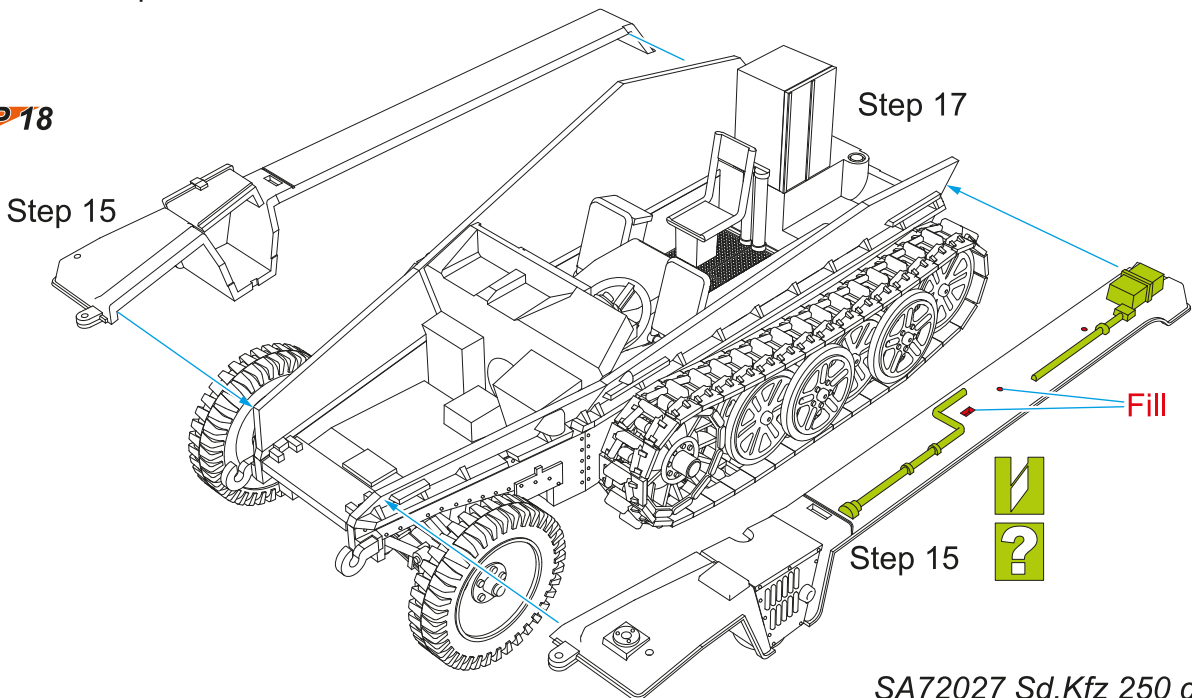

**STEP 19**

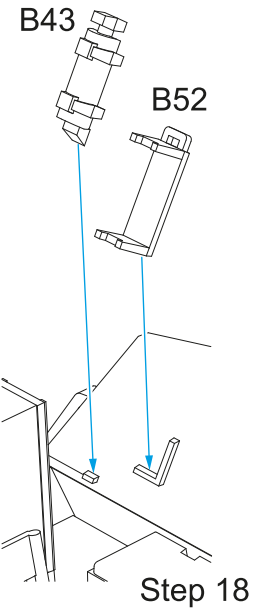

**STEP 20**

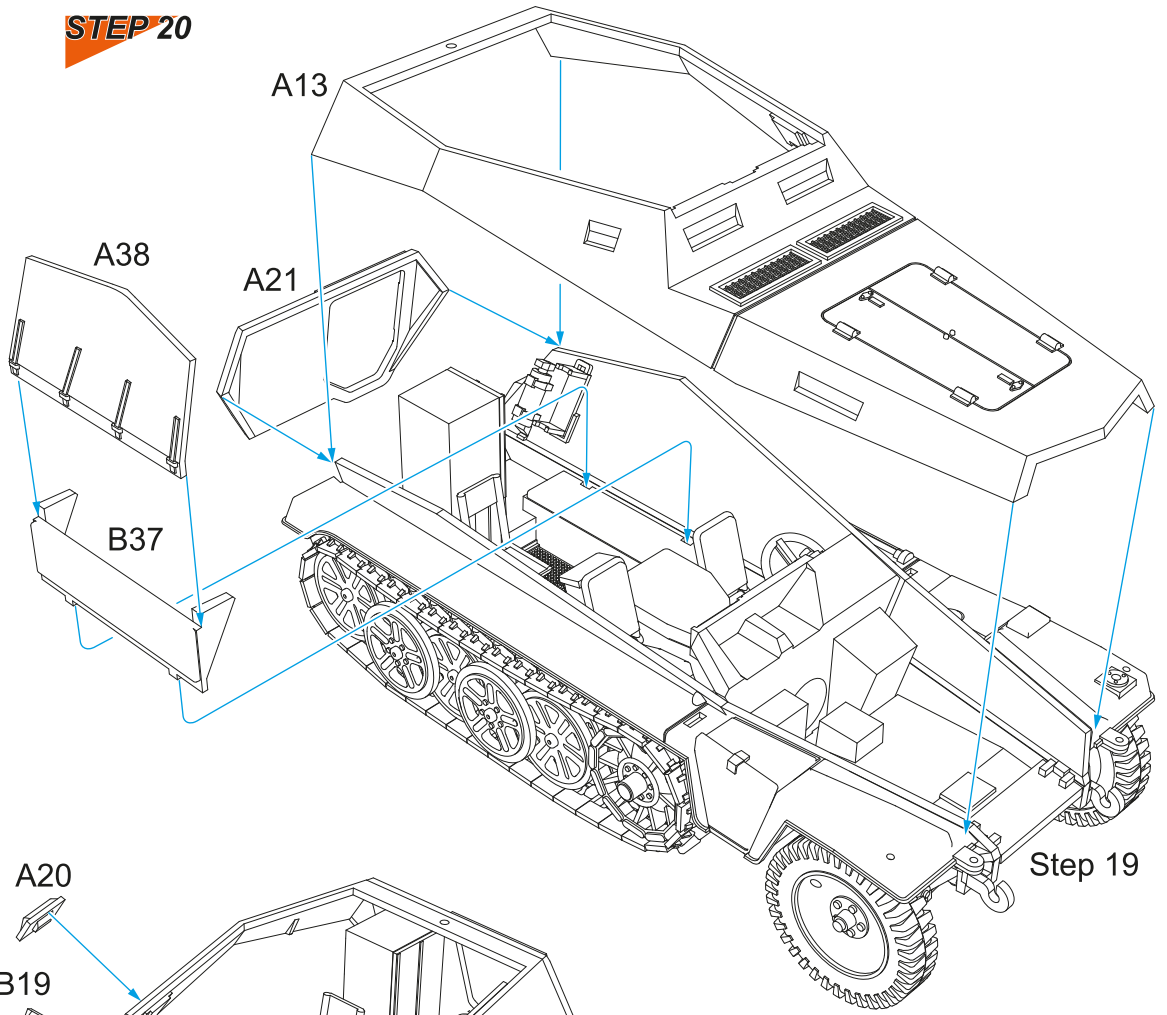

**STEP 21**

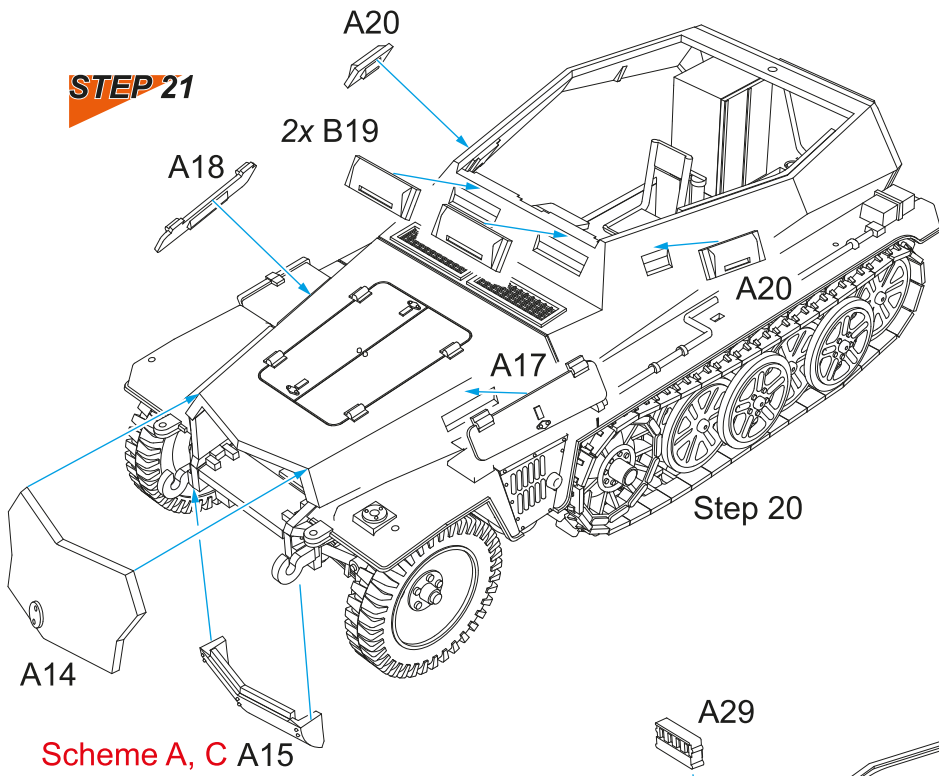

Ø 0.3mm x 20mm

A44 Scheme C

**STEP 22**

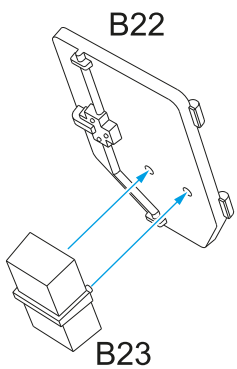

**STEP 23**

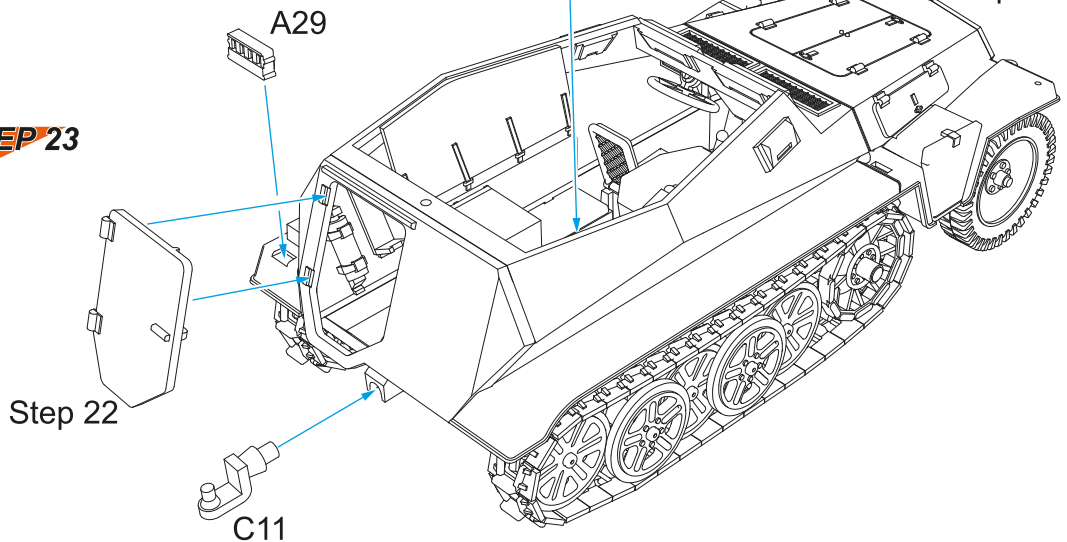

## STEP 24 ?

Scheme C

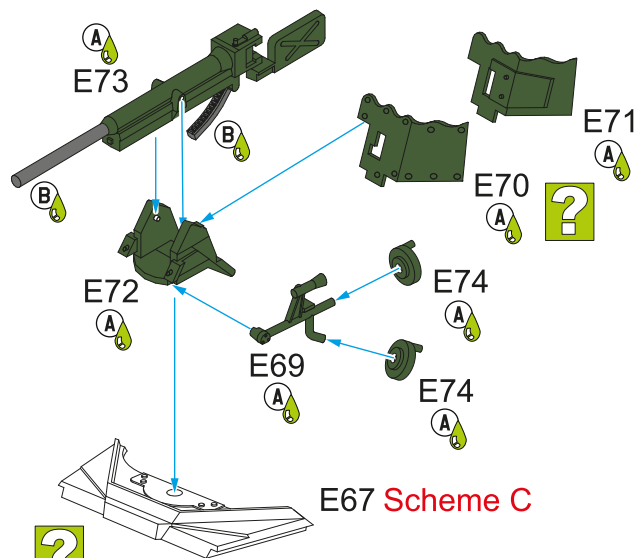

## STEP 25

Scheme A, B

A16

A26



B48 Scheme C

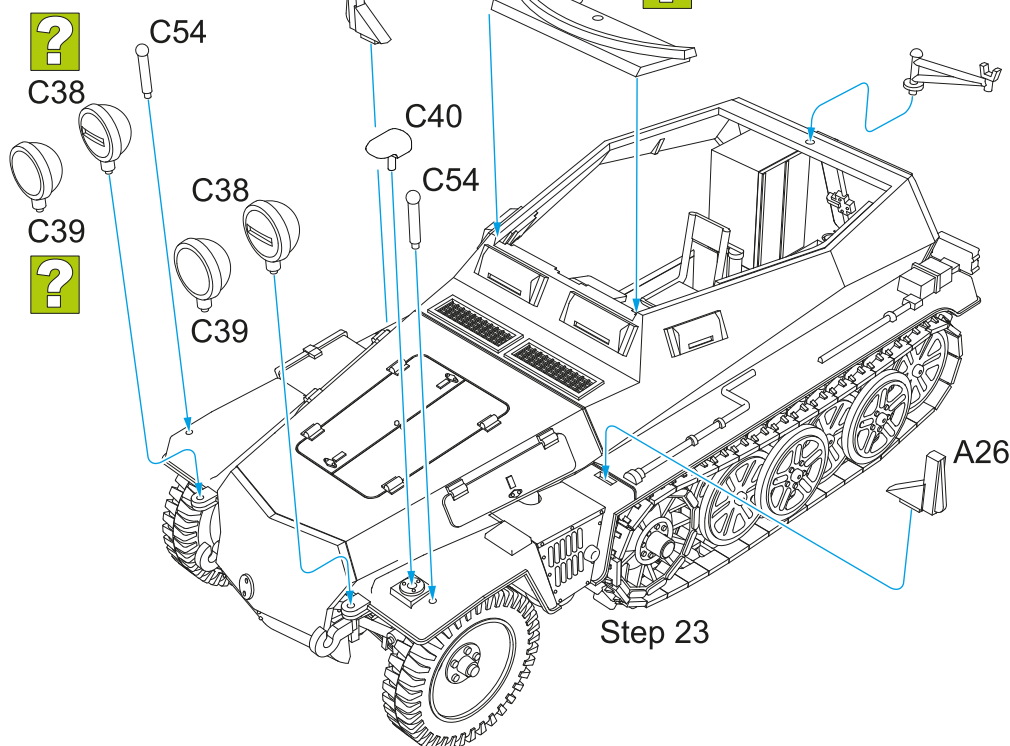

Světla C39 použijte  
pro schéma B  
Světla C38 použijte  
pro schéma C

Head lights parts C39  
- scheme B  
Head lights parts C38  
- scheme C

### Camo A

Sd.Kfz 250 'Malá Housenka', povstalecká jednotka npor. Neubauera, Praha Žižkov, 8. května 1945. O den později, 9. května 1945 v 15,00 dostalo toto vozidlo zásah dělostřeleckým granátem na pražském Zlíchově (část Prahy 5). Ve vozidle zahynuli četař v záloze J. Doubrava, svobodníci v záloze J. Port a A. Kašťánek a vojín v záloze K. Nemastil. S těžkými zraněními přežil jen řidič vojín v záloze J. Prošek.

Sd.Kfz 250 'Small Caterpillar', insurgent unit led by 1st Lt. Neubauer, Prague-Zizkov, 8 May 1945. Only a day later on 9 May 1945 at 1500hrs the vehicle got hit by an artillery shell in Prague 5, Zlichov. The crew of sergeant (res.) J. Doubrava, corporals (res.) J. Port and A. Kastanek and private (res.) K. Nemastil were killed. Only the driver private (res.) J. Prošek survived although severely wounded.

### Camo B

Sd.Kfz 10, kořistní vozidlo US Army, ukořistěné během battle of Bulge, Bastogne, Belgie, přelom let 1944/45.

Sd.Kfz 10, vehicle captured by the US Army during the Battle of the Bulge, Bastogne, Belgium, 1944/45.

### Camo C

Sd.Kfz 205/10, kořistní vozidlo, používané vojáky 13. Pułk Artylerii Samobieźnej, Ludowe wojsko Polskie (13. pluk samohybného dělostřelectva, Polská Lidová armáda).

Sd.Kfz 205/10, captured vehicle operated by the troops of the 13. Pułk Artylerii Samobieźnej, Ludowe wojsko Polskie (13th Self-propelled Artillery Regiment, Polish People's Army).

**Camo A**

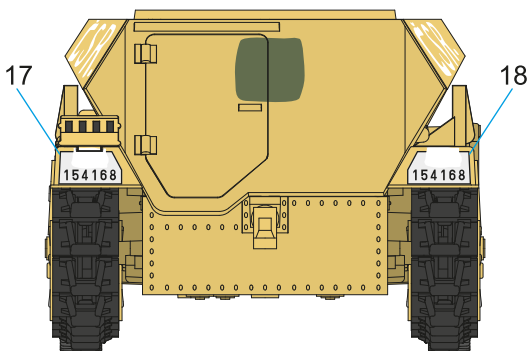
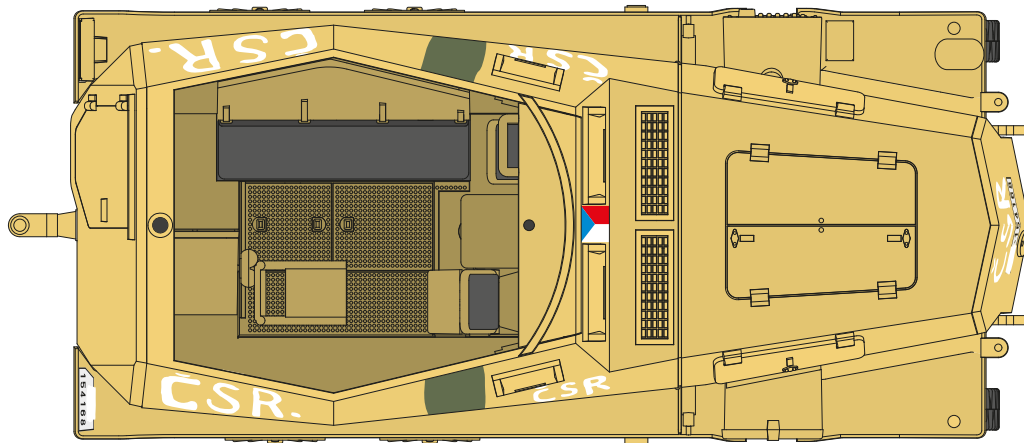
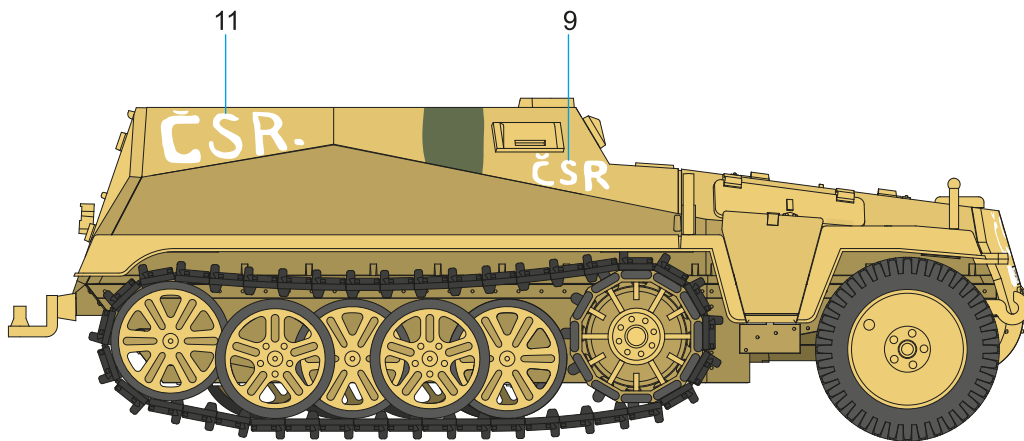
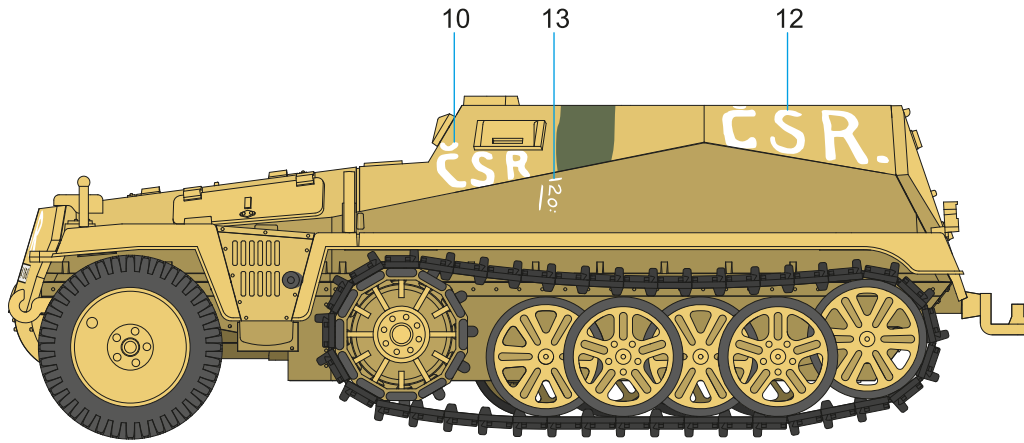

●  
Tmavá žlutá  
Dark Yellow  
RAL 7028  
H79 / C39

●  
Olivově zelená  
Olive Green  
H420 / C120

●  
Barva pneu  
Tyre Black  
H77 / C137

●  
Ocelová  
Steel  
H18 / C28

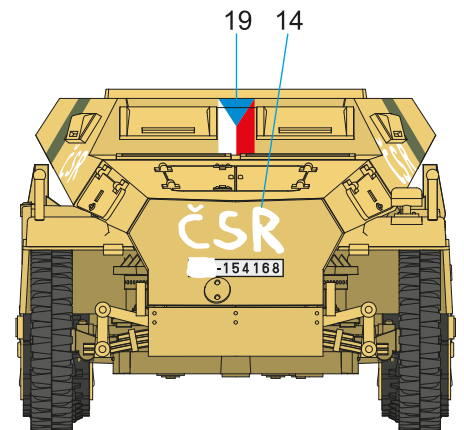



**Camo B**

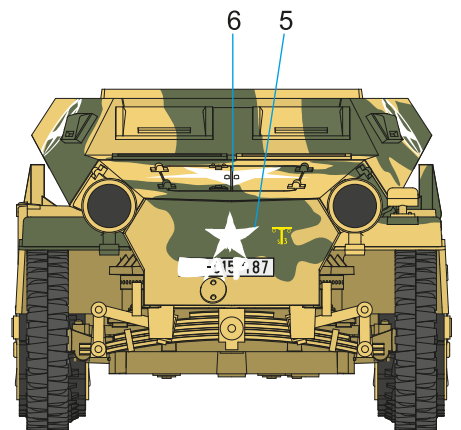
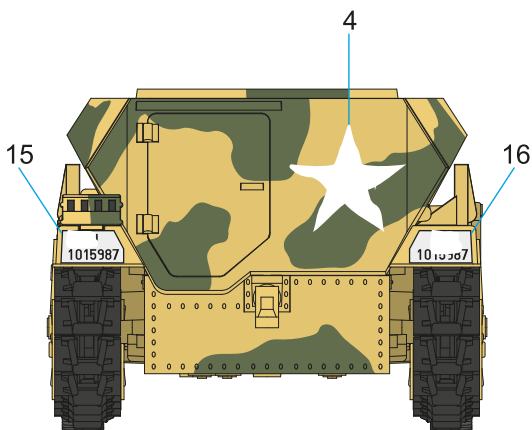
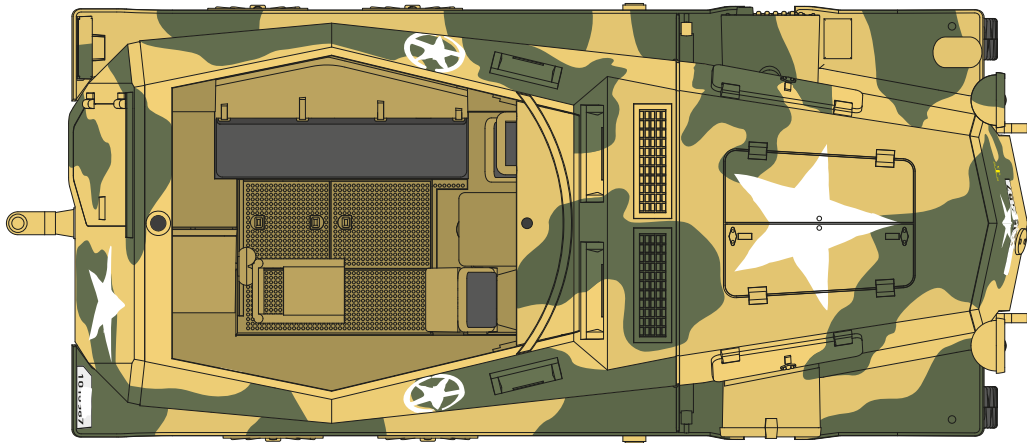
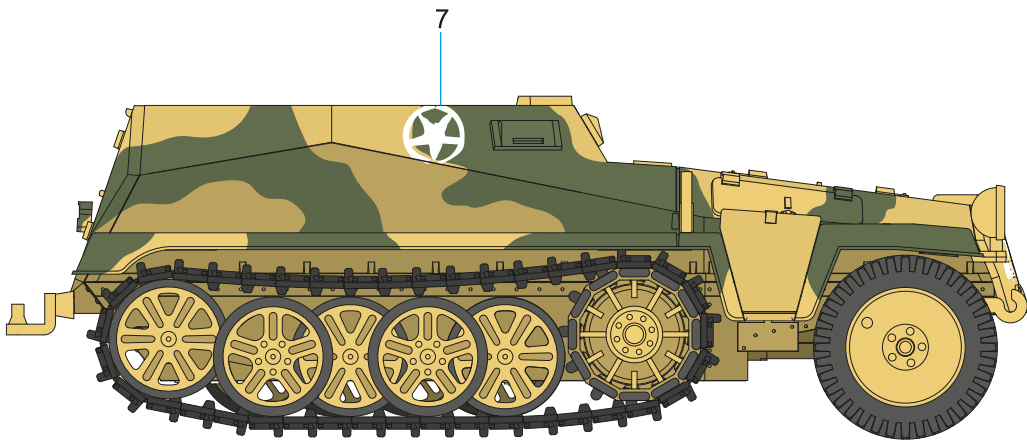
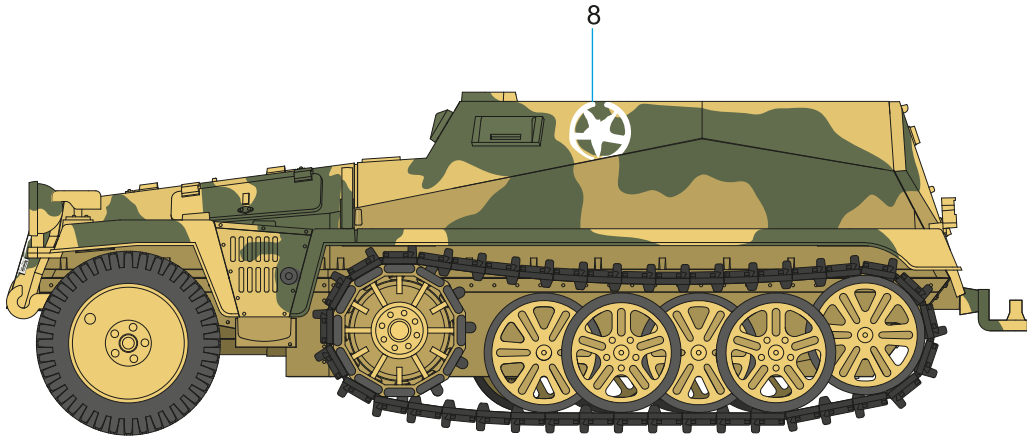

  
 Tmavá žlutá  
 Dark Yellow  
 RAL 7028  
 H79 / C39

  
 Olivově zelená  
 Olive Green  
 H420 / C120

  
 Barva pneu  
 Tyre Black  
 H77 / C137

  
 Ocelová  
 Steel  
 H18 / C28

**Camo C**

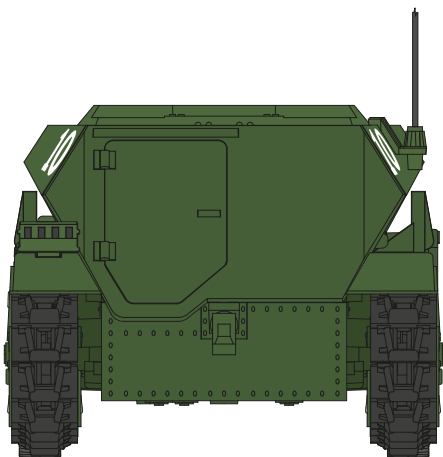
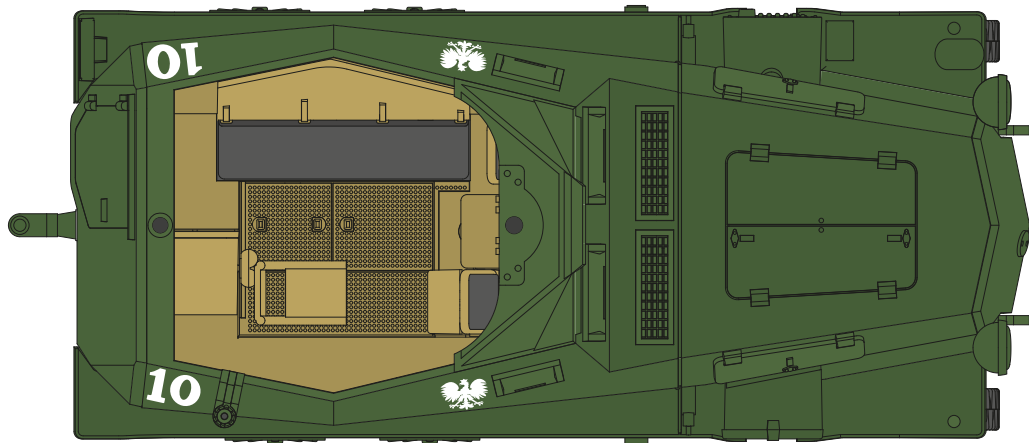
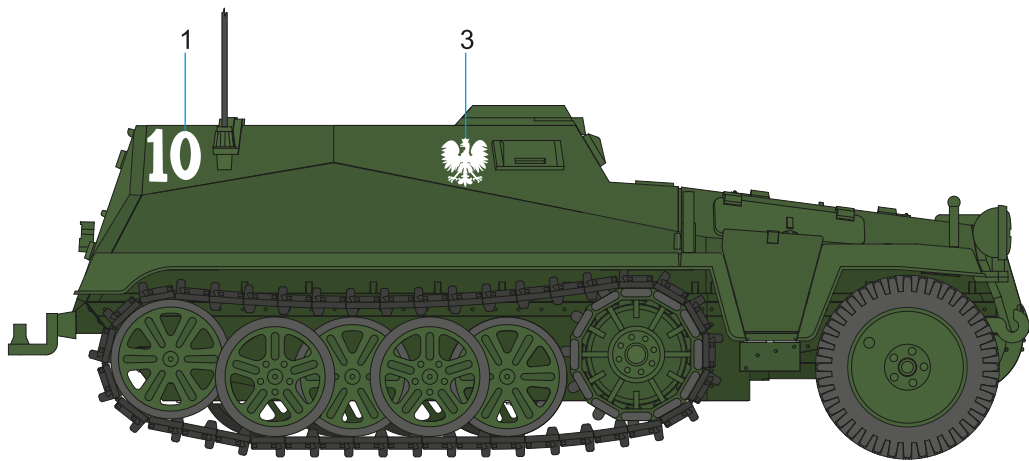
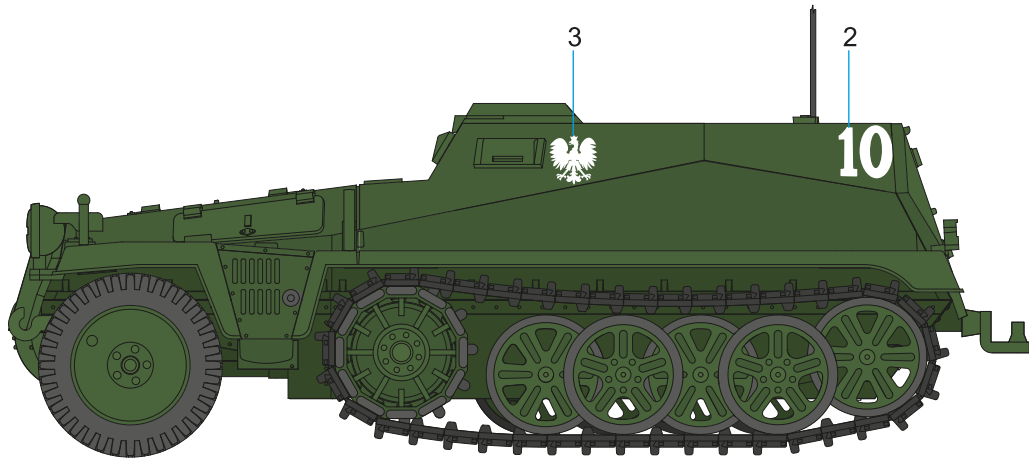

*Tmavá žlutá*  
Dark Yellow  
RAL 7028  
H79 / C39



*Ruská zelená*  
Russian Green  
H511 / C511



*Barva pneu*  
Tyre Black  
H77 / C137



*Ocelová*  
Steel  
H18 / C28

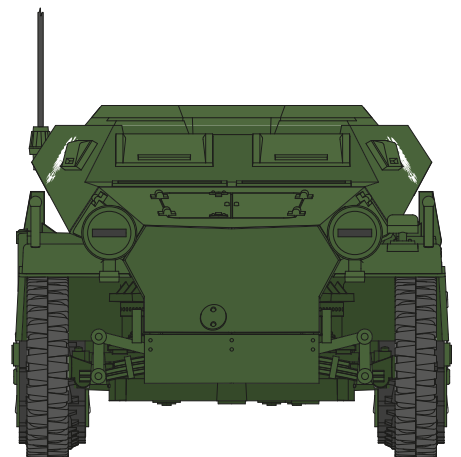

1/72 MV127



**Zetor 15**

'Czechoslovak Tractor'

ALL RESIN KIT

1/72 SA72022

**Sd.An 115 Flatbed Trailer**  
(Tank Transport)

PLASTIC KIT



1/72 B72104

Sd.An 115 Wheels

Special  
**ARMOUR**

RESIN  
SETS

1/72 SA72019

Special  
**ARMOUR**



**Sd.Kfz 250/1 Ausf.A**

(Alte Ausführung) PLASTIC KIT

1/72 SA72021

Special  
**ARMOUR**



**Sd.Kfz 10 Zugkraftwagen 1t**

(Demag D7) PLASTIC KIT



1/72 SA72001

**SS-100 Gigant Schwerer Radschlepper / Heavy Tractor**

Special  
**ARMOUR**



1/72 SA72012

**Meillerwagen "V-2 Transporter"**

Special  
**ARMOUR**



1/72 B72100

**Meillerwagen**

**"V-2 Transporter" Wheels Set**  
for Special Armour kit



1/72 B72094

**SS-100 Gigant Wheels**

for Special Armour kit



1/72 B72102

**Biber Trailer Wheels**

for Special Armour kit

Special  
**HOBBY**



facebook.com/specialhobby

[WWW.CMKKITS.COM](http://WWW.CMKKITS.COM) | [WWW.SPECIALHOBBY.EU](http://WWW.SPECIALHOBBY.EU)



**SA72020**

**Sd.Kfz 131**

**Marder II**

**7,5 cm PaK 40/2**

**PLASTIC KIT**



**B72103**

**Sd.Kfz 131 Marder II**

**EQUIPMENT**

**CMK RESIN SETS**



**SA72021**

**Sd.Kfz 10**

**Zugkraftwagen 1t**

**(Demag D7)**

**PLASTIC KIT**

**SA72018**

**BIBER**

**TRAILER**

**PLASTIC KIT**

