

Breda Ba.88B Lince 'Duce's Bomber'



Italské letectvo s plnou podporou Mussoliniho fašistů zahájilo ve třicátých letech minulého století úspěšný růst. Kvantitativní i kvalitativní růst letecké techniky se projevil i v počtu rekordů dosažených italskými stroji. Rekordy na vzdálenosti 500 a 1000 km s nákladem 500 a 1000 kg držel italský třímotorový stroj SM.79P. V dubnu 1937 však palmu vítězství na sebe strhnul prototyp Breda Ba.88 Lince pilotovaný továrním pilotem Furiou Niclotem Dogliou. V prosinci téhož roku je navíc ještě zvýšil (rychlost 524 km/h na trati 1000 km s nákladem 1000 kg). Dvumotorový celokovový stroj s motory Isotta Fraschini K-14 a jednoduchou ocasní plochou byl zalétán v říjnu 1936 továrním pilotem Furiou Niclotem Dogliou. Při záletu se projevil potíže se stabilitou. Stejný pilot zalétl také výše zmíněné rekordy. Výkony stroje zaujaly samotného Duceho, který požadoval zavedení Bredy 88 do výzbroje Regia Aeronautica. Konstruktéři Antonio Parana a Giuseppe Panzeri museli ale tento rychlostní stroj zcela přepracovat. Prototyp vojenské verze MM302 měl nové dvojité ocasní plochy, pumovnici na 1000 kg pum, v přídě tři kulometry 12,7 mm a v prostoru střelce pohyblivý kulomet 7,7 mm. Ani důkladné přepracování neodstranilo potíže se stabilitou. V druhé fázi testů stroj MM302 havaroval. Při havárii zahynul major Borgogno. I přesto byla zahájena sériová výroba. Sériové stroje byly poháněny motory Piaggio P-XI RC-40. Na začátku války zaútočily novými Bredami vyzbrojené bitevní skupiny Regia Aeronautica na Korsiku, bojovaly v Libyi. Ovšem potíže při bojovém nasazení vedly k převedení strojů k plnění nebojových úkolů. Firma Augusta se pokusila odstranit potíže strojů Breda 88 montáží nového křídla s větším rozpětím. V roce 1942 postavila tři kusy nové verze Ba.88M poháněné motory Fiat A-74 RC-38, s aerodynamickými brzdami pod novým křídlem. Do výzbroje je dostala 103. Gruppo Tuffatori. 7.9.1943 padly na letišti Lonate Pozzolo do německých rukou.

Technická data: rozpětí : 15,60m, délka: 10,79 m, max. rychlost 490 km/h, výstup do 4000 m: 9 min., dostup: 8000 m, dolet 1640 km

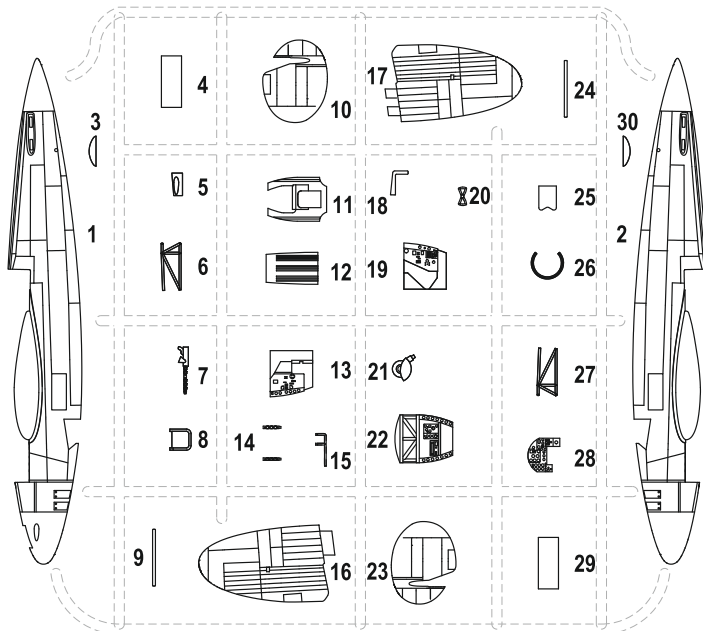

With full support of Mussolini's Fascist the Italian Air Force experienced successful growth during the 1930s. Both quantitative and quantitative growth of the aviation engineering also influenced the records that were achieved by Italian machines. The range record for 500 and 1000 km with 500 and 1000 kg payload was held by Italian tri-engine SM.79P. This record was in April 1937 broken by Breda Ba.88 Lince prototype flown by factory pilot Furia Niclote Doglia. Ba.88 even raised this record during December of the same year (speed of 524 kmh on 1000 km distance with 1000 kg payload). The all metal, twin-engine machine powered by Isotta Fraschini K-14 engines featured single tail fin. It took off for the first time in October 1936 with factory pilot Furia Niclote Doglia under controls. During this flight the stability issue appeared. The sole Duce himself was impressed by machine's performances and he insisted on equipping Regia Aeronautica with Breda 88. Both designers Antonio Parana and Giuseppes Panzeri had to completely redesign the speed racer. The prototype of the military version MM302 featured new, twin tail fin, bomb bay for up to 1000 kg payload, three fixed 12.7 mm machine guns in the nose and one flexible 7.7 mm machine gun in rear cockpit for defense. Even the redesigned structure didn't eliminate the stability issue. The MM302 prototype crashed during the second stage of the trials killing Maj Borgogno. Despite the above mentioned issues the mass production was started. The production machines were powered by Piaggio P-XI RC-40 engines. Regia Aeronautica's ground attack units equipped with new Bredas attacked Corsica and fought in Libya at the beginning of the war new. Nevertheless, the combat experiences led the Bredas to be assigned to non-combat duties. Augusta Company tried to eliminate the issues by installing new wing with bigger span. Three machines of Ba. 88M powered by Fiat A-74 RC-30 and with new speed brakes on the lower side of the wing were manufactured in 1942. They were assigned to 103. Gruppo Tuffatori. On September 7, 1943 were these machines seized by Germans at Lonate Pozzolo airfield. Wingspan: 15.60 m, Length: 10.79 m, Max. Speed 490 kmh, Climb to 4,000 m: 9 mins, Service Ceiling: 8,000 m, Range 1,640 km.

A

Barvy GUNZE/ GUNZE Colour No.

A	Černá/ BLACK	H12/C33
B	Pneu. šedá/ TIRE BLACK	H77/C137
C	Tmavý kov/ DARK IRON	MC214
D	Hliník/ ALUMINIUM	MC218
E	Ocel. šedá/ STEEL GREY	H75/C25
F	Opálený kov/ BURNT IRON	H76/C61
G	Interiér. zelená/ INTERIOR GREEN	H16/C64
H	Kůže/ LEATHER	H17/C29
I	Šedomodrá/ BLUE-GREY	H317 / C317

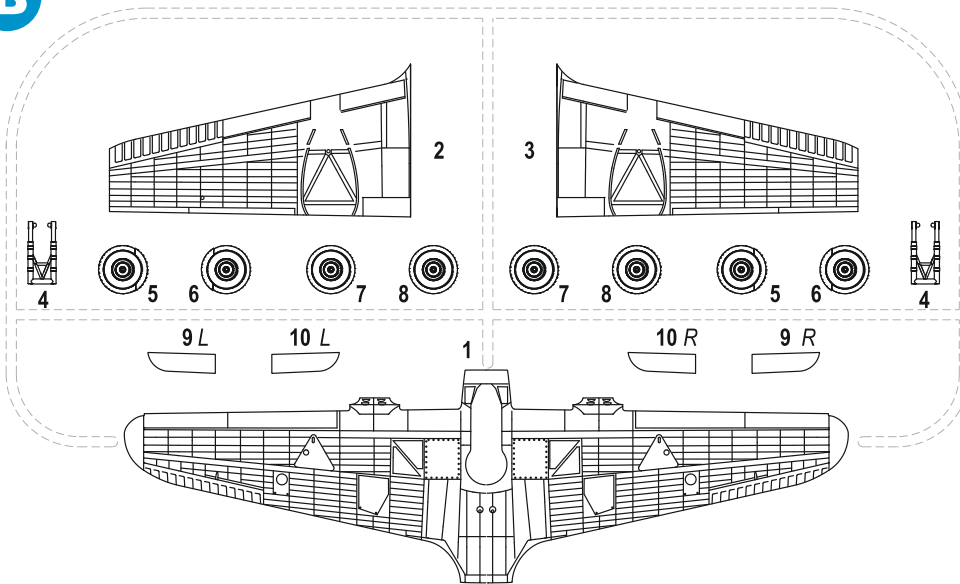
B

CLEAR PART (CP)

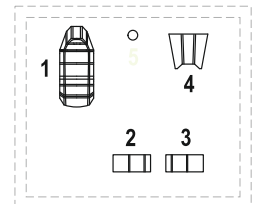
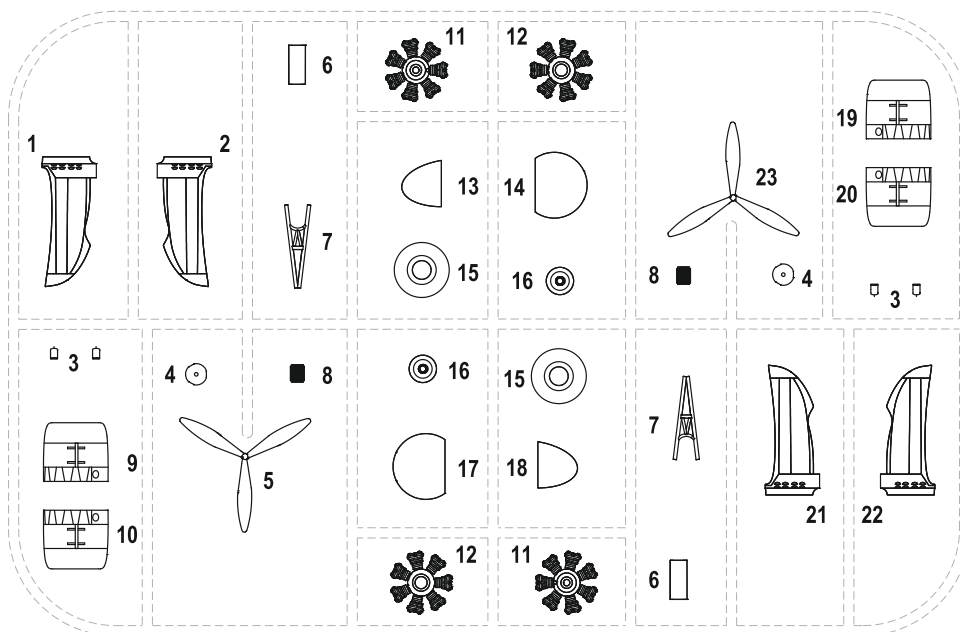
**C**

SYMBOLS



MOŽNOST VOLBY
OPTIONAL
NACH BELIEBEN
OPTION



POUŽIT KYANOAKRYLÁTOVÉ LEPIDLO
INSTANT CYANOACRYLATE GLUE
ZYANOAKRYLÁTKLEBER
ADHESIF CYANOACRYLAT



OHNOUT
BEND
BIEGEN
COURBER



ZHOTOVIT NOVÉ
SCRATCH BUILD
FERTIGSTELLEN
ACHEVER



ŘEZAT/VRTAT
CUT OFF/DRILL
ENTFERNEN
DETACHER

GSI **A**
colours code

NATRÍT
COLOUR
FARBEN
PEINDRE

1

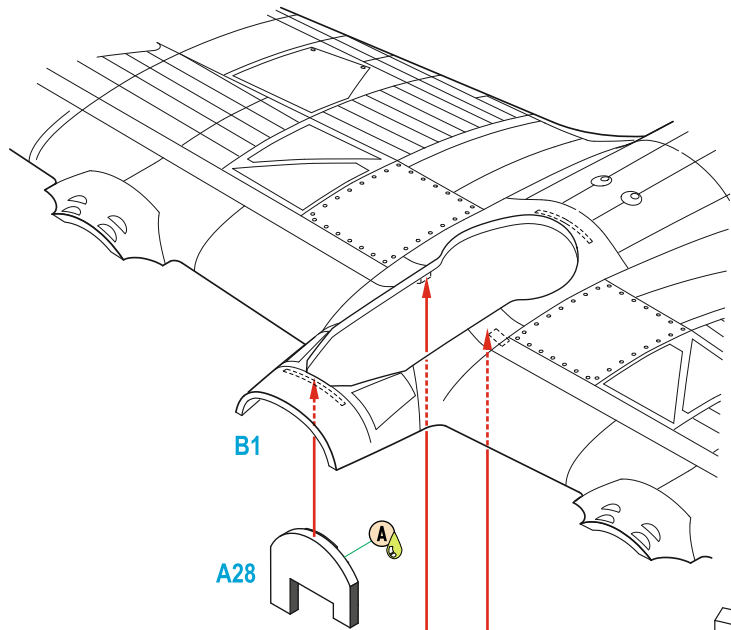
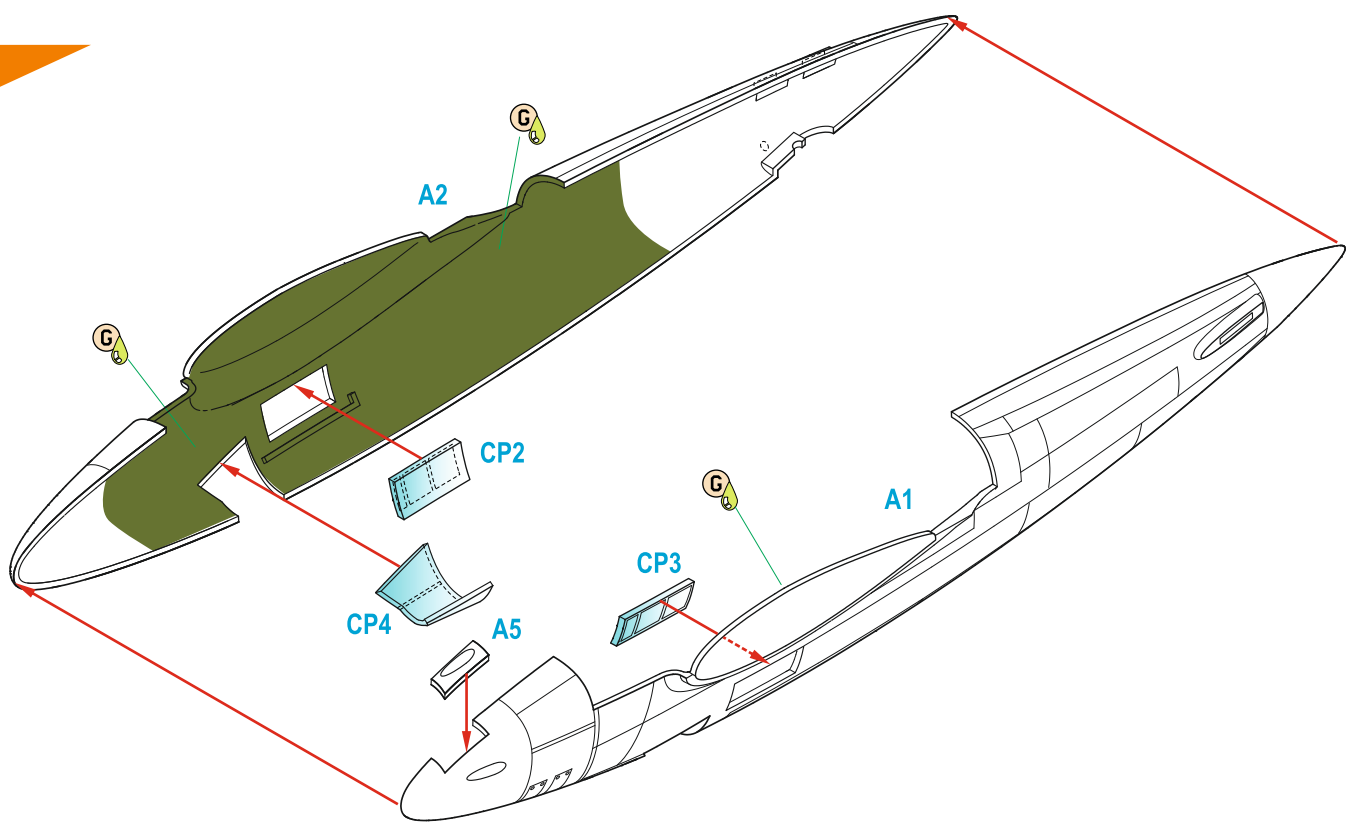

2a

2a

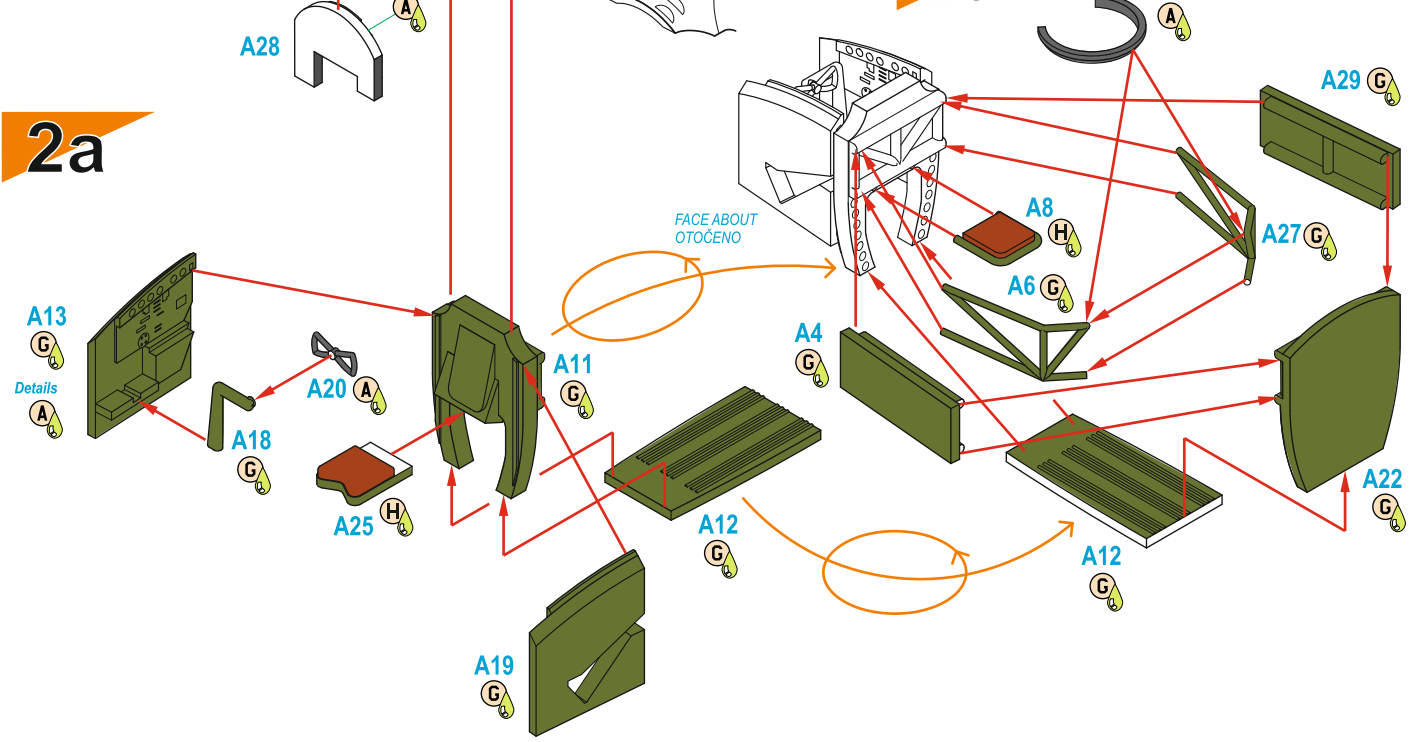

3

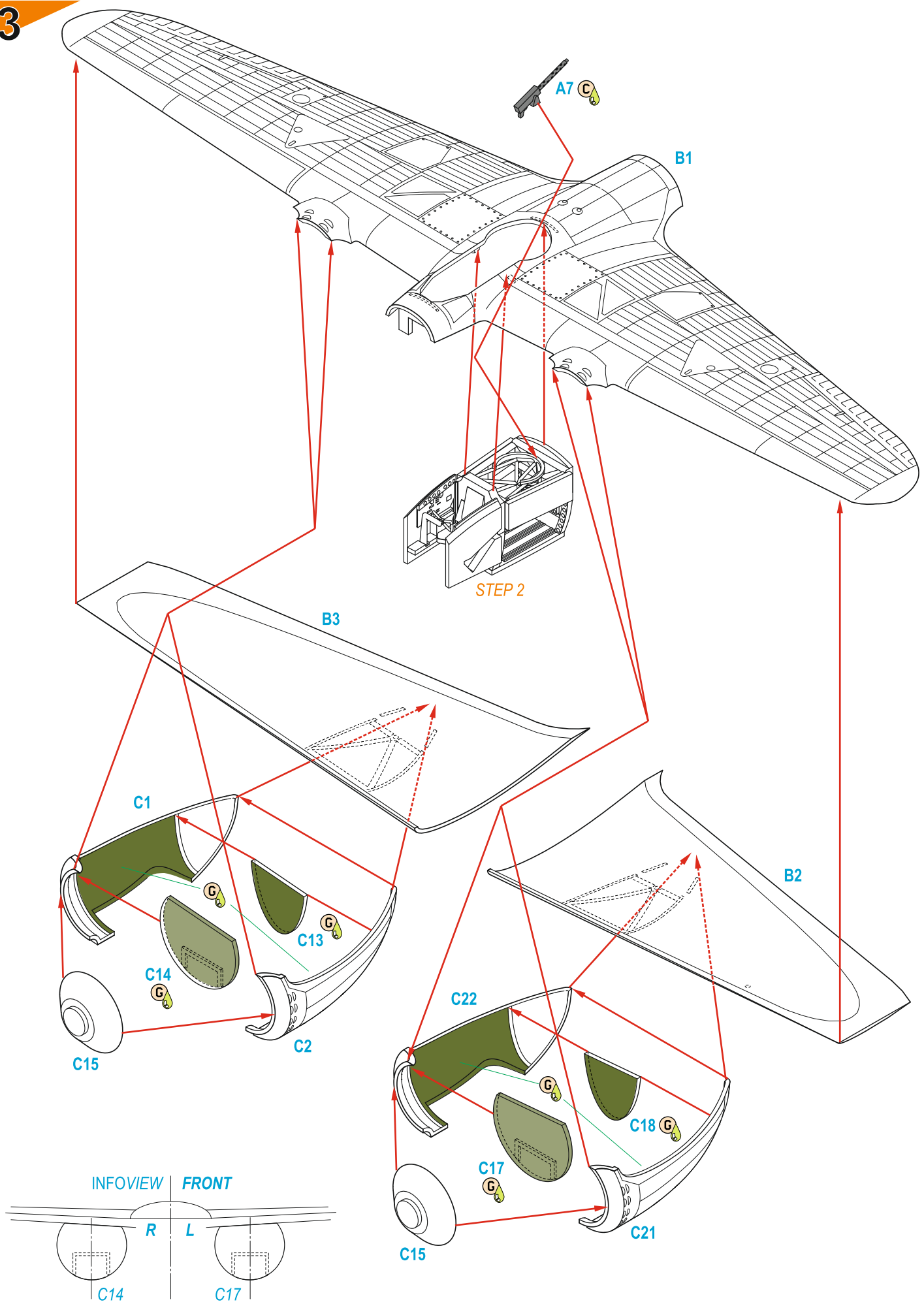

4

STEP 3

5

2x

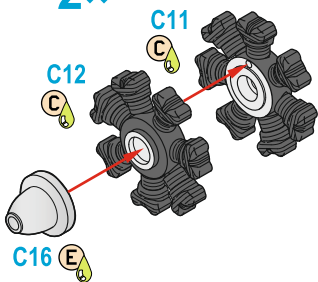

STEP 1

6

STEP 6

STEP 6

7

A17

A10

A16

A23

INFOVIEW

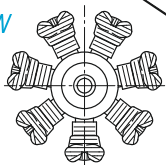

STEP 5

A14
A14

INFOVIEW

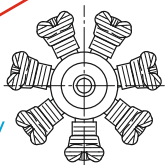

STEP 5

8

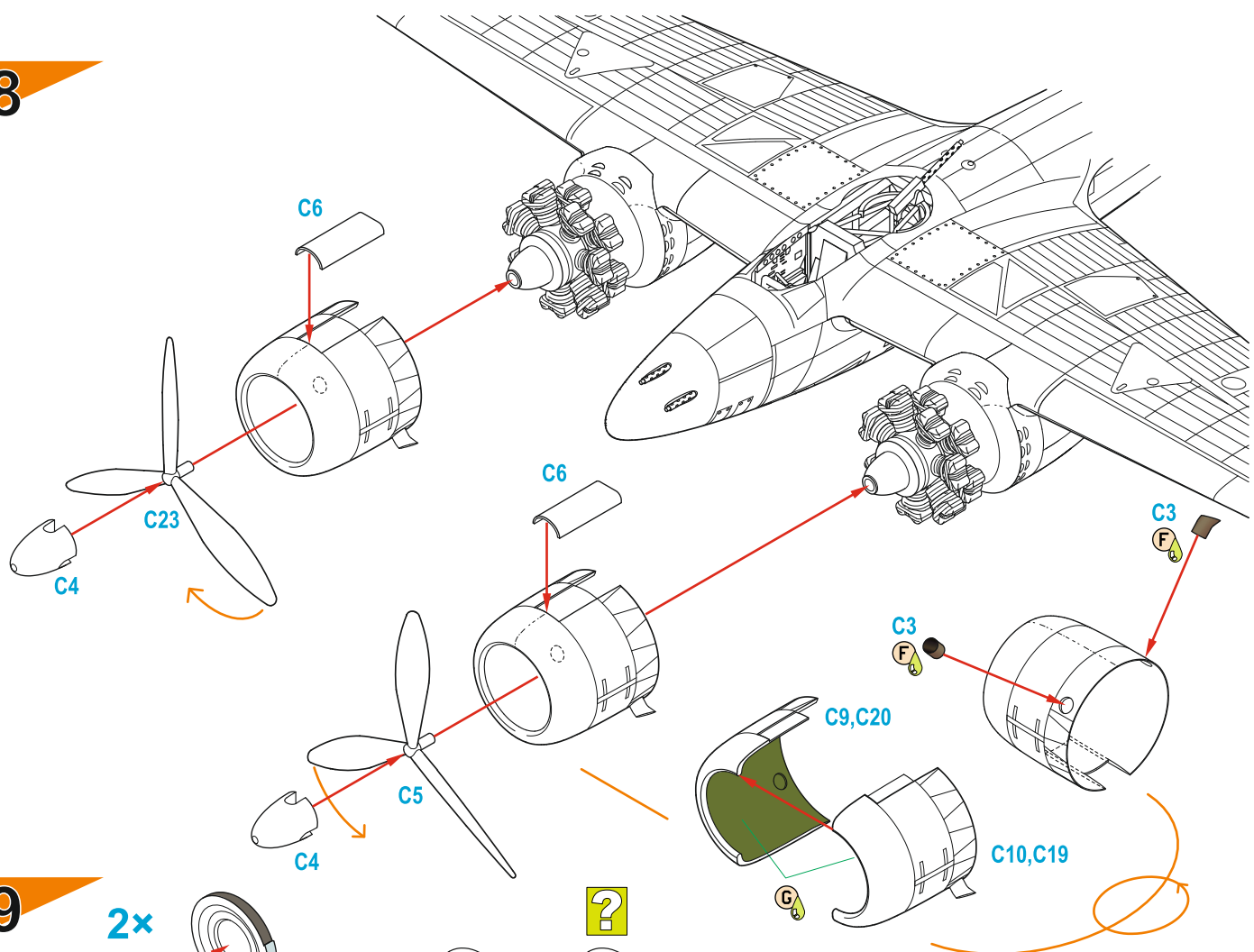

9

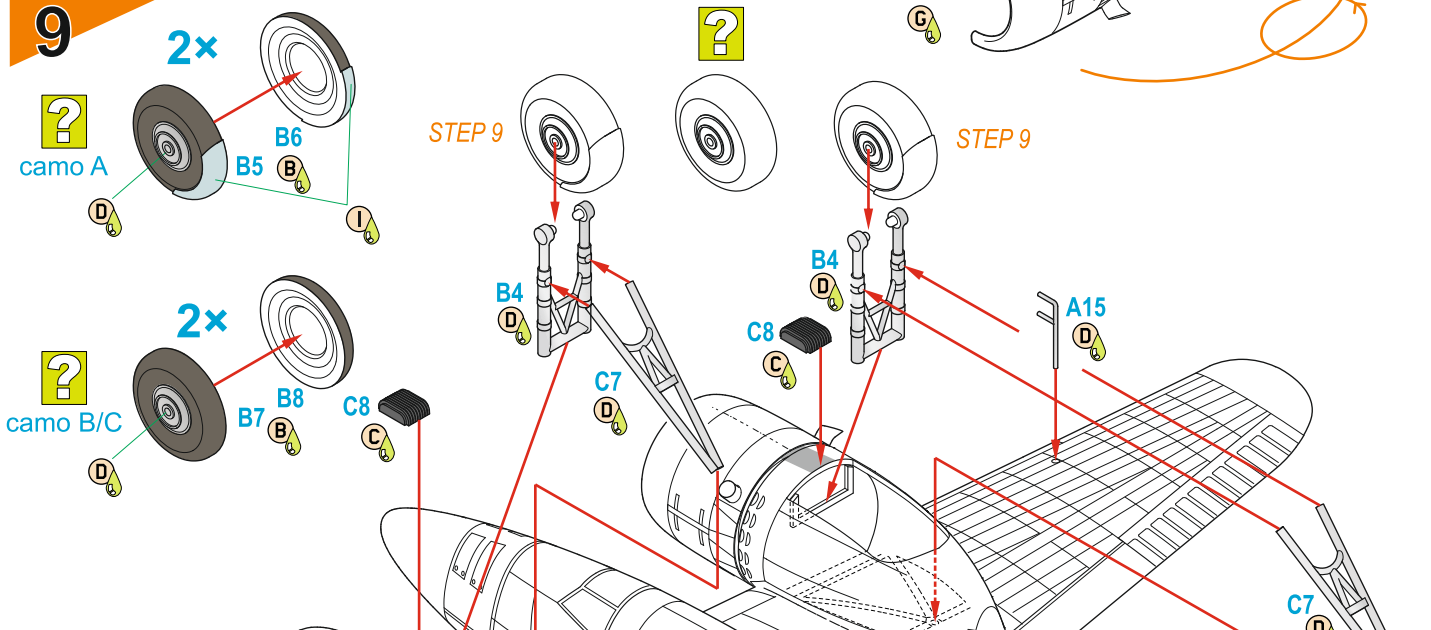

10

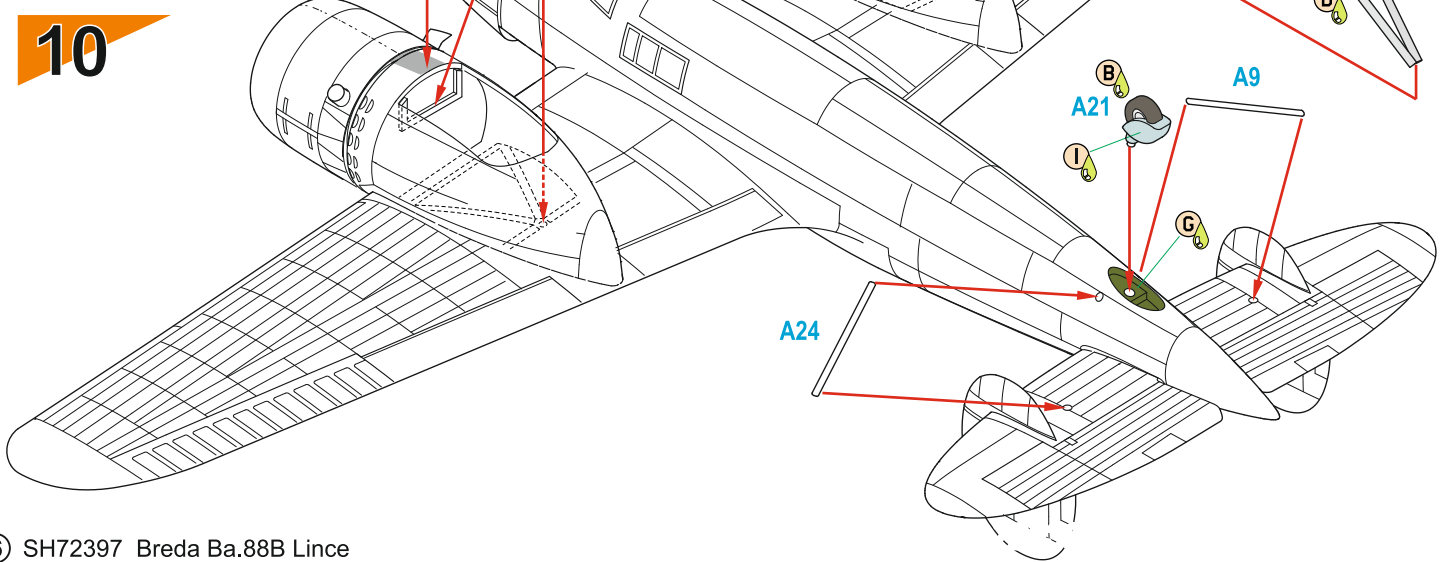

11

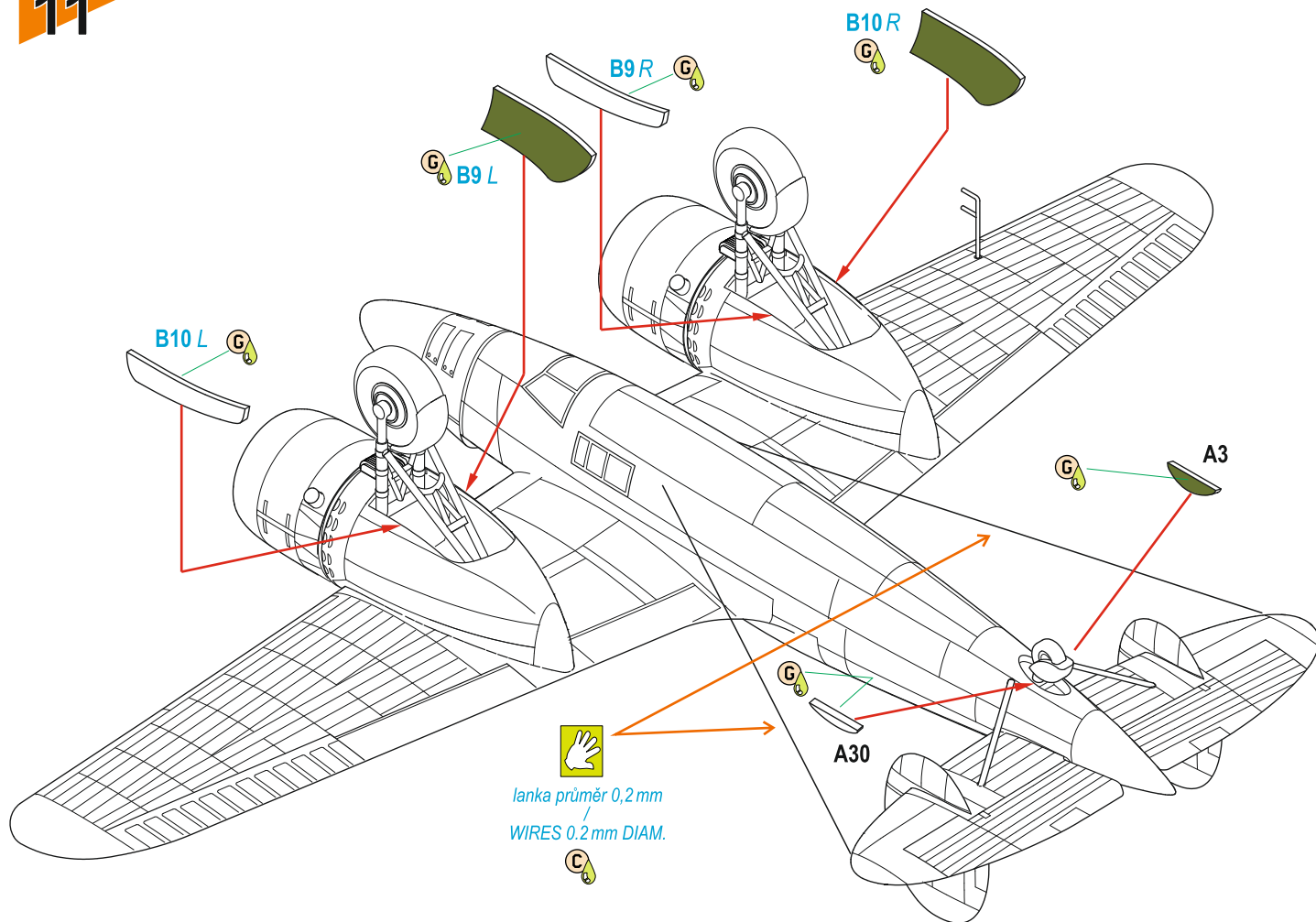

12

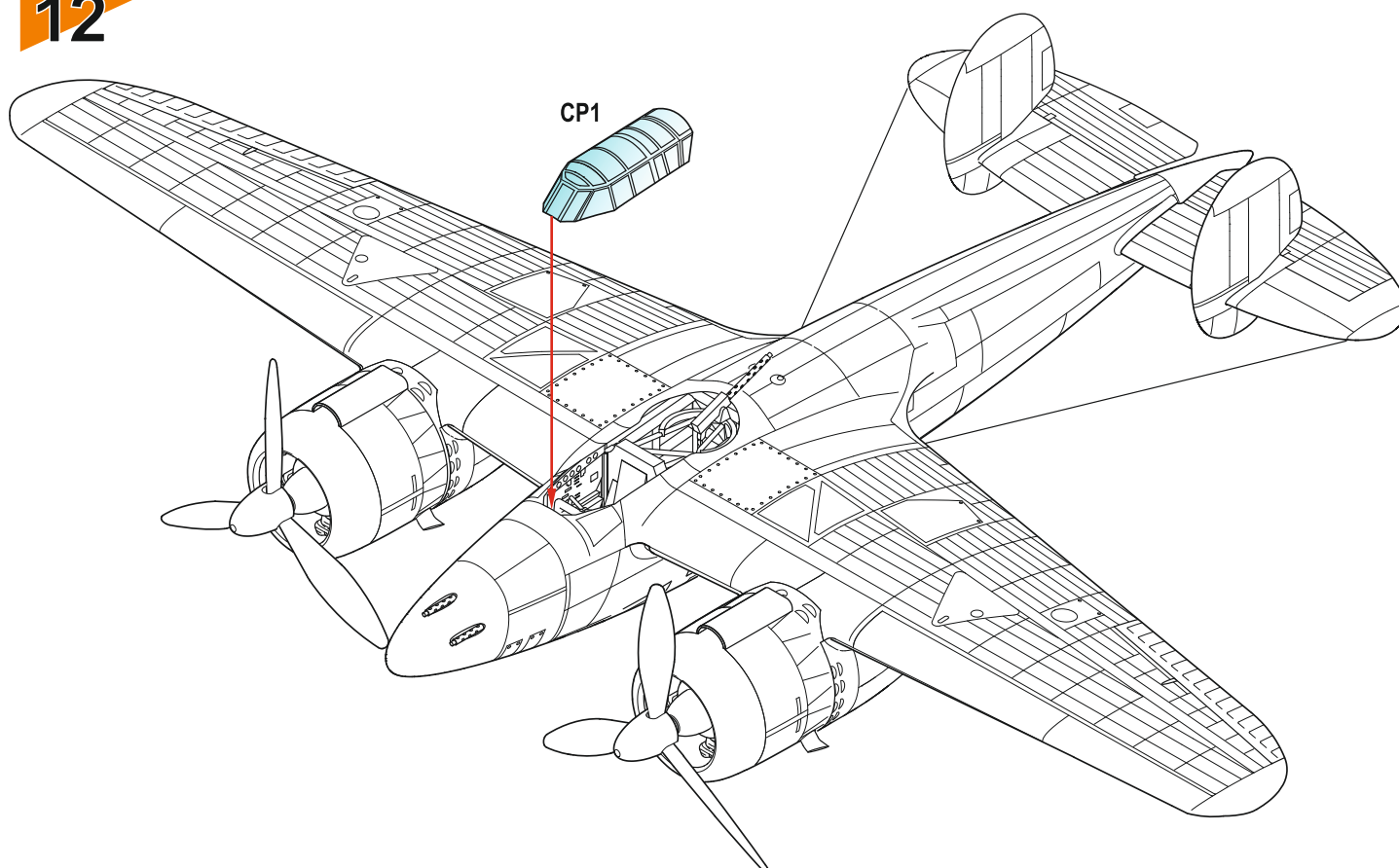

Breda Ba.88B Lince, 100-4, 100a Squadriglia, 7 Gruppo, based at Campiglia Marittima, Livorno, 1940.

Breda Ba.88B Lince, 100-4, 100a Squadriglia, 7 Gruppo, základna Campiglia Marittima, Livorno, 1940.

CAM. A

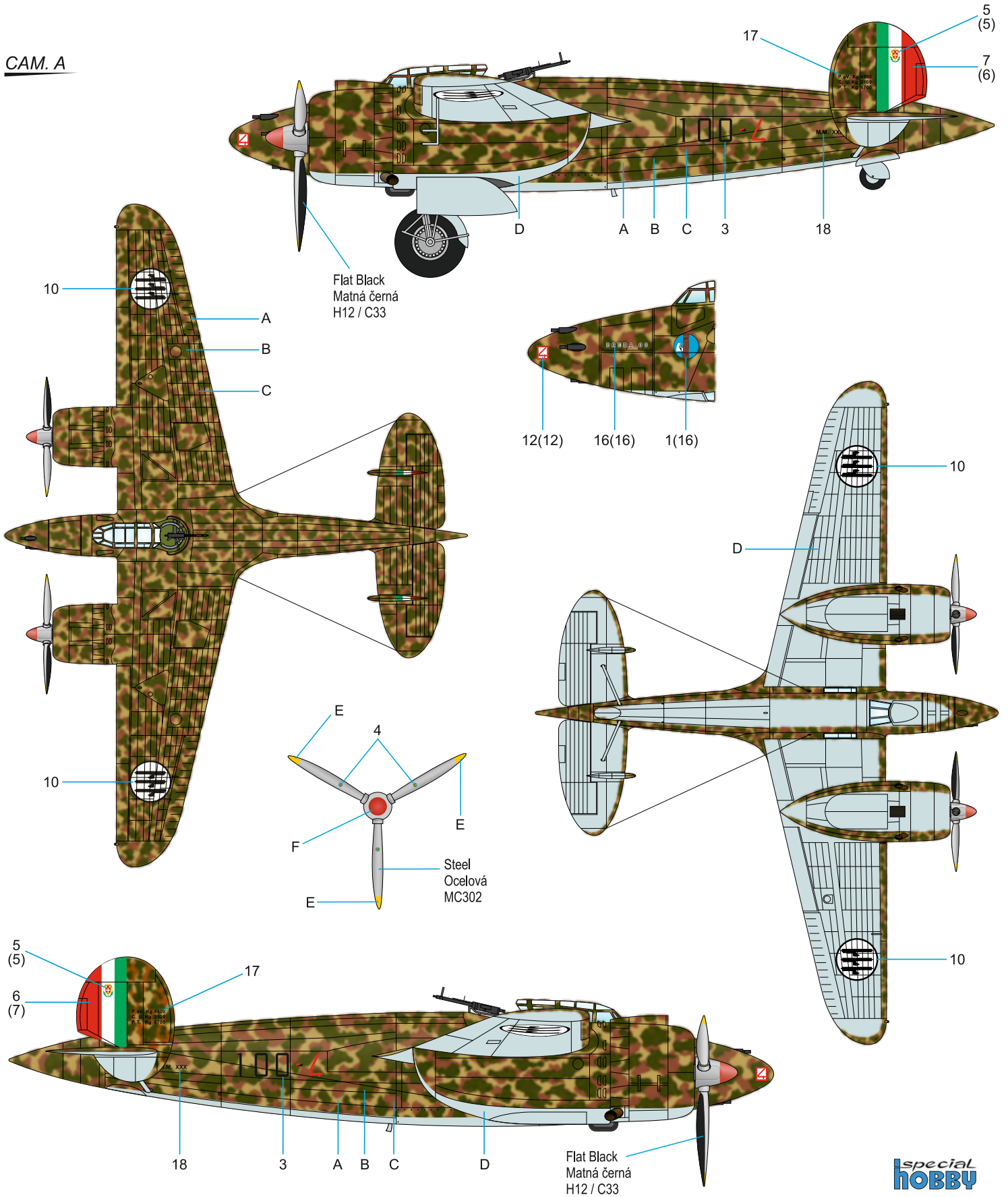

- | | | | | | |
|---|--|--|--|--|---|
| <p>A Giallo Mimetic 2
Sandy Yellow
Pískově žlutá
H79 / C39</p> | <p>B Verde Oliva Scuro 2
Olive Green
Olivově zelená
H302 / C302</p> | <p>C Marrone Mimetic 2
Red Brown
Hnědočervená
H47 / C41</p> | <p>D Grigio Mimetic
Blue-grey
Šedomodrá
H317 / C317</p> | <p>E Giallo Chromo 7
Yellow
Žlutá
H329 / C329</p> | <p>F Rosso
Red
Červená
H3 / C3</p> |
|---|--|--|--|--|---|



Breda Ba.88B Lince, 76-7, 76a Squadriglia, operated from Caselle Torinese, June, 1940.

Breda Ba.88B Lince, 76-7, 76a Squadriglia, základna Caselle Torinese, červen, 1940.

CAM. B

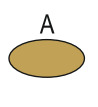
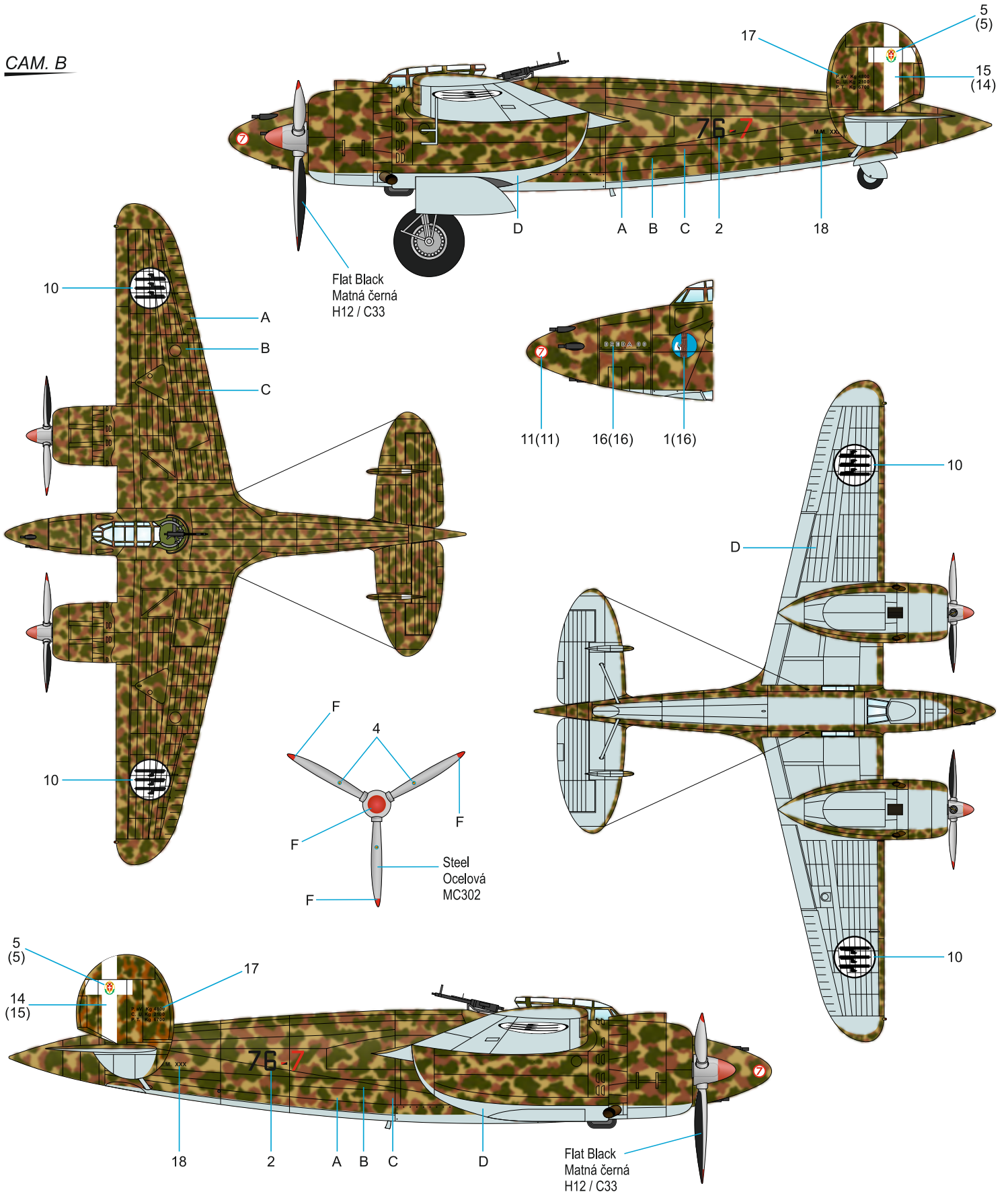

A Giallo Mimetico 2
Sandy Yellow
Pískově žlutá
H79 / C39



B Verde Oliva Scuro 2
Olive Green
Olivově zelená
H302 / C302



C Marrone Mimetico 2
Red Brown
Hnědočervená
H47 / C41



D Grigio Mimetico
Blue-grey
Šedomodrá
H317 / C317



F Rosso
Red
Červená
H3 / C3



Breda Ba.88B Lince, 76-6, 76a Squadriglia, North Africa, Autumn 1940.

Breda Ba.88B Lince, 76-6, 76a Squadriglia, Africe Settentrionale, severní Afrika, podzim 1940.

CAM. C

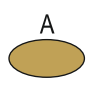
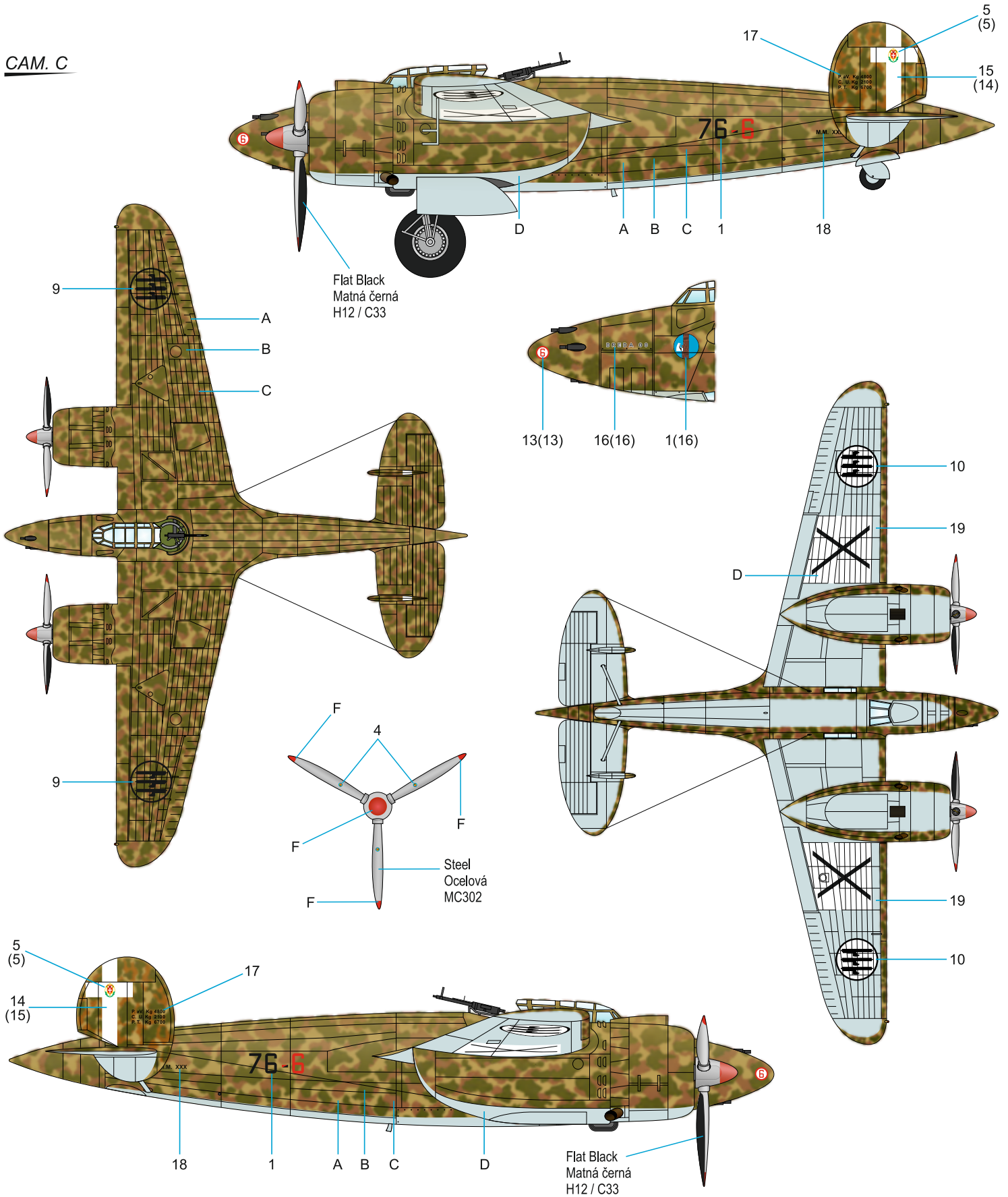

A Giallo Mimetico 2
Sandy Yellow
Pískově žlutá
H79 / C39



B Verde Oliva Scuro 2
Olive Green
Olivově zelená
H302 / C302



C Marrone Mimetico 2
Red Brown
Hnědočervená
H47 / C41



D Grigio Mimetico
Blue-grey
Šedomodrá
H317 / C317



F Rosso
Red
Červená
H3 / C3

