

EoN Eton TX.1 SG-38 Over Western Europe

EN

When the SG-38 elementary training glider was designed by Rehberg, Schneider and Hoffmann, its constructors could not have guessed just how famous it would become. This glider very soon became a standard training machine for the NSFK which was mass produced by several factories and it could also be home-built from drawings sent by post. Production was not restricted solely to Germany either and the basic design went on to be built throughout the world, making it the most widely used training glider ever known. The type was built within most European countries under a variety of different designations and amongst them was Slovakia which began production during WW2 and in post war years they continued to be built for aeroclubs in Czechoslovakia as the SK-38 Komar (Gnat) where they were used alongside some original ex-German SG-38 aircraft.

Technical data:

Wingspan: 10,40 m, length: 6,28 m, empty weight: 100 kg, max. speed: 115 km/h, max. glide ratio: 10:1 at 52 km/h.

CZ

Když pánové Rehberg, Schneider a Hoffmann navrhli kluzák pro základní výcvik SG-38 Schulgleiter, jistě netušili, jak slavný letoun stvořili. Kluzák se totiž brzy stal standardním kluzákem pro NSFK a byl vyráběn jak amatérsky podle zasílaných plánů, tak sériově v několika továrnách. A to jak v Německu, tak i v jiných státech, např. za války na Slovensku. Dalo by se říci, že minimálně v Evropě ho snad postavili úplně všude. Stal se nejmasověji vyrobeným školním kluzákem světa. Po druhé světové válce byla vyrobena série SG-38 s označením ŠK-38 Komár i pro československé aerokluby. Tyto nově vyrobené kluzáky pak u nás sloužily společně s kořistními. Kořistní kluzáky používali po válce i v Polsku, Francii, a jinde v Evropě.

Technická data:

Rozpětí: 10,40 m, délka: 6,28 m, prázdná váha: 100 kg, max. rychlost: 115 km/h, max. klouzavost: 10:1 při 52 km/h.

Parts List

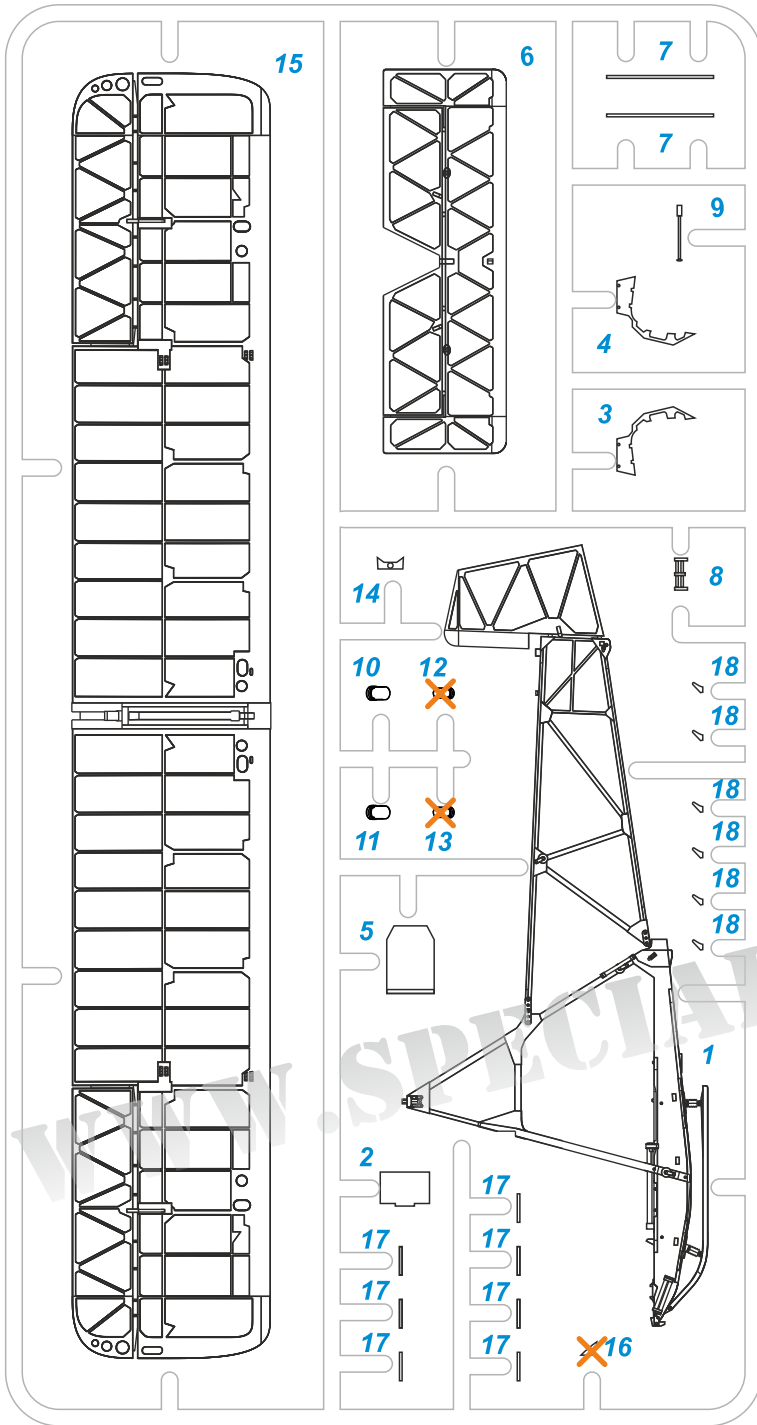
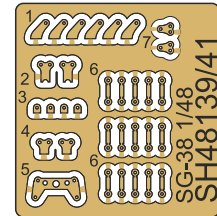



Photo Etched Parts (PE)



 = Do not use this part
Tento díl nepoužít

Barvy GUNZE/ GUNZE Colour No.

	Aluminium / hliník	H8/C8
	Tire Black / barva pneu	H77/C137
	Dark Metal / tmavý kov	MC214
	Varnished Wood / lakované dřevo	H66/C119
	Bleaded fabric / bělené plátno	H21/C69
	Yellow / žlutá	H329/C329
	Dark Green / tmavě zelená	H73/C70
	Dark Green / tmavě zelená	H320/C320

SYMBOLS



OPTIONAL
MOŽNOST VOLBY
NACH BELIEBEN
OPTION



INSTANT CYANOACRYLATE GLUE
POUŽÍT KYANOAKRYLÁTOVÉ LEPIDLO
ZYANOAKRYLATKLEBER
ADHÉSIF CYANOACRYLAT



BEND
OHNOUT
BIEGEN
COURBER



SCRATCH BUILD
ZHOTOVIT NOVÉ
FERTIGSTELLEN
ACHEVER



CUT OFF/DRILL
ŘEZAT/VRTAT
ENTFERNEN
DETACHER

GSI 
colours code

COLOUR
NATRÍT
FARBEN
PEINDRE

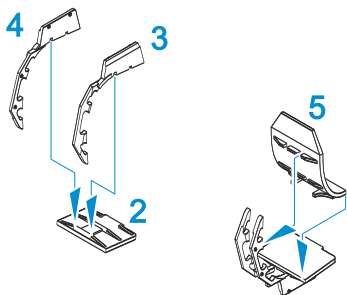
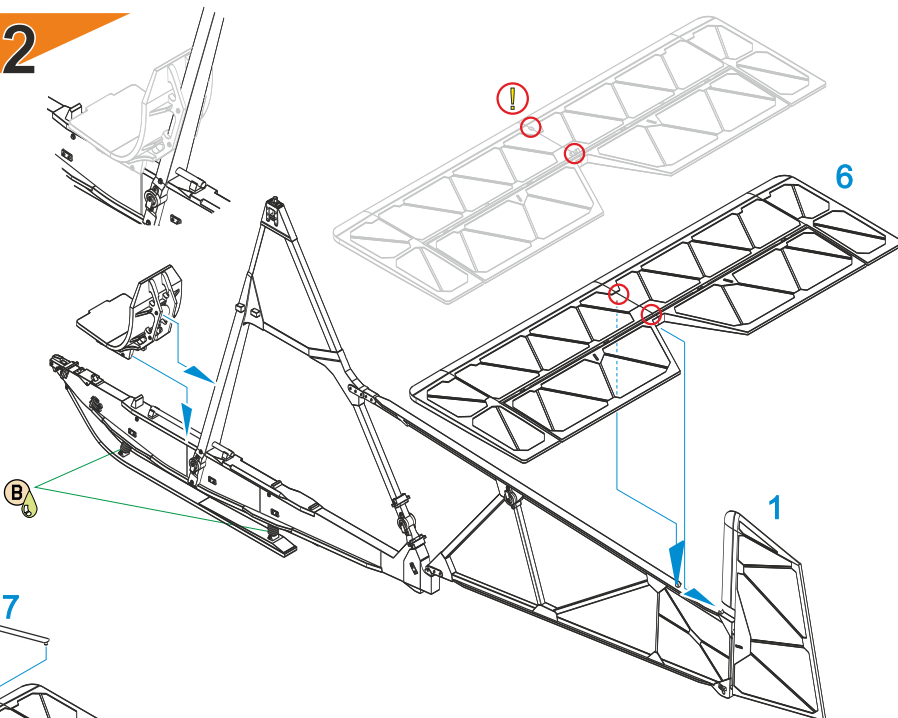
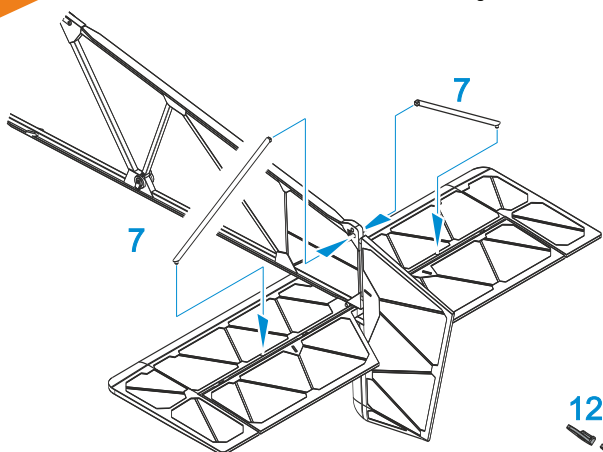
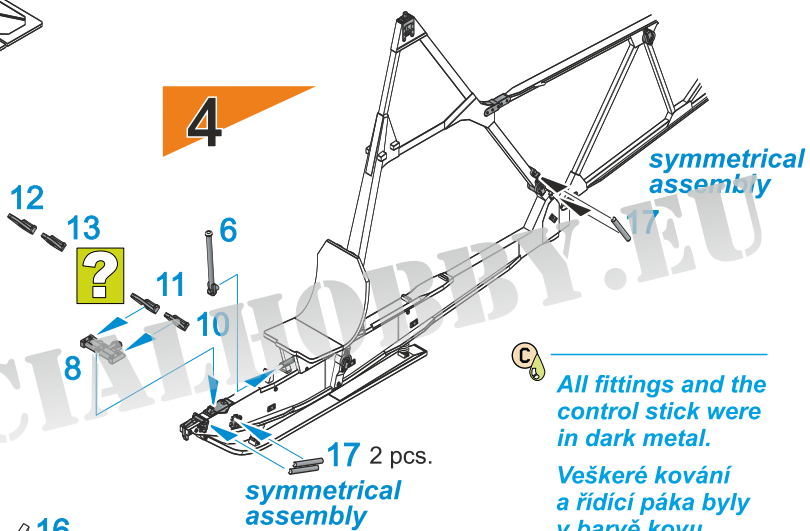
1**2****3****4**

C All fittings and the control stick were in dark metal.
 Veškeré kování a řídicí páka byly v barvě kovu.

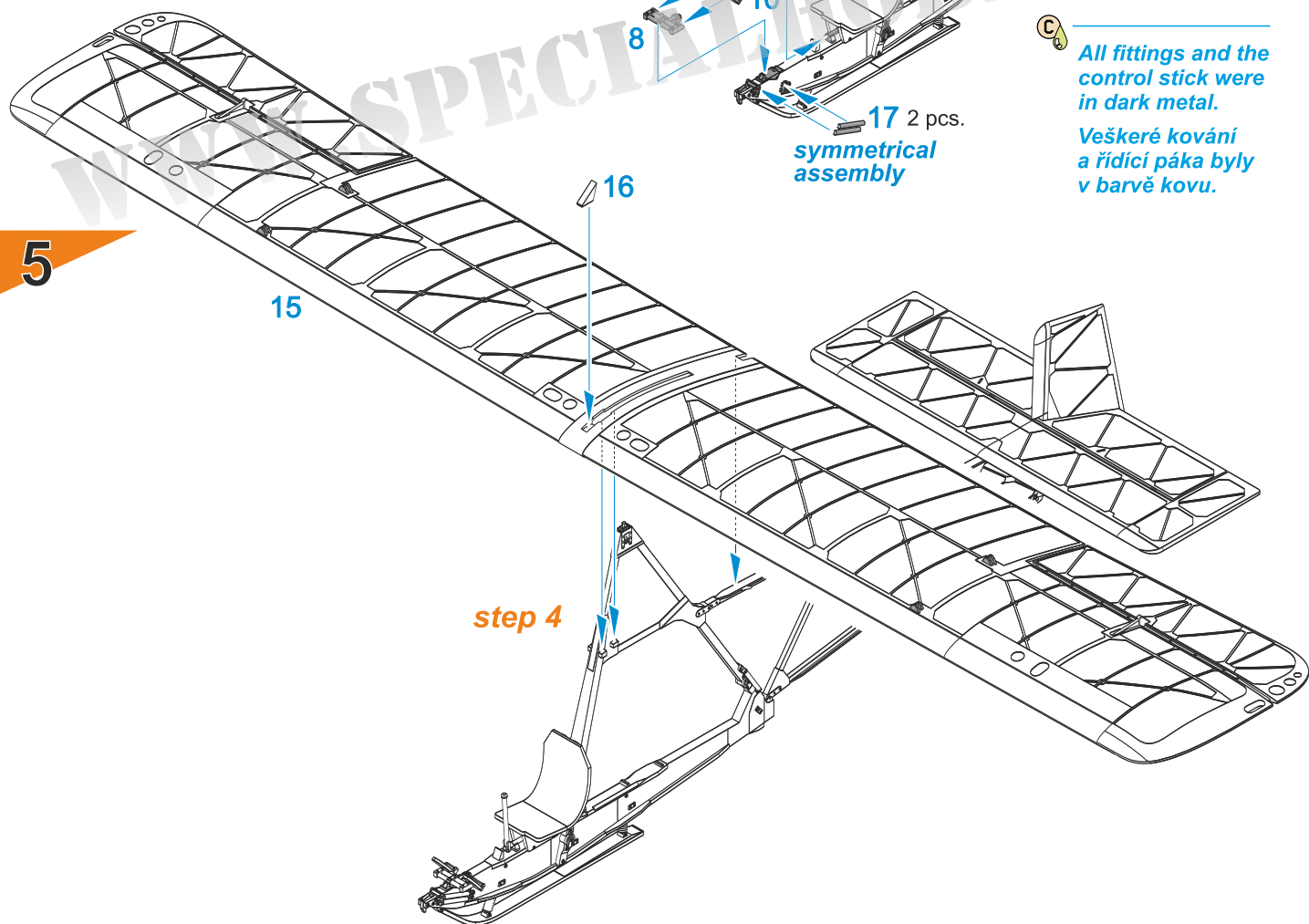
5

6

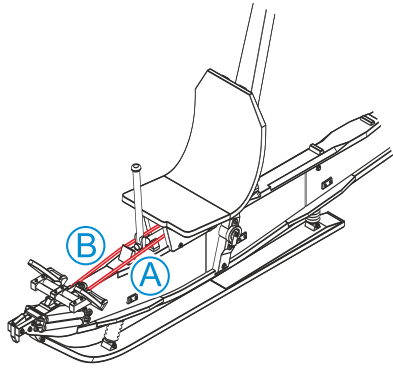

7

- wire A = 20 mm
- wire B = 20 mm
- wire C = 19 mm
- wire D = 93 mm
- wire E = 20 mm
- wire F = 24 mm
- wire G = 33 mm
- wire H = 23 mm
- wire I = 8 mm
- wire J = 30 mm

note:
all bracing wire lengths
are approximate only

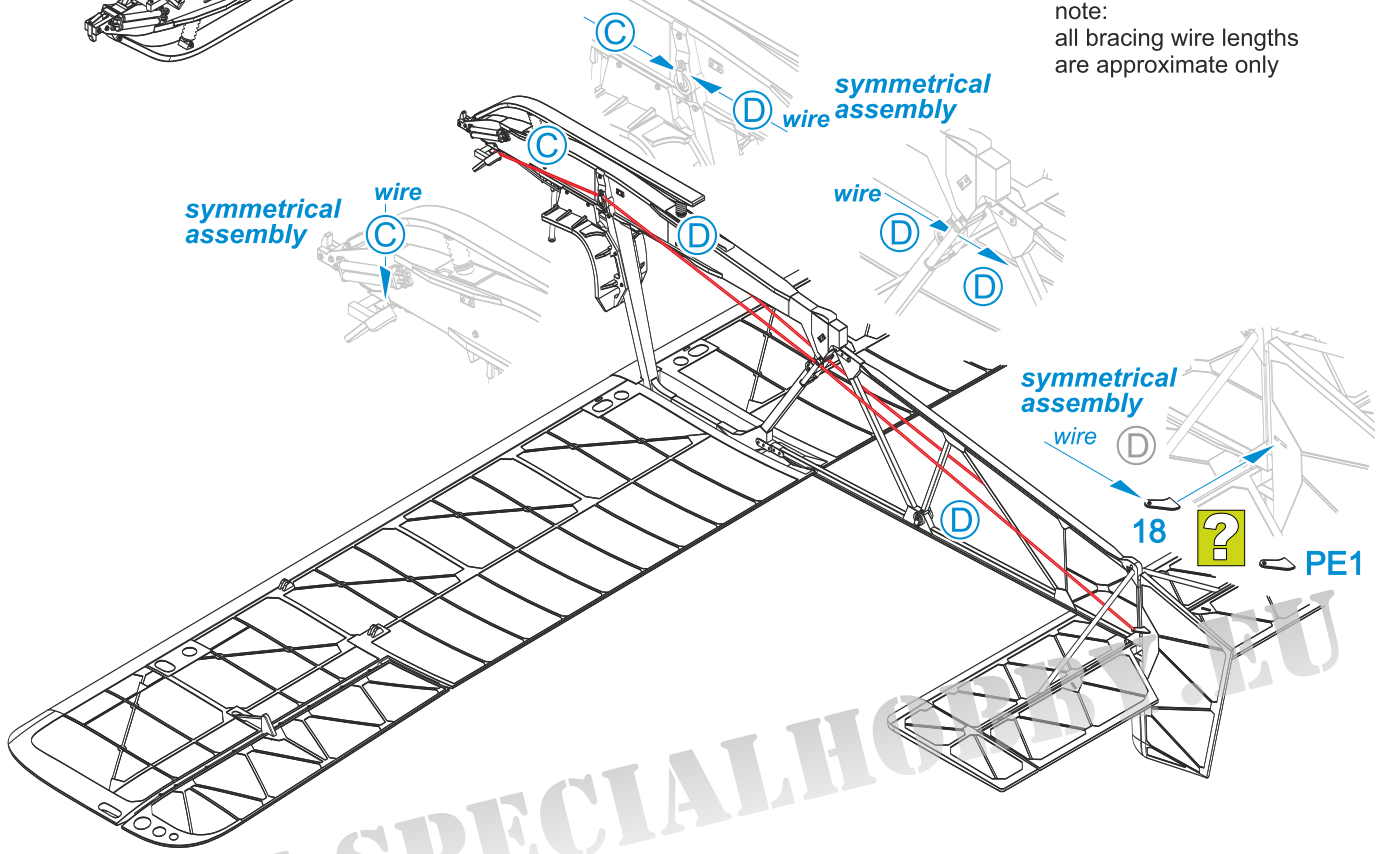

8

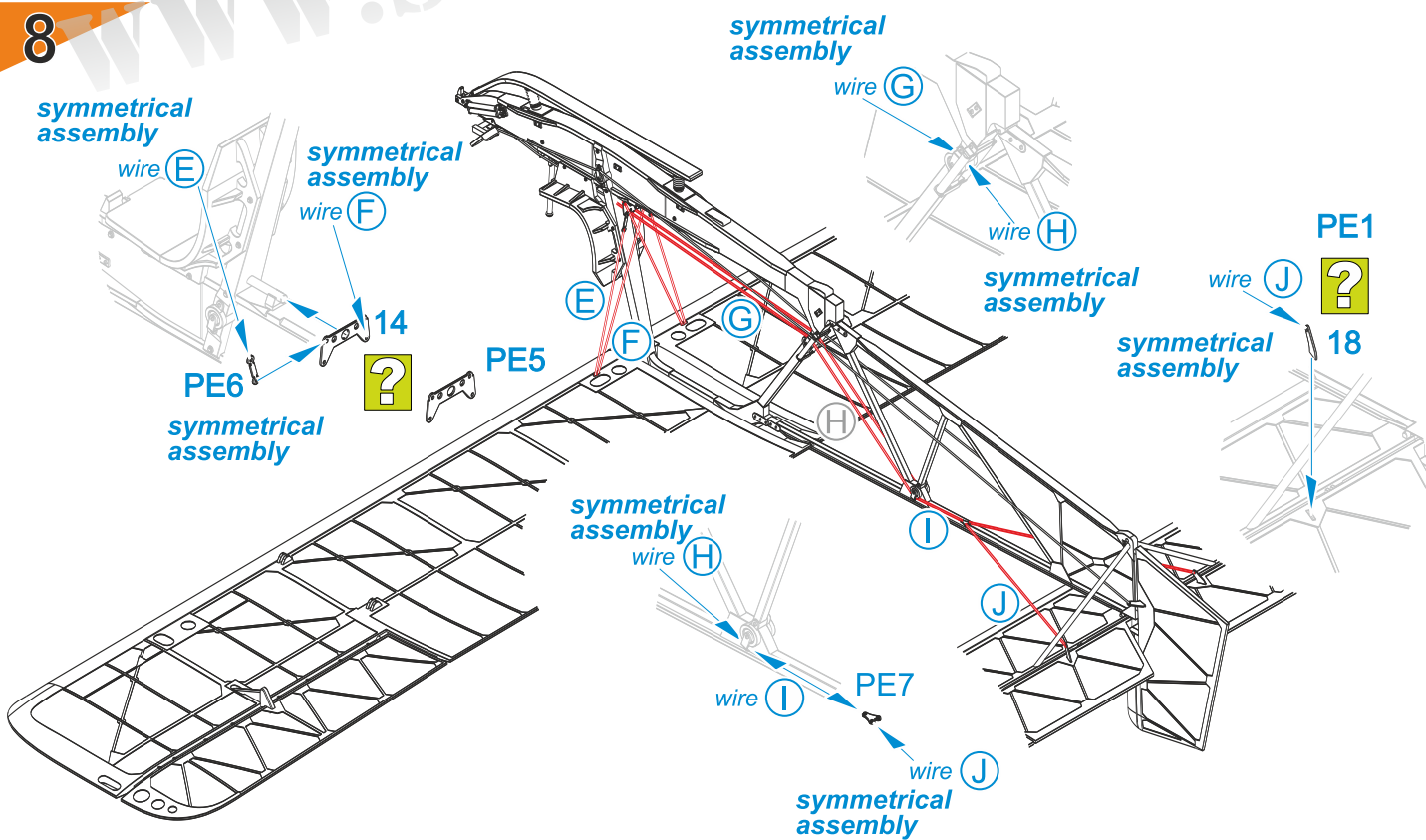

9

wire K = 59 mm
wire L = 59 mm
wire M = 13 mm
wire N = 25 mm

note:
all bracing wire lengths
are approximate only

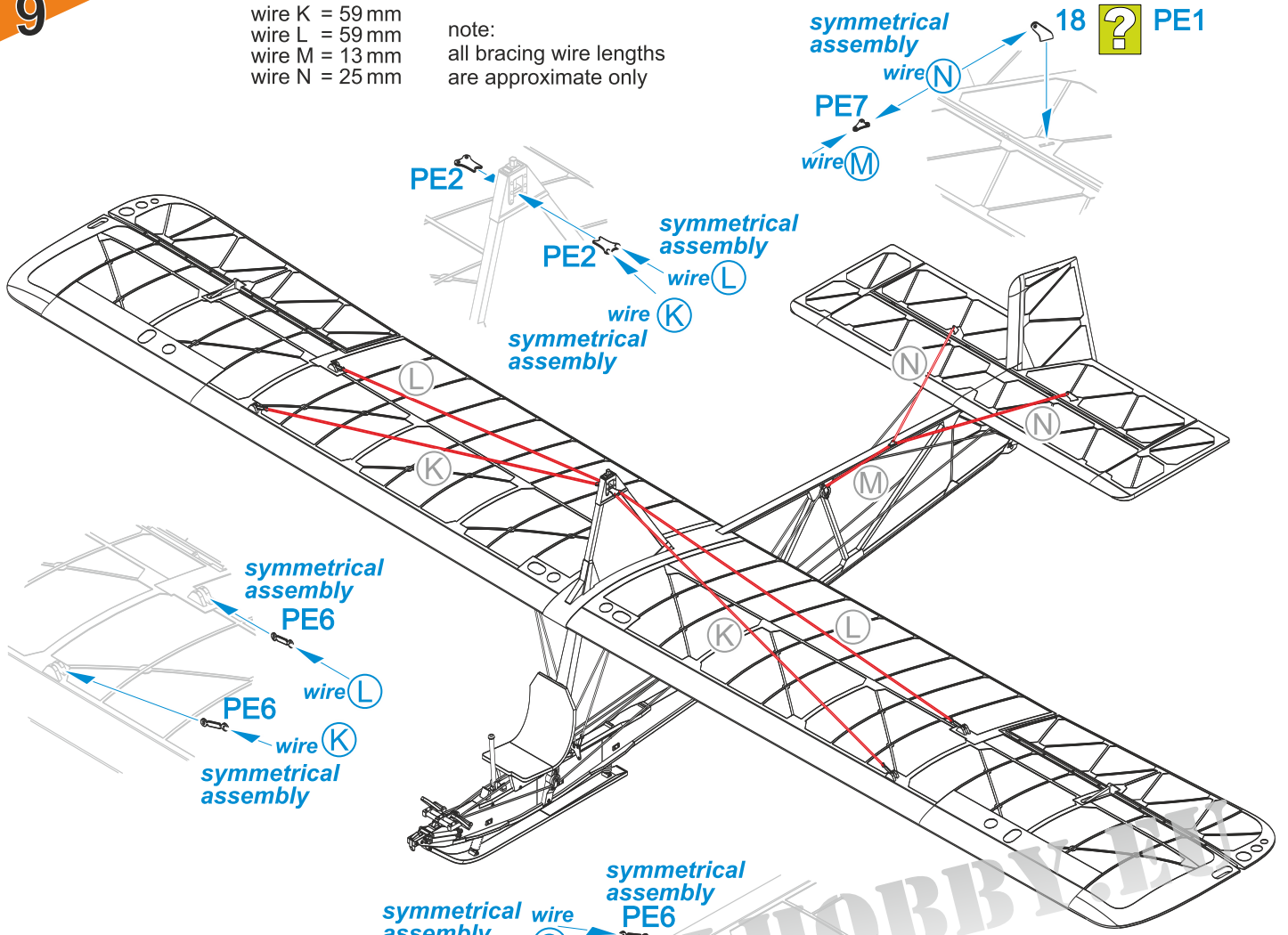

10

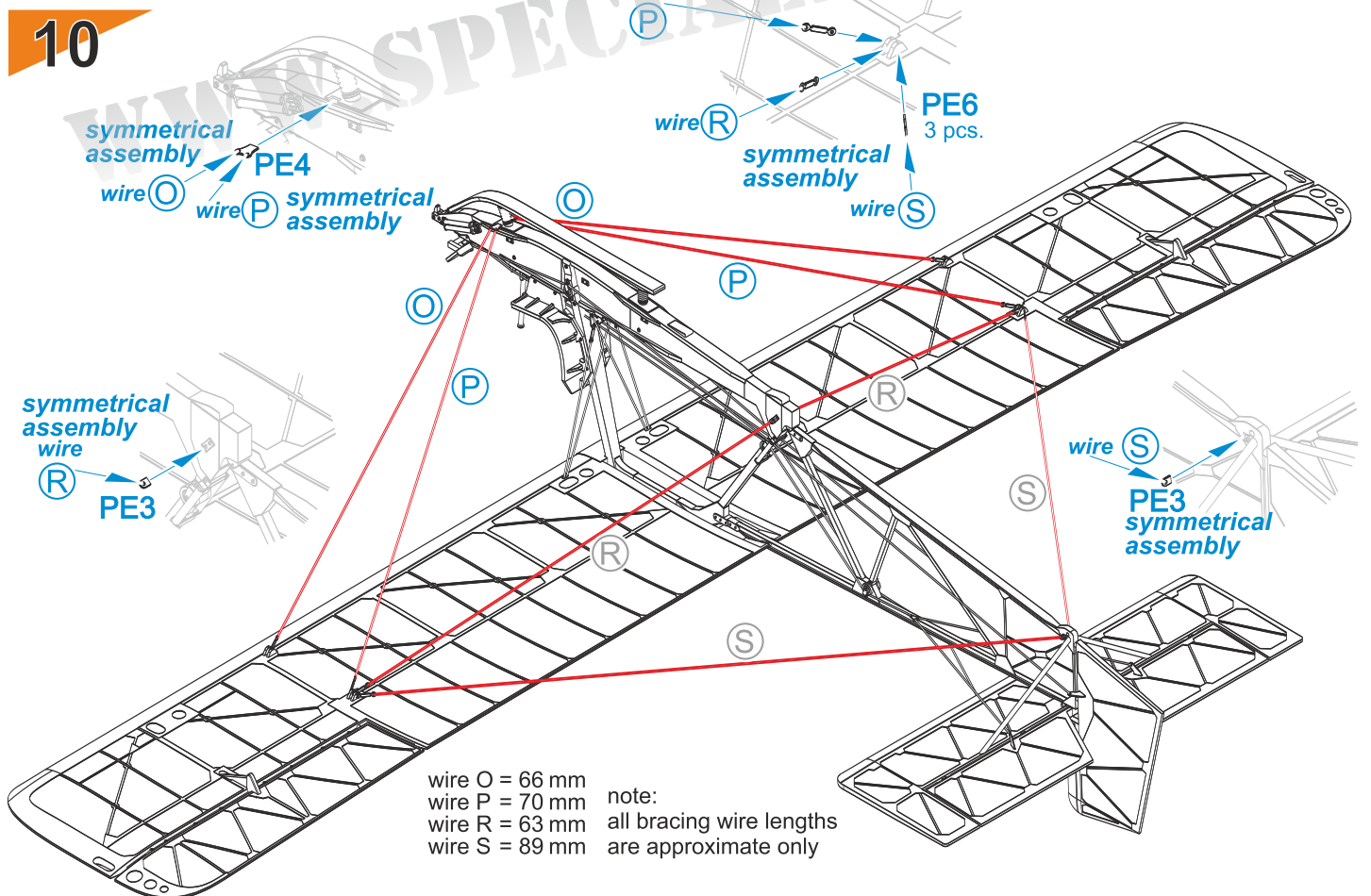

wire O = 66 mm
wire P = 70 mm
wire R = 63 mm
wire S = 89 mm

note:
all bracing wire lengths
are approximate only

Eon Eton TX.1, WP270, c/n 038, delivered to Maidstone Grammar School Combined Cadet Force (Air Cadets) in September 1951 where it was used until May 1961 and had accumulated 1183 launches. Its last flight took place on 12 July 1962 at RAF Bicester, since then on display at Hendon and Manchester museums.

Eon Eton TX.1, WP270, výrobní číslo 038, byl používán od září 1951 v Maidstone Grammar School Combined Cadet Force (Air Cadets). Bylo na něm provedeno 1183 letů, poslední 12. července 1962. Nyní je muzejním exponátem.

CAM. A

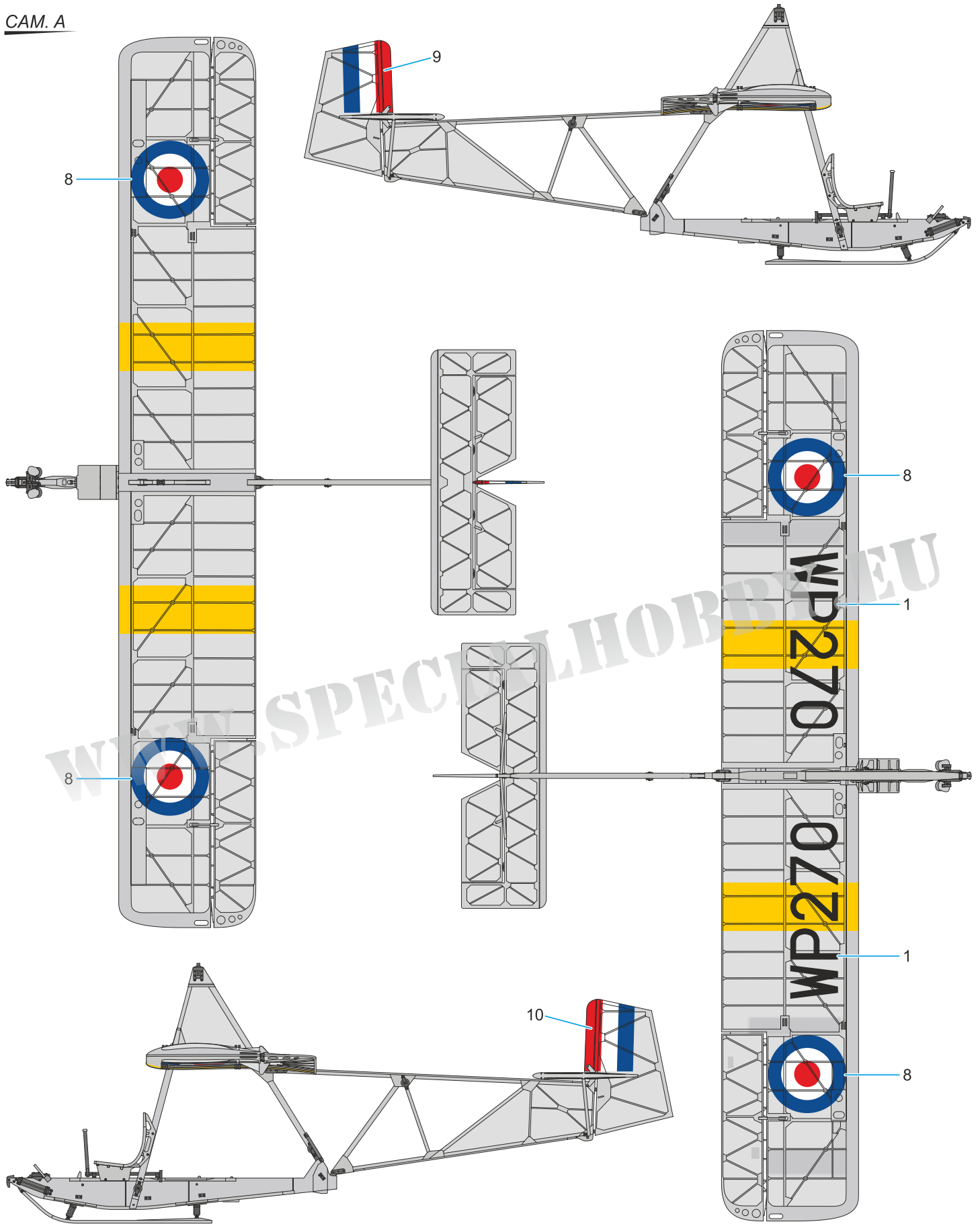

- Aluminium paint
Hliníkový nátěr
H8+11/C8+62
- Yellow
Žlutá
H329/C329



Eon Eton TX.1, WP265, c/n 033, operated by Air Cadets at RAF West Malling in the 1950s.

Eon Eton TX.1, WP265, výrobní číslo 033, používali Air Cadets na základně RAF West Malling v padesátých letech minulého století.

CAM. B

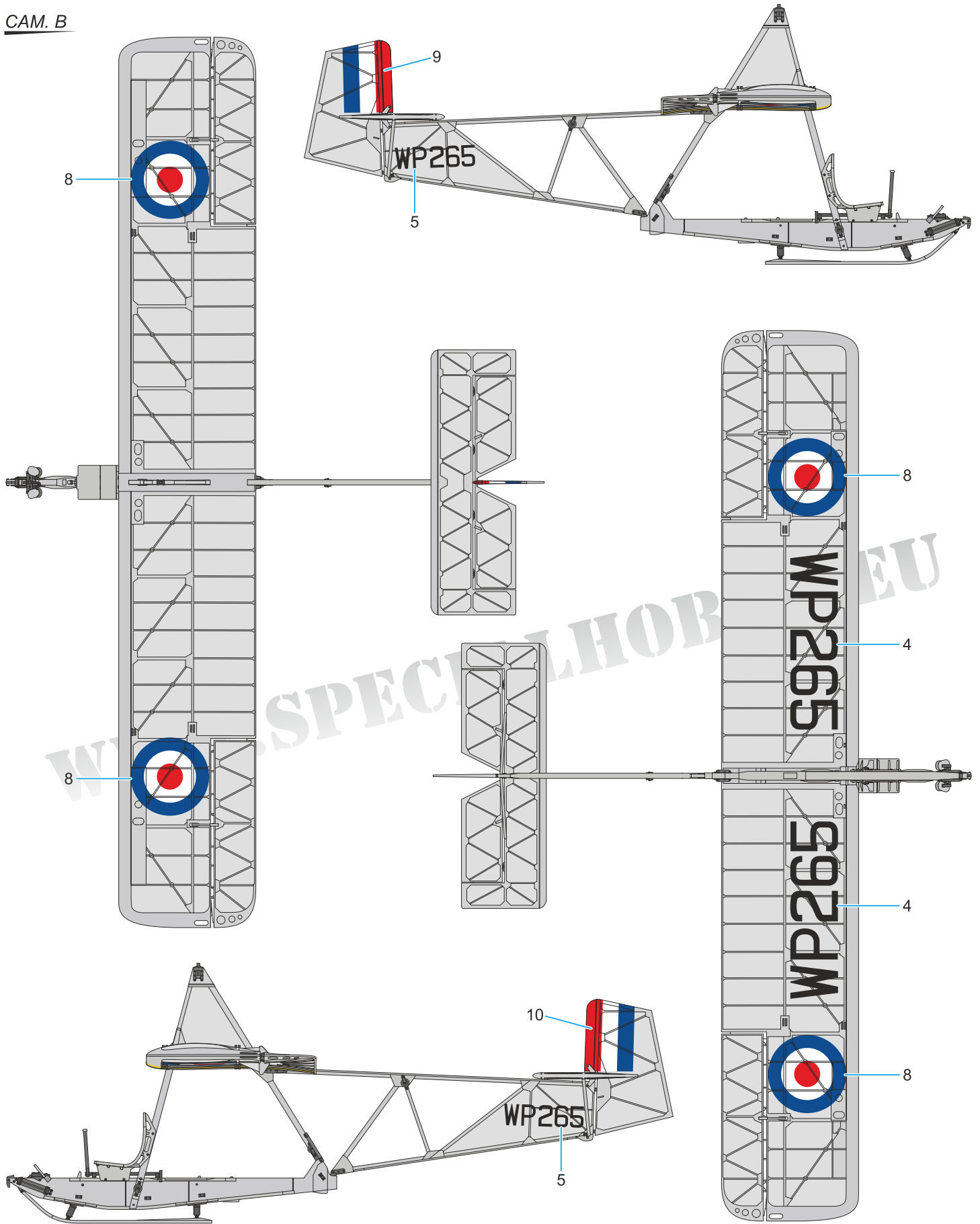





○ Aluminium paint
Hliníkový nátěr
H8+11/C8+62

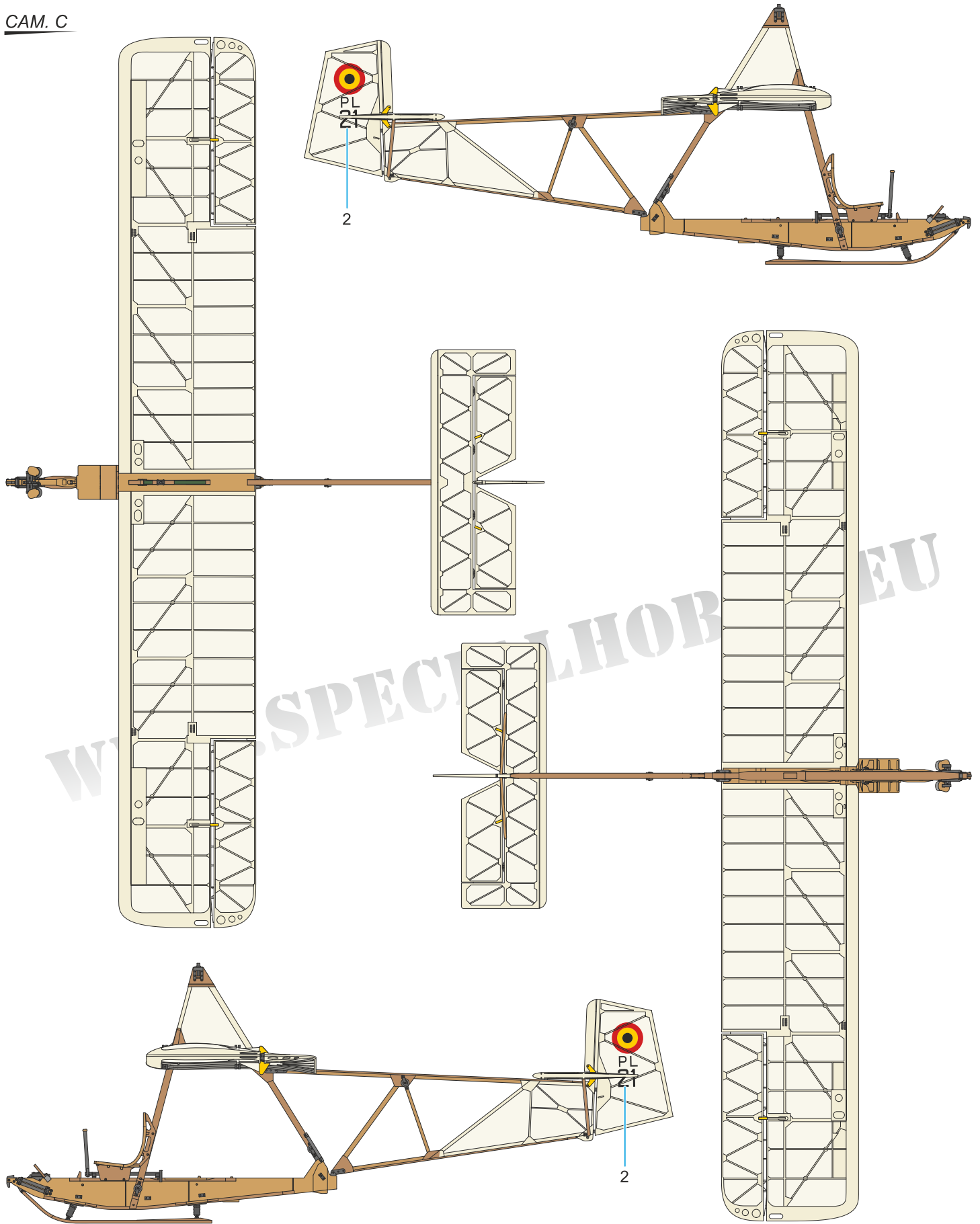

CAM. C



-  Varnished Wood
Lakované dřevo
H66/C119
-  Bleached fabric
Bělené plátno
H21/C69
-  Fabric over the wood construction
Plátno přes dřevěnou konstrukci
H21+(5%H85)/C69(5%C45)
-  Yellow
Žlutá
H329/C329



CAM. D

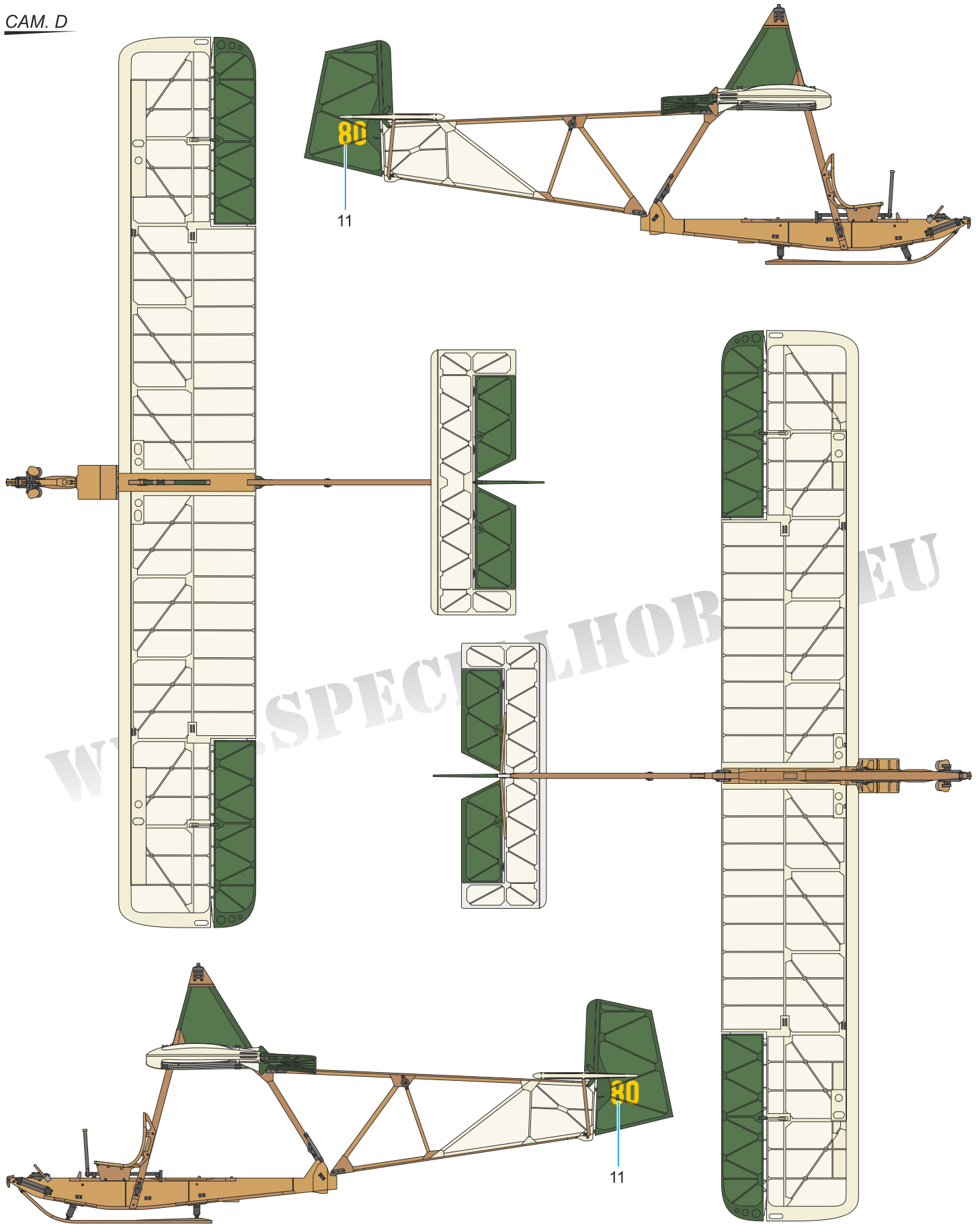

- Varnished Wood
Lakované dřevo
H66/C119
- Bleached fabric
Bělené plátno
H21/C69
- Fabric over the wood construction
Plátno přes dřevěnou konstrukci
H21+(5%H85)/C69(5%C45)
- Dark Green
Tmavě zelená
H73/C70



SG-38, No.95 "Le Timide", France 1945. An original, German-built glider, after the liberation of France used by French sport pilots.

SG-38, No.95 „Le Timide“, Francie 1945. Původně německý kluzák byl po osvobození Francie používán francouzskými sportovními piloty.

CAM. E

