

Delta Mk. III RCAF

NÁVOD / INSTRUCTIONS

CZ – Historie

Jack K. Northrop po odchodu z firmy Northrop Aircraft Corp. (Stearman-Northrop) ovládané Boeingem založil novou firmu Northrop Corp., tentokrát jako součást koncernu Douglas. Firma sídlila v Inglewoodu. Zde J. Northrop pokračoval ve vývoji moderních celokovových letadel. Při vývoji nového dopravního letounu Delta v roce 1932 navázal na své starší poštovní typy Alfa a Gamma. Delta byl celokovový jednomotorový dolnoplošník s pevným kapotovaným podvozkem. Určen byl pro spádové linky hlavních leteckých spojů. Stavěn byl v několika verzích, lišících se použitým motorem a také tvarem pilotní kabiny. První verze Delta 1A, 1B a 1C byly stavěny s úzkým překrytím pilotního prostoru, pod kterým seděl jeden pilot. Další verze 1D a 1E dostaly širší překrytí pilotní kabiny pro dva piloty a mohutnější hřbet trupu. Bohužel jeden z prvních strojů Delta 1A v Mexiku havaroval při předávacím letu. I to vedlo americkou vládu k zákazu používání jednomotorových strojů pro pravidelnou dopravu cestujících. Zákaz způsobil omezení výroby tohoto moderního stroje. Vyrobené kusy zakoupili soukromníci nebo firmy ke služebním účelům, Delta 1D c/n 74 létala u US Coast Guard. Později byl předán US Corps of Engineers a létal během druhé světové války v africké Etiopii. Stroj Delta 1D c/n 42 létal v Ellsworthově Antarktické letce při expedicích do Antarktidy. Později byl zakoupen australskou vládou a po vypuknutí druhé světové války předán RAAF. Jiné Deltly se dostaly do boje dříve. Tři byly zakoupeny španělskou vládou. Dvě ale padly do rukou nacionalistů a tak Deltly létaly na obou stranách španělské občanské války. Northropův obchodní neúspěch s letouny Delta částečně kompenzoval nákup licence kanadskou vládou v roce 1936. Kanadské Deltly byly vyráběny firmou Vickers ve verzích Mk.I až III. Zatím co verze Mk.I a Mk.II se od amerických strojů lišily jen detaily, verze Mk.III dostala ocasní plochy nového tvaru. Kanadské Deltly se používaly jako fotografické, mapovací a po vypuknutí druhé světové války i jako průzkumné, protiponorkové a cvičné. Létaly i s plováky a lyžemi.

Rozpětí: 14,63 m, délka: 10,18 m, max. rychlost 362 km/h, dostup: 6 000 m, dolet 2 655 km.

EN – History

Having left Northrop Aircraft Corp. (Stearman-Northrop) controlled by Boeing, Jack K. Northrop established along with his partner Donald Douglas a new company, called Northrop Corp. The company's premises were based at Inglewood, California. In 1932 Northrop followed his earlier and successful cargo and mail types the Alfa and Gamma and designed a new one, named the Delta. It was a all-metal, single engined low-wing monoplane with fixed undercarriage covered in spats. The type was intended to be used on short domestic routes and was built in several versions, differing by their powerplant and also the shape of the pilot's cockpit canopy. First versions known as the Delta 1A, 1B and 1C featured narrow canopy housing only one pilot. Following versions, the 1D and 1E already had a wider cockpit enabling a crew of two to sit there and they also had a much massive dorsal section of the fuselage. Unfortunately, one of the first Delta 1A machines crashed in Mexico while being delivered to the customer. This accident was also one of the reasons for the US government to ban the usage of single engined types for regular passenger transport. Aircraft already produced were bought by private subjects or used by companies for business trip purposes. One of the Delta 1Ds, with construction number 74, was used by the US Coast Guard and later it was handed over to the US Corps of Engineers and flown in African Ethiopia during the Second World War. Delta 1D c/n42 first saw service with Ellsworth's Antarctica Flight, then was bought by the Australian government and following the outbreak of WW2 it was transferred to the RAAF. Some other Deltas were lucky to see war service even earlier as three of them were acquired by the Spanish government, though two of them fell into the hands of Spanish Nationalist Forces making the Delta the type to fight or be used on both sides of the conflict. In 1936, Canada bought licence rights, partially compensating for Northrop's business failure with the type. The Canadian machines were produced by Vickers company in versions Mk.I to Mk.III. While the Mk.I and Mk.II versions differed from their American predecessors only in details, the Mk.III featured a completely redesigned tail unit. Canadian Deltas saw service in multitude of roles, they were used as photographic machines and for aerial survey, following the outbreak of WW2 they began also flying reconnaissance missions, anti-submarine patrols and were also used for training purposes. Many of them were also fitted with a pair of floats or skis.

Wingspan: 14.63 m, Length: 10.18 m, Max Speed 362 km/h, Ceiling: 6,000 m, Range: 2,655 km.

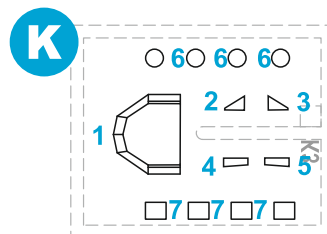
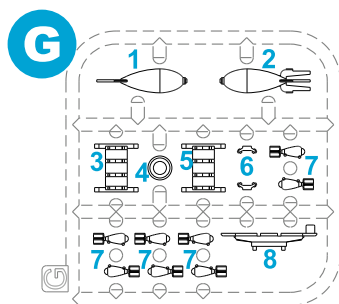
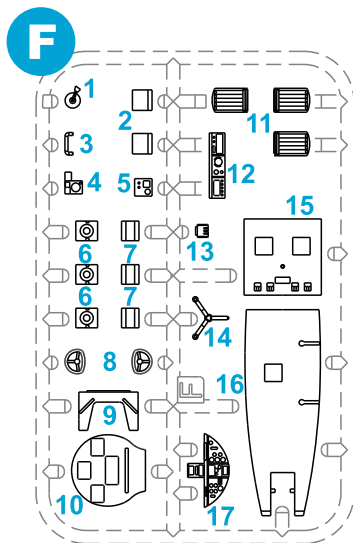
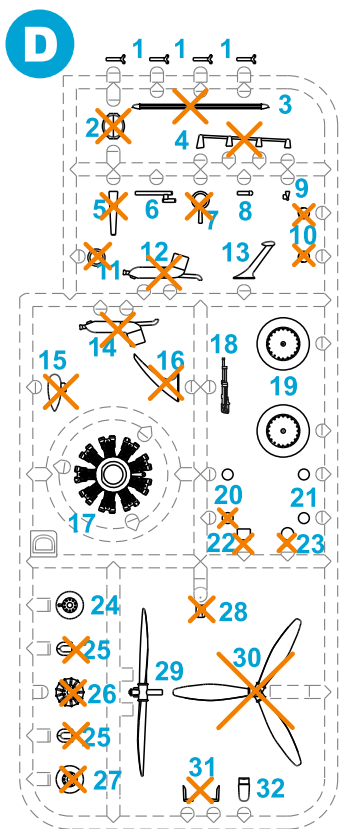
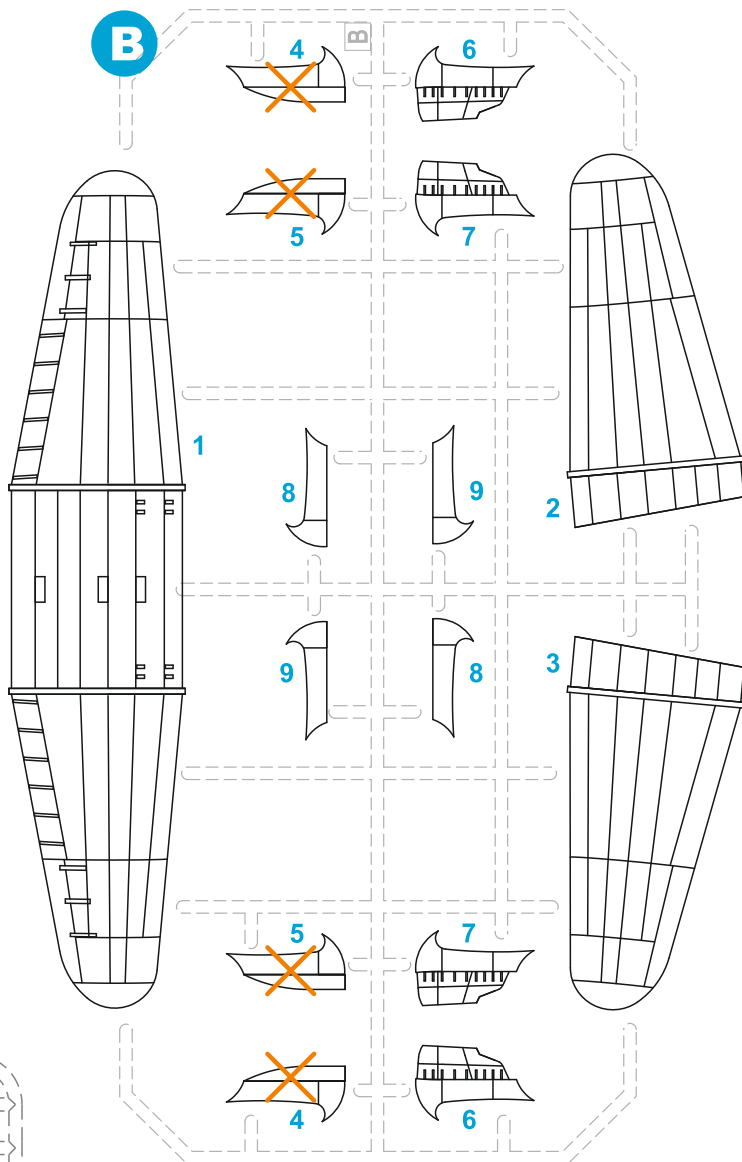
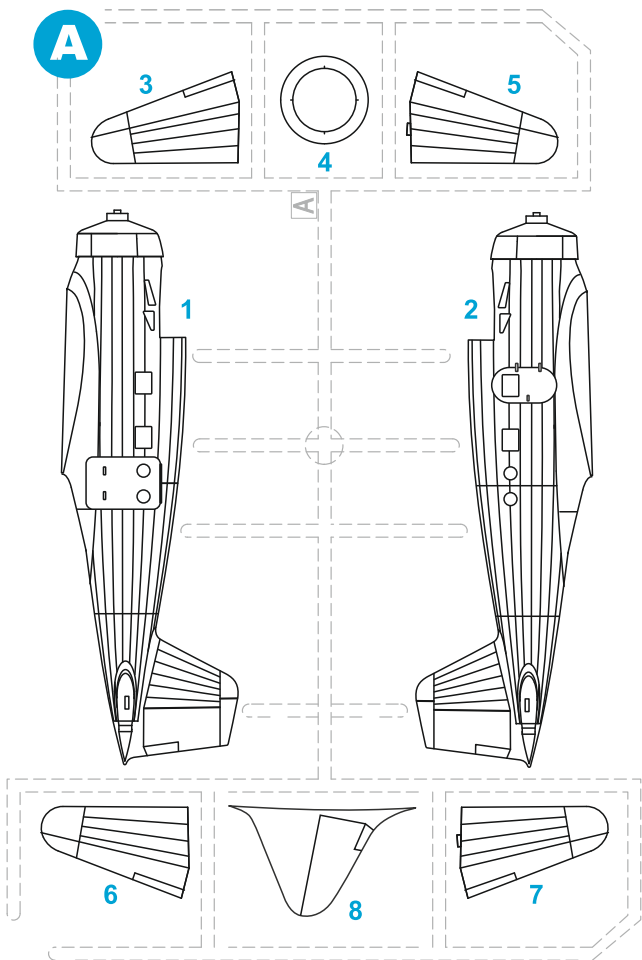

 Tento díl nepoužít.
Do not use this part.

Barvy GUNZE / GUNZE Colour No.		
A	Matná černá / Flat Black	H12/C33
B	Černá / Black	H2/C2
C	Hliník / Aluminium	H8/C8
D	Hnědočervená / Leather	H47/C41
E	Šedá / Gray	H325/C325
F	Tmavě zelená / Dark Green	H73/C23
G	Opálený kov / Burnt Iron	H76/C61
H	Barva pneu / Tire Black	H77/C137
I	Červená čirá / Clear Red	H90/C47
J	Zelená čirá / Clear Green	H94/C138

SYMBOLS

 MOŽNOST VOLBY
OPTIONAL
NACH BELIEBEN
OPTION

 POUŽÍT KYANOAKRYLÁTOVÉ LEPIDLO
INSTANT CYANOACRYLATE GLUE
ZYANOAKRYLÁTKLEBER
COLLE CYANOACRYLATE

 OHNOUT
BEND
BIEGEN
COURBER

 ZHOTOVIT NOVĚ
SCRATCH BUILD
FERTIGSTELLEN
ACHEVER

 ŘEZAT/VRTAT
CUT OFF/DRILL
ENTFERNEN
COUPER/PERCER

 NATŘÍT
COLOUR
FARBEN
PEINDRE
GSI
colour
code

1

? camo A/C only

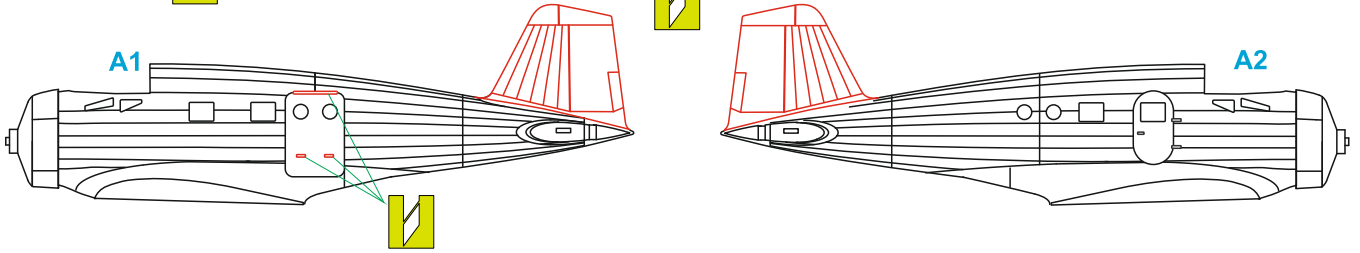

2

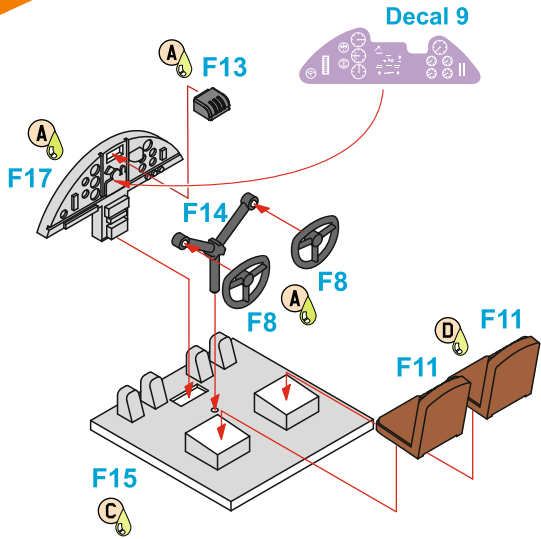

3

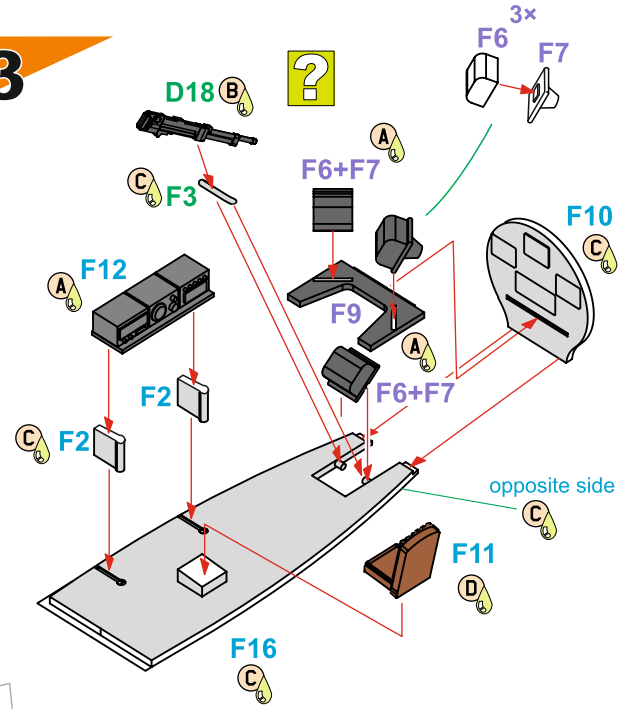

4

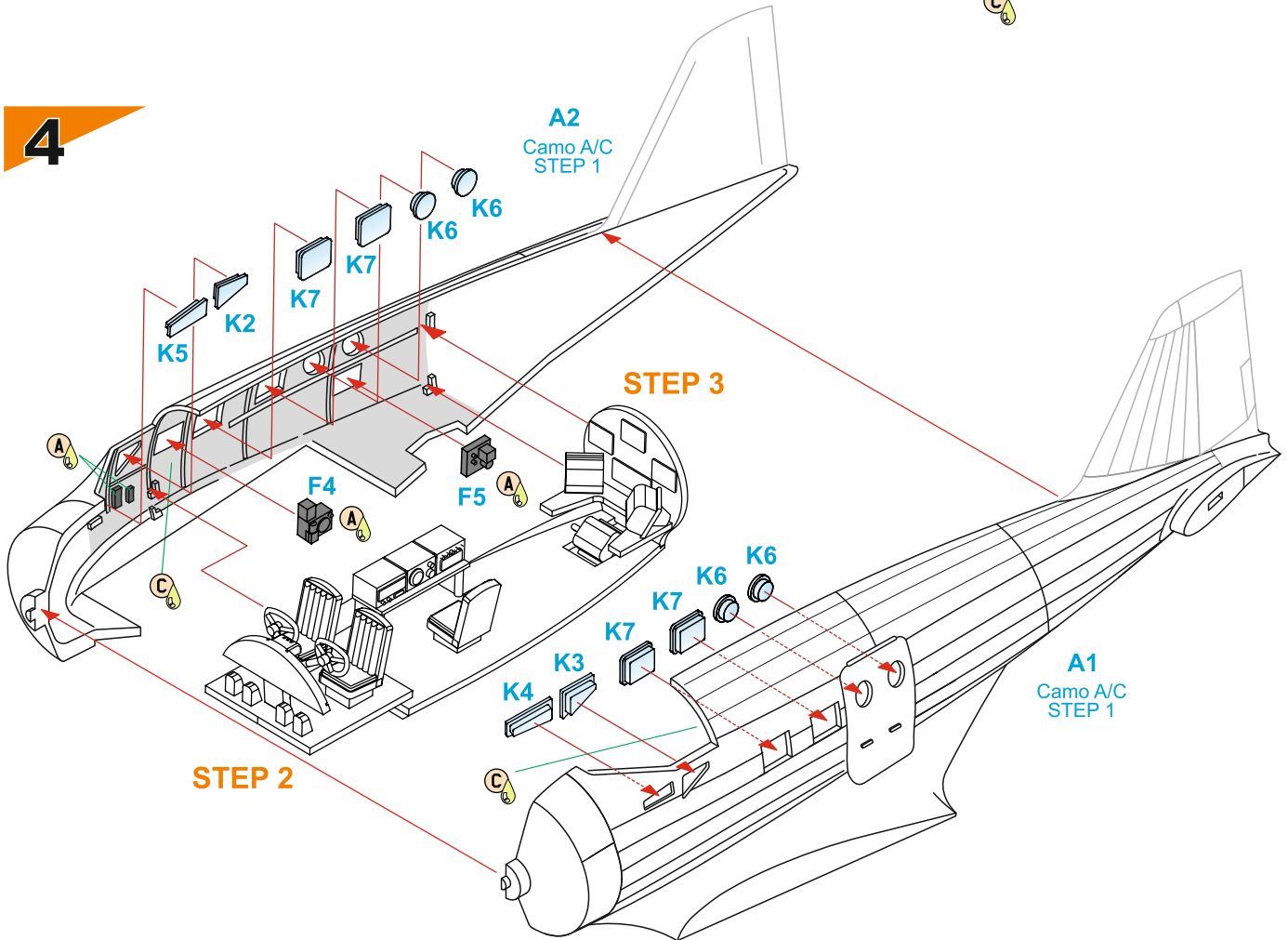

5

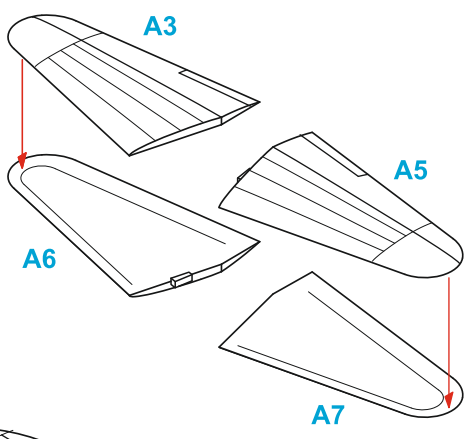

? camo A/C only

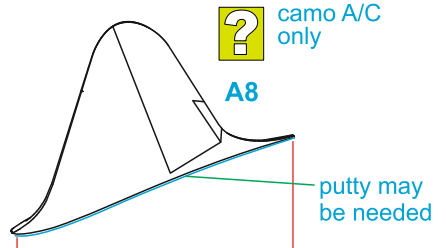

6

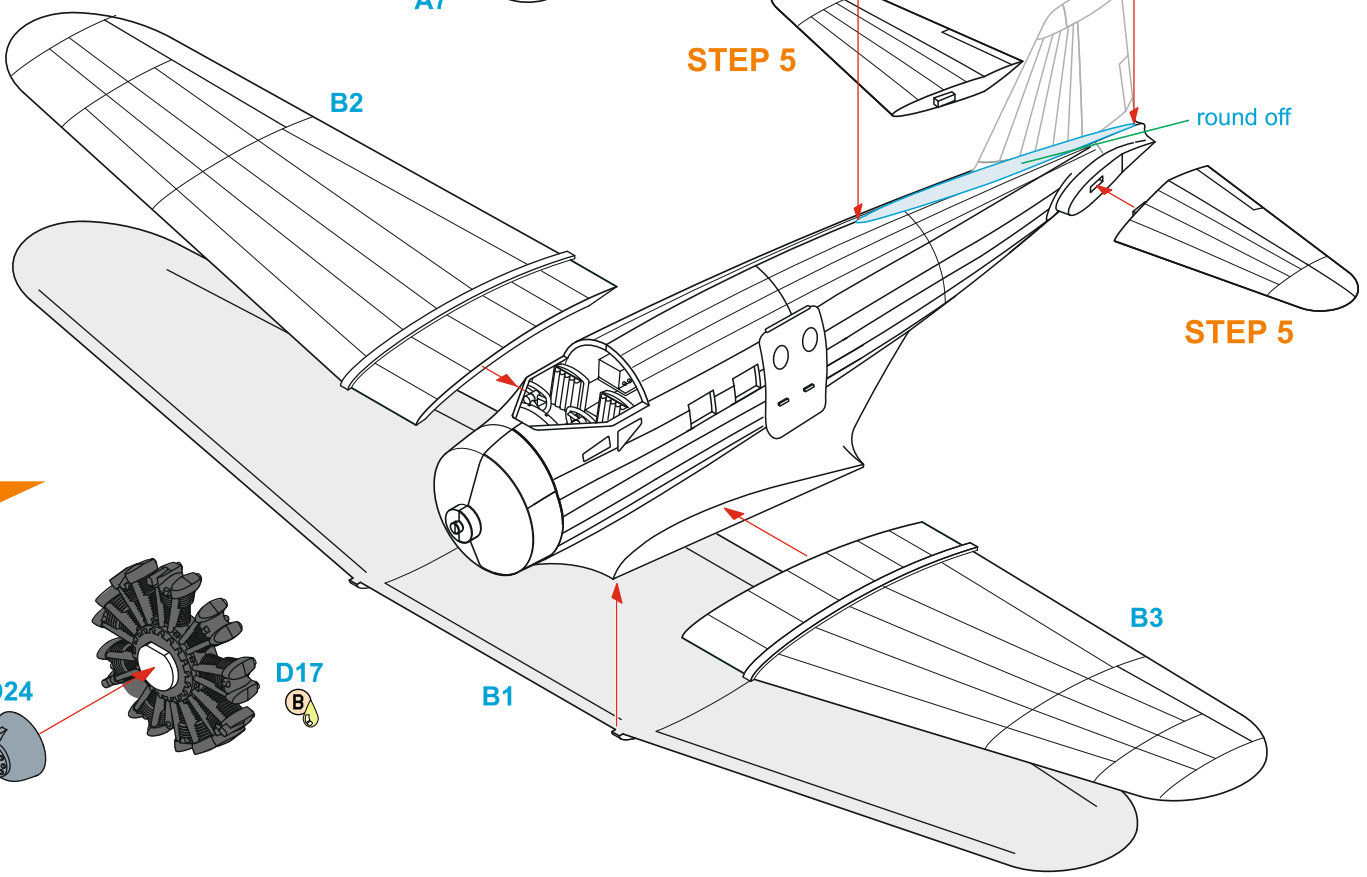

7

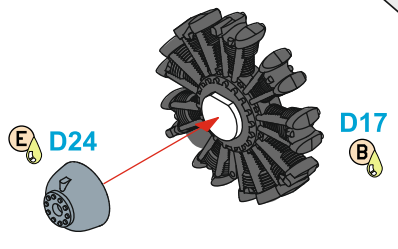

8

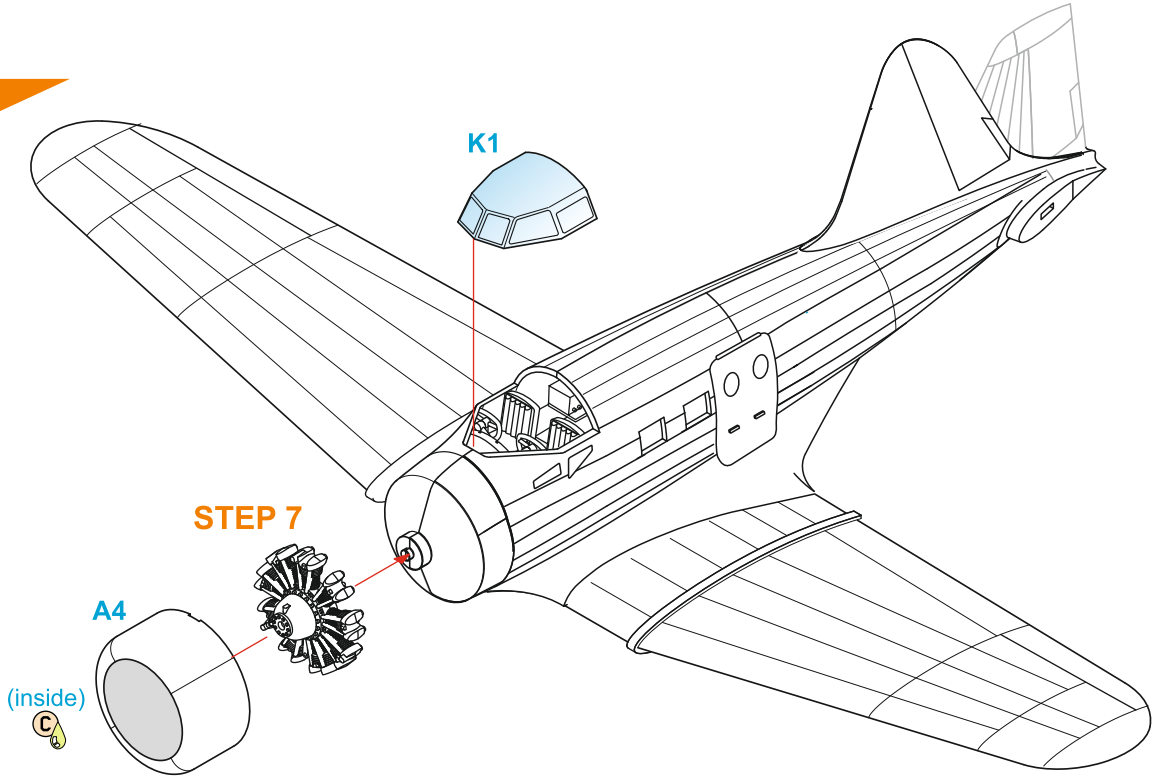

9



camo A
2x

D19

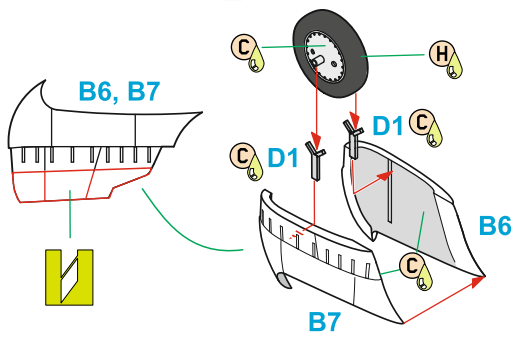

camo B
2x

D19

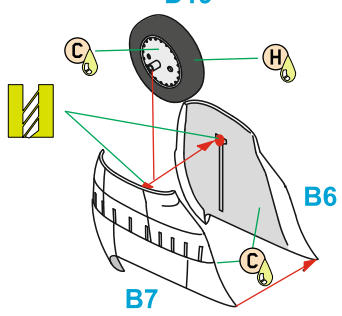

camo C
2x

D19

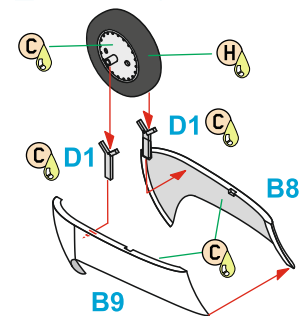

10

STEP 9
symmetrical assembly



camo C



camo B



camo A

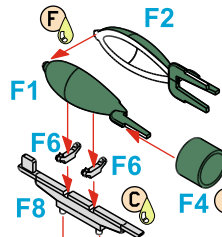

4x
F7

4x
opposite
F7 + F3

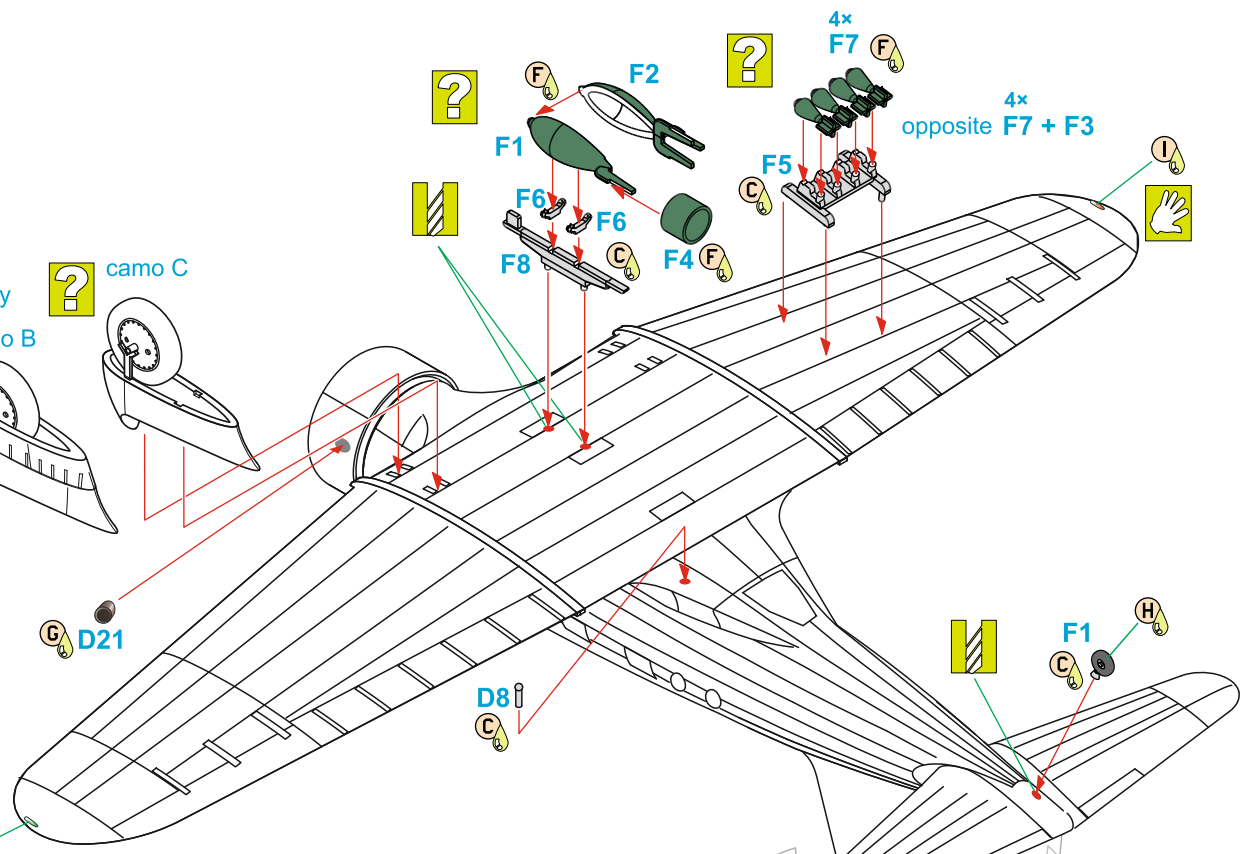

11



D29

D32

D13

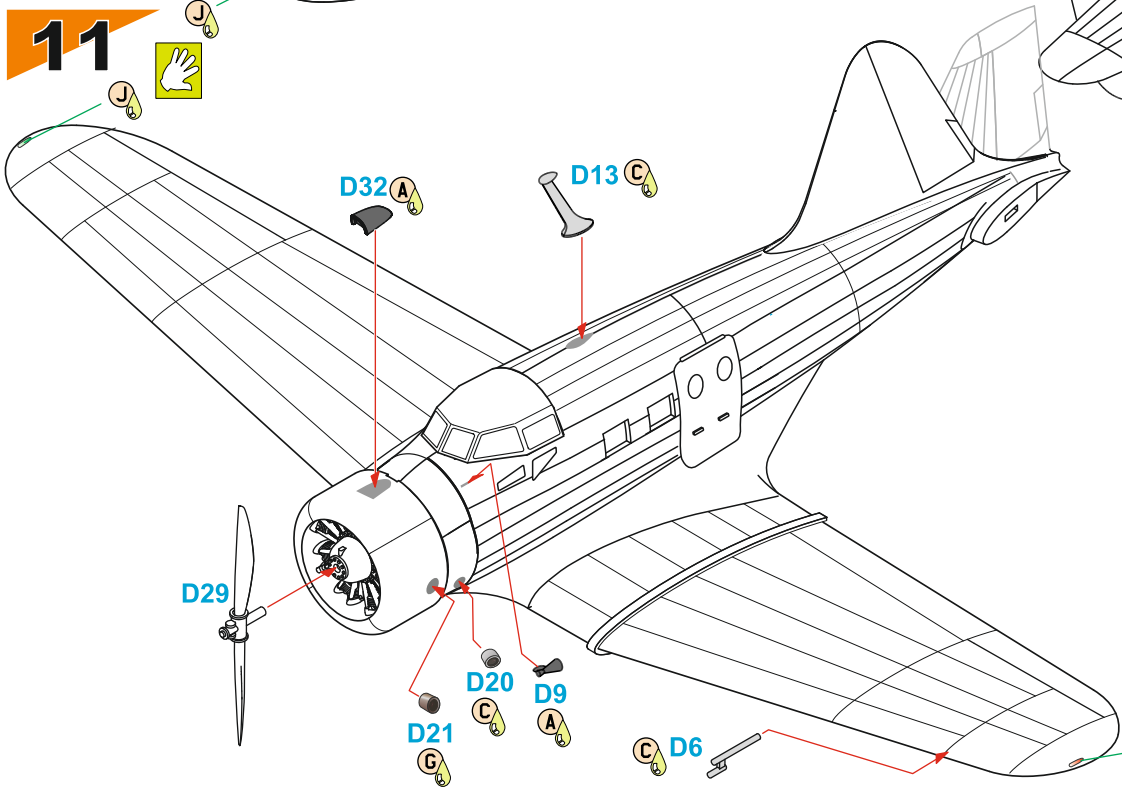

Canadian Vickers Delta Mk.III, No.685, třetí Delta postavená v této verzi. Původně, od května 1940 do července 1941 létala u 120 (BR) Sqn., Western Air Command ze základen RCAF Sea Island a Patricia Bay, v provincii Britská Kolumbie jako MX-E (přetřené kódy nyní částečně viditelné na trupu), později předána 13 (OT) Sqn, Patricia Bay a označená AN-P. Koncem roku 1941 pro Delty nebylo již žádné využití a byly převezeny či přelétuty (s novými seriály na trupu a SOP začínajícími písmenem A) do školy pozemního personálu v St.Thomas v Ontariu.

Canadian Vickers Delta Mk.III, No.685, the third Delta airframe built from the beginning in this version. Originally, since May 1940 to July 1941, it was on strength of 120 (BR) Sqn, Western Air Command at RCAF Stations Sea Island and Patricia Bay in British Columbia (overpainted fuselage code letters now slightly visible), later moved to 13 (OT) Sqn, Patricia Bay, coded AN-P. By late 1941, the Deltas had already been of no use for the RCAF and it was decided they would be used as instructional airframes in Technical Training School at St.Thomas, Ontario, with new fuselage and tail serials beginning with letter A.

CAM. A

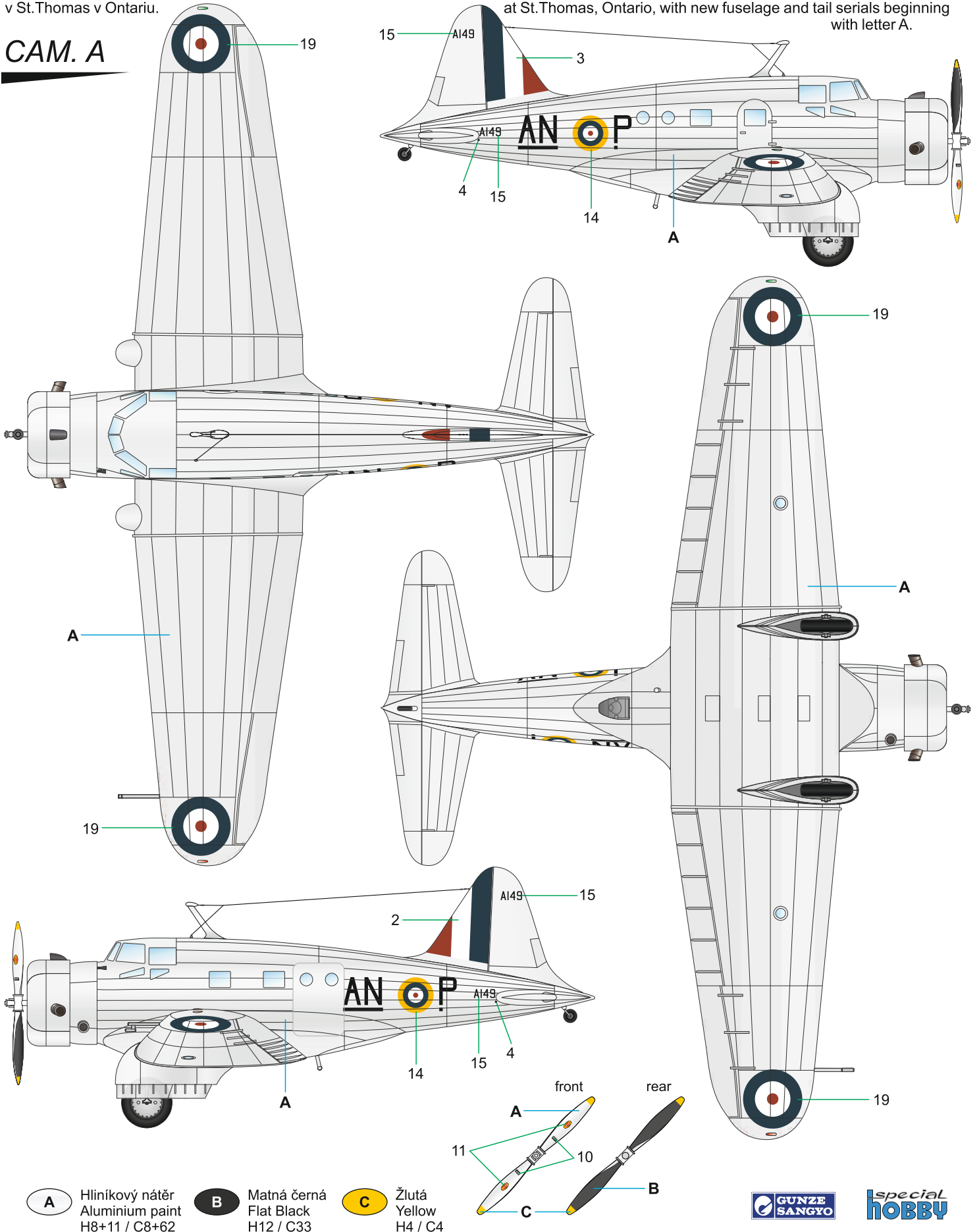

Canadian Vickers Delta Mk.I/II/III, No. 667, první Delta vyrobená v Kanadě. Přijata do stavu RCAF 1.září 1936 vybavená plováky a předána No. 6 (GP) detachment, No.8 (GP) Sqn v Rockcliffe, Ottawa. V zimě 37-38 přestavěná do standardu verze Mk.II, později v roce 1938 dostala i větší SOP a stala se verzí Mk.III. 27.dubna 1941 byla předána 120 (BR) Sqn v Patricia Bay a kariéru zakončila jako A-143 ve škole pozemního personálu.

Canadian Vickers Delta Mk.I/II/III, No.667, the first Delta to be manufactured in Canada. Accepted by the RCAF on 1 September 1936, on floats and transferred to No.6 (GP) detachment, No.8 (GP, later BR) Sqn, Rockcliffe, Ottawa. In the winter of 1937-38, the machine was rebuilt to Mk.II standard and later that year it was also fitted with redesigned empennage, becoming a Mk.III version aircraft. On 27 April 1941, it was taken on strength of 120 (BR) Sqn at Patricia Bay and finished its career in the ground crew training school serialised A-143.

CAM. B

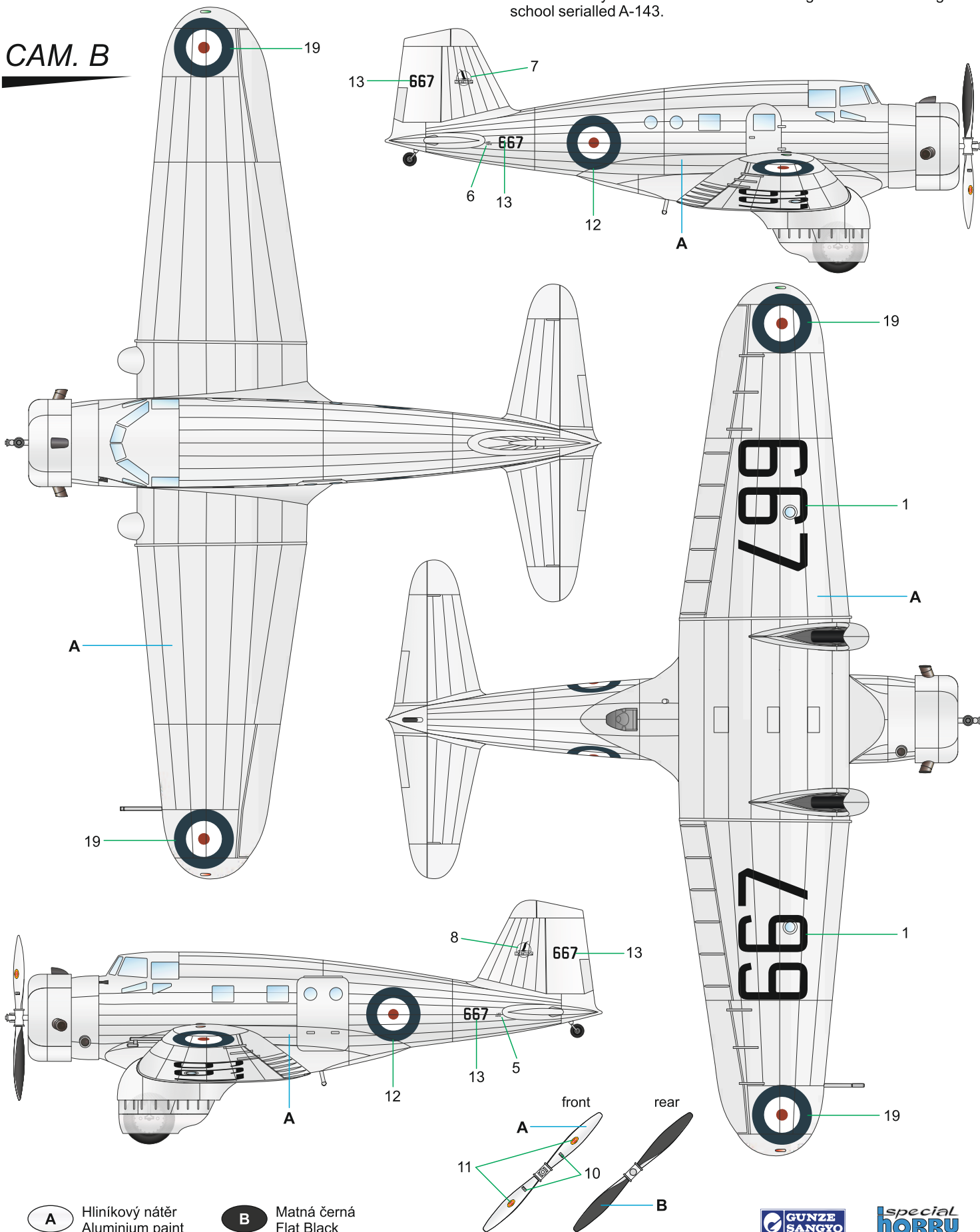

A Hliníkový nátěr
Aluminium paint
H8+11 / C8+62

B Matná černá
Flat Black
H12 / C33

GUNZE
SANGYO

special
HOBBY

Canadian Vickers Delta Mk.III, No.690, poslední vyrobená kanadská Delta. Původně, od října 1940, létala s kódem MX-J ve stavu No.120 (BR) Sqn., Western Air Command, RCAF Jericho Beach v Britské Kolumbii. Předána (se zamalovanými ale silně prosvítajícími trupovými kódy) 13 (OT) Sqn., Patricia Bay. 2.listopadu 1941, než mohl být přelétnuta do školy v Ontariu, utrpěla během přistávání nehodu, při které se vylomila levá podvozková noha a letoun se postavil na nos.

Canadian Vickers Delta Mk.III, No.690, the final Canada-built Delta. In October 1940 it joined 120 (BR) Sqn, Western Air Command at RCAF Jericho Bay, British Columbia, and later was moved (with codes overpainted but still quite visible on the fuselage) to 13 (OT) Sqn at Patricia Bay. On 2 November 1941, prior to delivery to the ground crew school, its pilot ground-looped it on landing, damaging the port undercarriage leg and nosing the plane over.

CAM. C

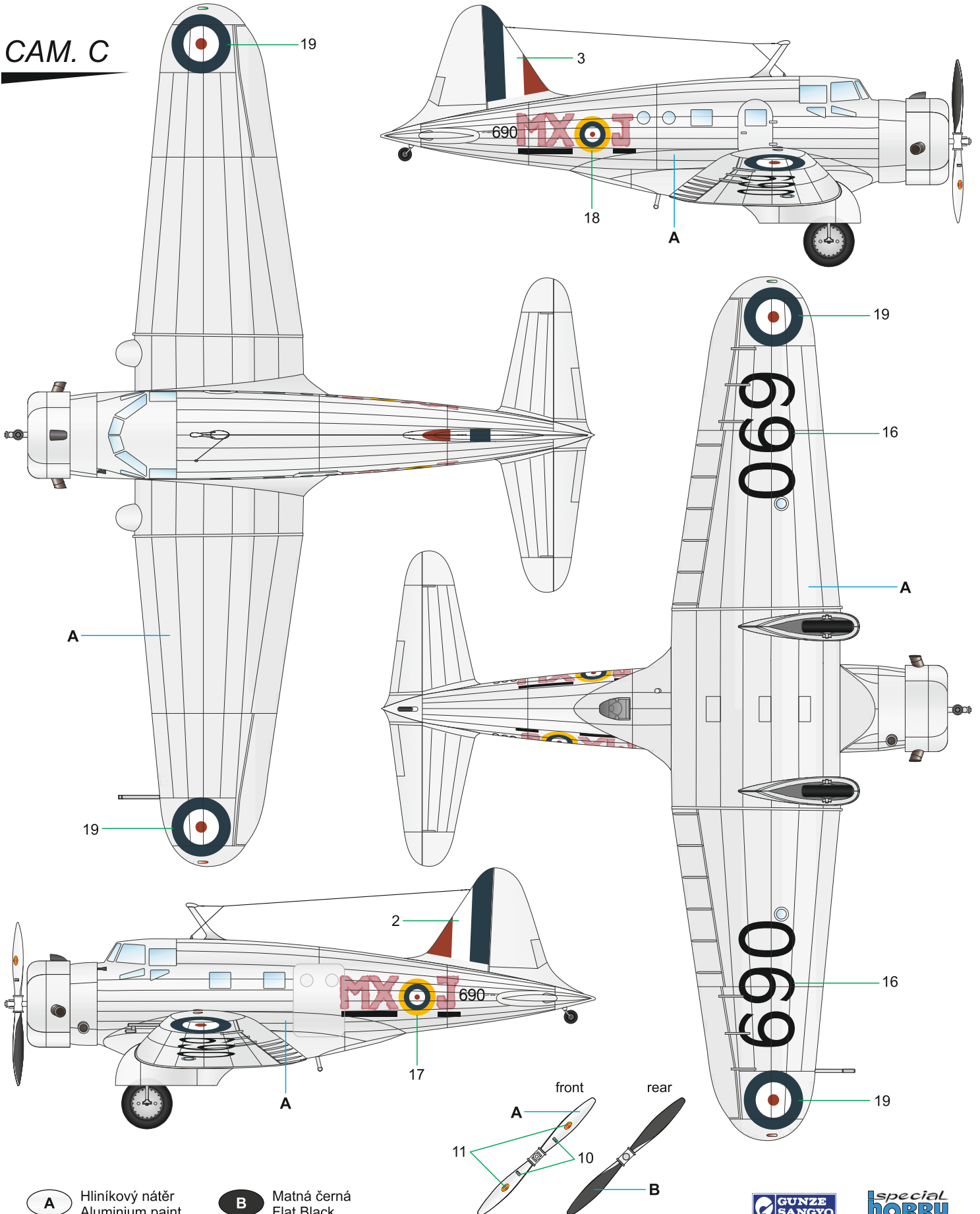

A Hliníkový nátěr
Aluminium paint
H8+11 / C8+62

B Matná černá
Flat Black
H12 / C33

