

Tempest Mk.II "HI-TECH" CZ

Historie

V průběhu leteckých bojů druhé světové války obě válčící strany musely reagovat na zavedení nových, výkonnějších typů letadel protivníka. Nasazení nové německé stíhačky Fw 190 v roce 1941 přineslo nejen spěšný vývoj nových verzí stíhačky Spitfire, ale i urychlené zavedení nových stíhaček Hawker Typhoon Mk.I do řadové služby. Zavedení Typhoonu bylo tak překotné, že se dětské nemoci jeho konstrukce a z počátku velmi poruchového šoupátkového čtyřadvacetiválcového motoru Napier Sabre odstraňovaly až během bojové služby. Brzy se ukázalo, že Typhoon má sice úžasné výkony v malých výškách, ale silný profil křídla a prudce klesající výkon jeho motoru ve výškách nad 5000 m neumožňuje jeho nasazení jako klasické denní stíhačky. (Díky vynikajícím vlastnostem v malých výškách byl nejprve používán jako záchranný stíhač pro malé výšky a pak do konce války jako vynikající stíhací-bitevní letoun).

Hlavní konstruktér Sydney Camm si byl konstrukčních omezení Typhoonu vědom a po konzultacích s Director of Technical Development at Air Ministry zahájil vývoj nového letounu. Ten vycházel z Typhoonu a nesl předběžné označení Typhoon Mk.II. V průběhu konstrukčních prací bylo reagováno na připomínky bojových pilotů létajících na Typhoonech. Změn konstrukce bylo nakonec tolik, že nový letoun dostal jméno Tempest. Byl poslední konstrukcí S. Camma s trubkovou konstrukcí střední části trupu (další jeho stíhací typy měly již konstrukci skořepinovou). S. Camm navrhl několik verzí, lišících se pohonnou jednotkou. Tempest Mk.I s motorem Napier Sabre IV a chladič zůstal v prototypu díky problémům s pohonnou jednotkou. Tempest Mk.II s motorem Bristol Centaurus IV nabízel vyšší výkony a odolnost hvězdicového motoru proti poškození. Byl vybrán do sériové výroby jako hlavní verze. Problémy s spolehlivostí motoru ale způsobily, že první sériové stroje se dostaly k bojovým jednotkám na jaře 1945 a do bojů již nezasáhly. Tempesty Mk.III a Mk.IV měly být poháněny motory R&R Griffon. Díky nedostatku motorů (byly přednostně určeny pro nové verze Spitfirů a stroje námořního letectva) nebyly tyto verze vůbec vyrobeny. Do sériové výroby se díky tomu dostala verze Tempest Mk.V s motorem Sabre Mk.II. Jeho prototyp HM595 vznikl přestavbou prototypu Tempestu Mk.I (a ten zase modifikací trupu Typhoonu téhož sériového čísla). Měl, jako všechny Tempesty nové eliptické křídlo s laminárním profilem. Během testování prototypu byly zvětšeny ocasní plochy a zavedena kapkovitá kabina s překrytem odsunovaným vzad. Do testování se zapojily i další prototypy, navíc byly využity zkušenosti bojových pilotů, hlavně S/L R.P. Beamonta, který se na vývoji Tempestu přímo podílel. Co nejrychleji byla zavedena sériová výroba, která dala přibližně sto kusů varianty Tempest Mk.V series 1 s kanóny staršího typu B. Hispano Mk.II a pak přešla na Tempest Mk.V series 2 s kanóny B. Hispano Mk.V. Stroj HM595 posloužil i jako prototyp poslední sériové bojové verze Tempest Mk.VI. Tato verze dostala vylepšený motor Sabre Mk.V. Potřeba lepšího chlazení výkonnějšího motoru vedla k přesunu chladiče oleje a sání karburátorů do kořene křídla. Vzhledem k tomu, že se počítalo s nasazením na blízkém a středním východě, dostala tato verze pouští filtr pod trup. Výroba byla zahájena v roce 1944, ale do bojů se tato verze dostala až v období vzniku státu Izrael a první arabsko-židovské války.

Do bojů druhé světové války se Tempesty Mk.V zapojily v květnu 1944 v rámci 150. wingu (No.3, No.56 a No.486 (RNZAF) sqn.) pod vedením W/Cdr. R.P. Beamonta. Ten také jako první pilot Tempestu sestřelil 8.6.1944 nepřátelský letoun. Zatím co letouny 150. wingu byly nasazeny proti střelám V-1, Tempesty byly urychleně zaváděny k dalším jednotkám v rámci 2.TAF. Až do konce války byly Tempesty nasazovány k vybojování vzdušné převahy, útokům na pozemní cíle a díky dlouhému doletu dálkovým přepadům letišť a jiných cílů v nepřátelském zázemí. Vzhledem k výkonům se plně vyrovnaly všem nepřátelským stíhačkám a větší nebezpečí jim hrozilo od nepřátelské letadlové palby. Staly se symbolem vítězství RAF na konci války. Po válce tvořily Tempesty Mk.V a také Mk.II výzbroj britských okupačních sil v Německu a sloužily i na domácích ostrovech. Část Tempestů Mk.V byla přestavěna na vlekače terčů a přeznačena na TT.5. Tempesty Mk.II byly nasazeny i v Indii a Malajsku v rámci operace Firedog proti komunistickým povstalcům. Tempesty Mk.VI sloužily v poválečném období v Palestině a Iráku. Tempesty Mk.II byly dodány po válce Indickému a Pákistánskému letectvu.

Rozpětí: 12,50 m, délka: 10,26 m, max. rychlost: 685 km/h ve výšce 5 600 m, dolet/s př. nádržemi: 1190 km/2460 km, dostup: 11 150 m, výzbroj: 4x kanón ráže 20 mm

History

During WW2 the opposing sides were constantly competing against each other to keep abreast of the latest technological developments and as a result this led to ever more powerful and effective warplanes. In 1941 the new Fw 190 fighter began to enter service and the British hastily developed the Spitfire Mk.V into the Mk.IX with a better engine, and also introduced a new type called the Hawker Typhoon Mk.I into the service too. The Typhoon airframe and engine (a H-24-cylinder sleeve valve Napier Sabre powerplant, extremely unreliable at first) were both rushed into service and they suffered from a number of teething troubles which were gradually improved during the service life of the aircraft. The new Typhoon proved to be superior in performance against the Fw 190 at low altitude, but due to the thick wing airfoil section and the fact that the performance of the engine decreased at heights above 5,000m, it became clear that the Typhoon would not fit the requirements for a standard day fighter aircraft. Therefore the Typhoon was used primarily as a low altitude interceptor fighter aircraft but it was soon developed into an outstanding fighter-bomber, a role for which it became famous.

Sir Sydney Camm, Hawker's chief designer famous for the Hurricane, was fully aware of restrictions of his Typhoon design. Following lengthy discussions with the Director of Technical Development at the Air Ministry he began to design a new aircraft partially based on the Typhoon. At first this was known as the Typhoon Mk.II but as it developed, taking into consideration the observations of operational Typhoon pilots, so many alterations were made to the basic design (e.g. all new elliptical shaped laminar flow cross-sectioned wing) that it was renamed as the Tempest. This was Camm's last design to incorporate the tubular framed structure of the mid fuselage section as all of his subsequent aircraft would be fully monocoque structures instead.

The new Tempest was originally planned to be built with three totally different powerplant options. The Mk.I was fitted with a Napier Sabre IV engine and had the radiators mounted in the wings but it did not progress beyond the prototype stages in this form. The Tempest Mk.II with Bristol Centaurus IV powerplant seemed to offer much higher performance and it was better suited to tropical conditions so it was approved for full production but unfortunately problems with the Centaurus and a low development priority for this version prevented the machine from reaching operational units until the spring of 1945 and so it saw no action in WW2. The Tempest Mk.III and Mk.IV were supposed to be fitted with R&R Griffon powerplants, but these engines were in short supply as the Spitfire and Firefly took precedence for this powerplant and therefore these versions just never materialised.

Due to delays with the Tempest Mk.II programme caused by problems with the Centaurus, the Napier Sabre option was developed further and it finally led to the Tempest Mk.V powered by the improved Sabre II and this was the only Tempest variant to see front line use during WW2. The prototype for the Mk.V variant was HM595 (originally flown as the Tempest Mk.I prototype too) but in its new form the radiator was moved to the chin position and some alterations to the airframe were incorporated during testing including an enlarged tail plane and rearward-sliding bubble-shaped cockpit canopy. Several other pre production Mk.V's were used during the development phases and one of the operational pilots involved in these trials was Sqn. Ldr. R.P. Beamont.

The Tempest Mk.V was rushed into production and the first one hundred or so machines consisted of the Tempest Mk.V series 1 variant with earlier British Hispano Mk.II cannon. Later variants, known as the Tempest Mk.V series 2 were fitted with shorter barreled Mk.V cannons. Tempest HM595 was also used as the prototype for the final Tempest version, the Mk.VI which had an improved Sabre Mk.V powerplant. The additional power of this engine needed a much more efficient cooling system and this led to relocation of an additional radiator and the carburettor air intake into the wing root section. As this final variant was also supposed to fly over desert areas of the Middle East it was tropicalised using a dust filter under the centre section of the wing. This version did not enter service until after WW2 but saw limited and unfortunate action with the RAF during the first Arab-Israeli war in 1948.

The Tempest Mk.V entered operational service in May 1944, serving with No.150 Wing (Sqn No.3, No.56 and No.486 (RNZAF)) under the command of W/Cdr R.P. Beamont. He was also the very first Tempest pilot to achieve an aerial victory, this occurring on June 8, 1944. The Tempest was the fastest Allied piston-engined type during WW2 and due to this 150 Wing were retained in the UK to help counter the V1 flying bomb offensive. As more Tempests entered service they went on to equip units of the 2nd TAF in NW. Europe. Until the end of hostilities in Europe, the Tempests were used mainly in the aerial superiority role and thanks to their high performance, the Mk.V version was on a par with all comparable enemy fighter aircraft. But by this late stage of the war the main threat came from enemy anti-aircraft fire, especially while undertaking ground attack sorties.

Following the end of the war, the Tempest Mk.V and Mk.II went on to equip the majority of British Air Force of Occupation units serving in Germany. Some of the Mk.V's were converted to become TT.MK.5 target tugs which were used by RAF Armament Practice Camps in the UK and Germany. The Tempest Mk.II also saw post war service in pre partition India and later in Malaya where they saw action against communist insurgents during Operation Firedog. After India was partitioned the Tempest Mk.II was supplied to the new air forces of both India and Pakistan. The Mk.VI Tempest also saw post-war service in Palestina and Iraq.

Wingspan: 12.50 m, Length: 10.26 m, Top Speed: 685 km/h at 5,600 m, Range / with ext.fuel tanks: 1,190 km/2,460 km, Ceiling: 11,150 m, Armament: 4x 20 mm cannon

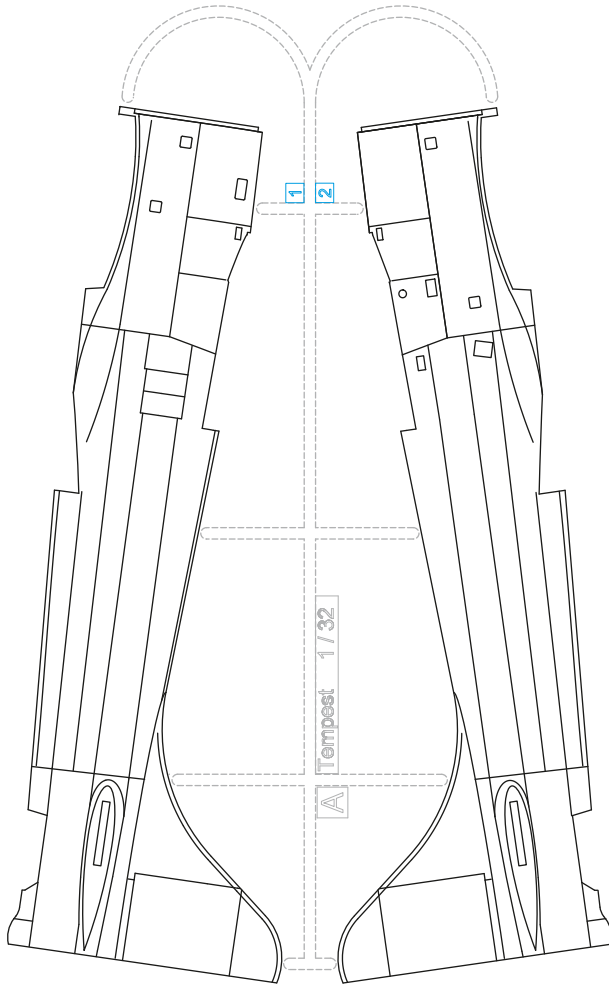
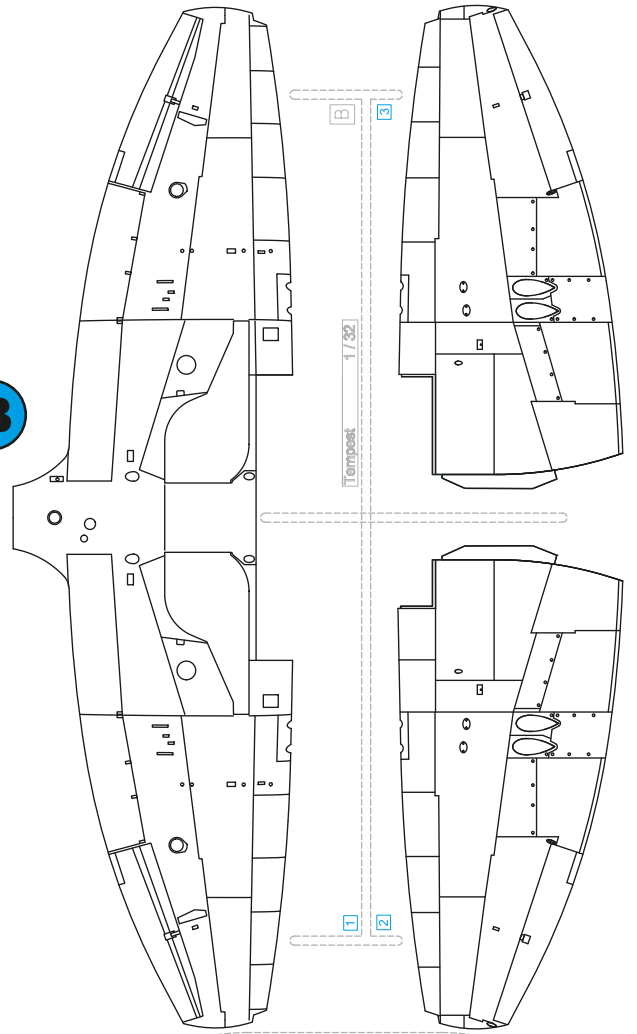
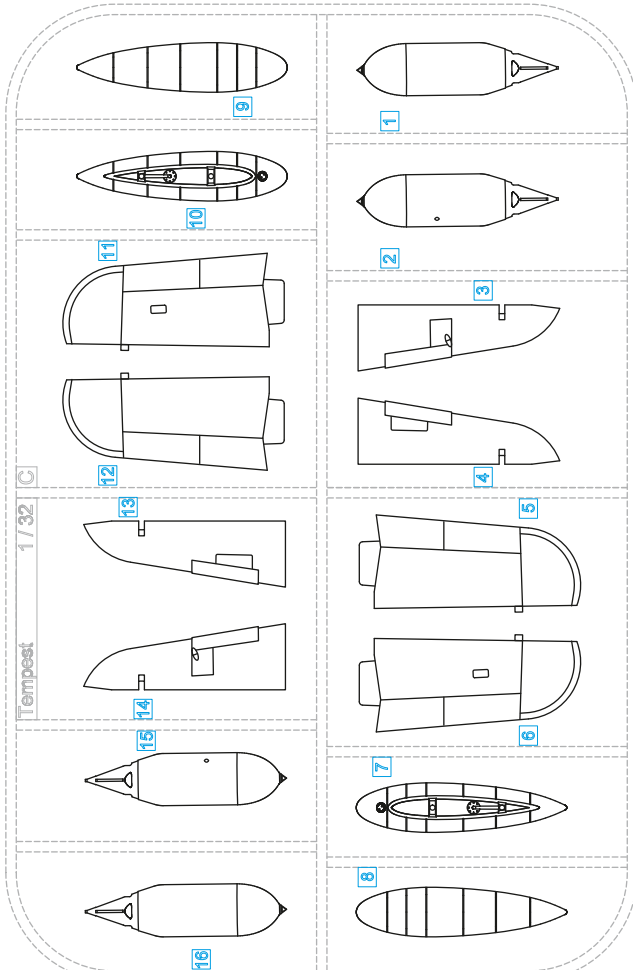
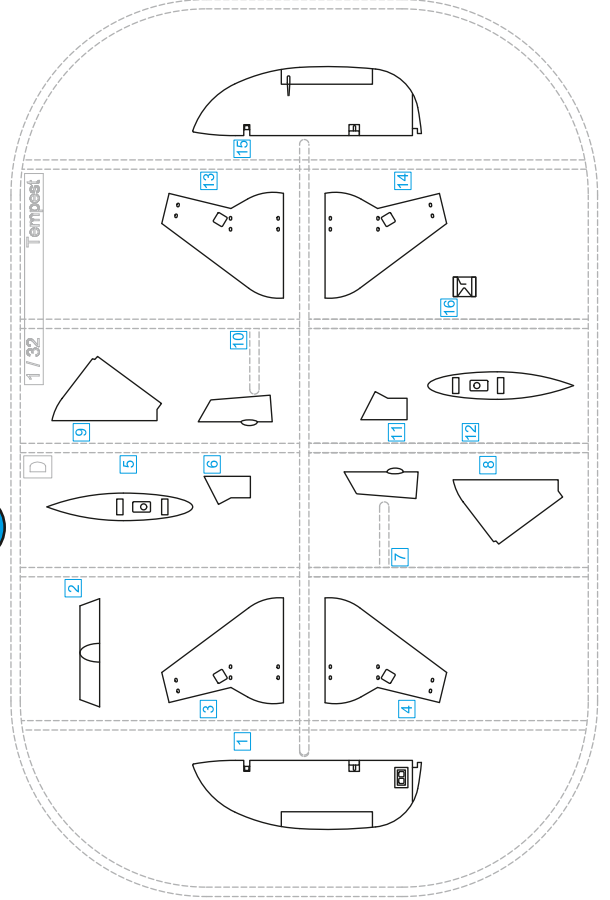
A**B****C****D****SYMBOLS**

MOŽNOST VOLBY
OPTIONAL
NACH BELIEBEN
OPTION



POUŽIT KYANOAKRYLÁTOVÉ LEPIDLO
INSTANT CYANOACRYLATE GLUE
ZYANOAKRYLÁTKLEBER
ADHÉSIF CYANOACRYLAT



OHNOUT
BEND
BIEGEN
COURBER



ZHOTOVIT NOVÉ
SCRATCH BUILD
FERTIGSTELLEN
ACHEVER



ŘEZAT/VRTAT
CUT OFF/DRILL
ENTFERNEN
DETACHER

GSI **A**
colours code

NATŘÍT
COLOUR
FARBEN
PEINDRE

F

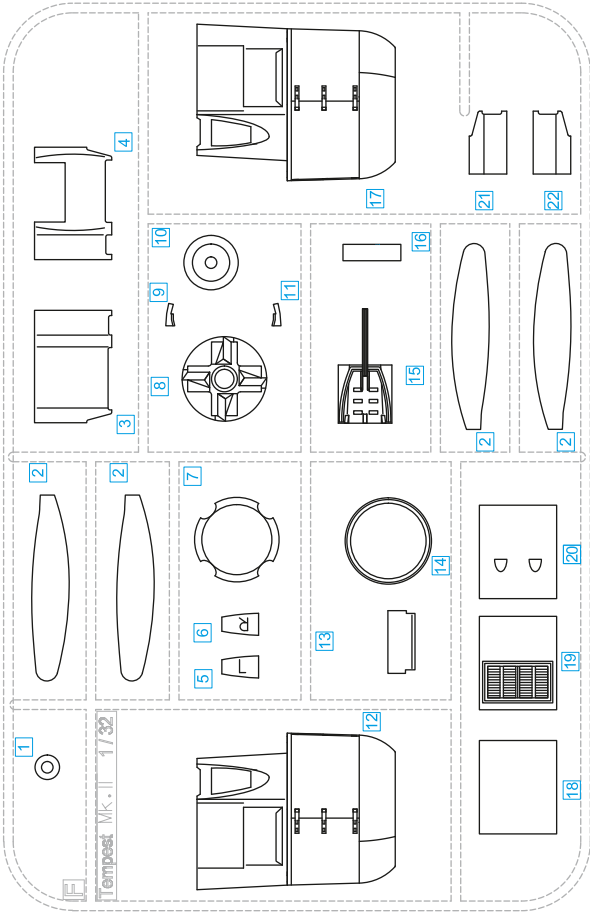

H

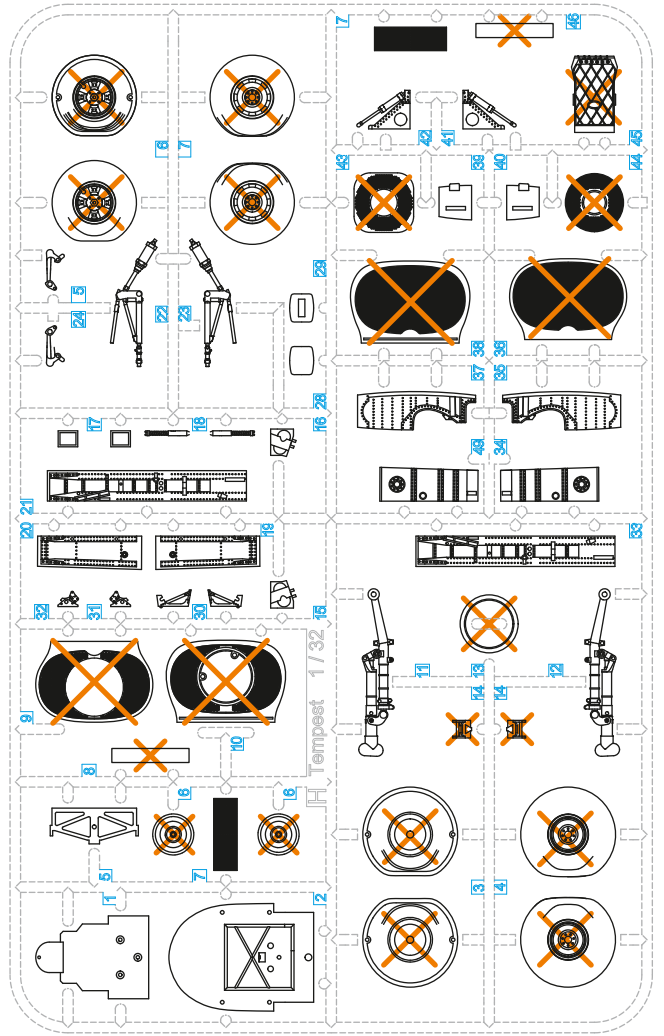

I

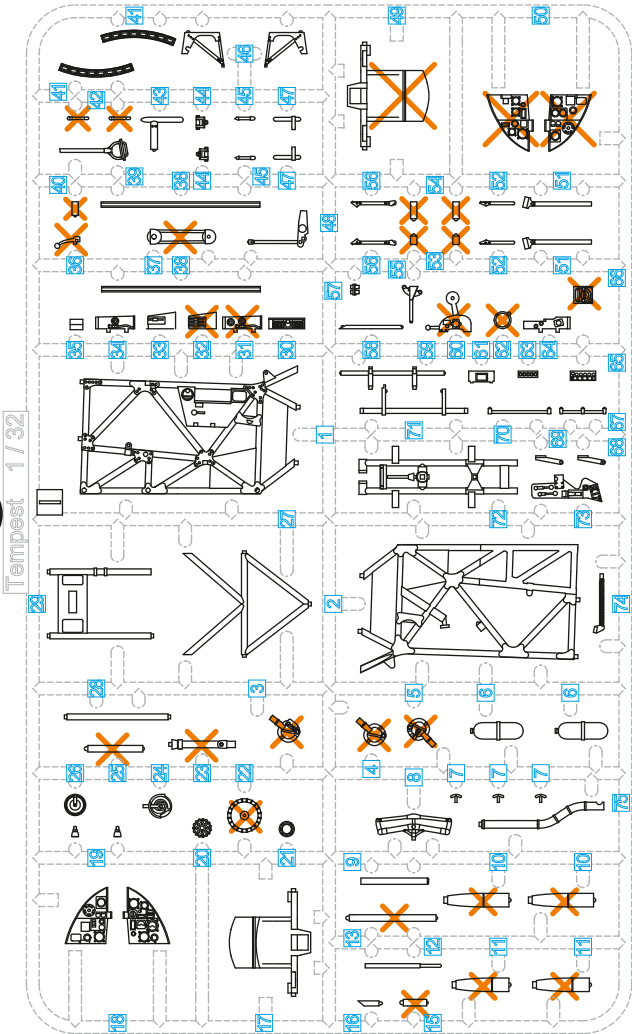

J

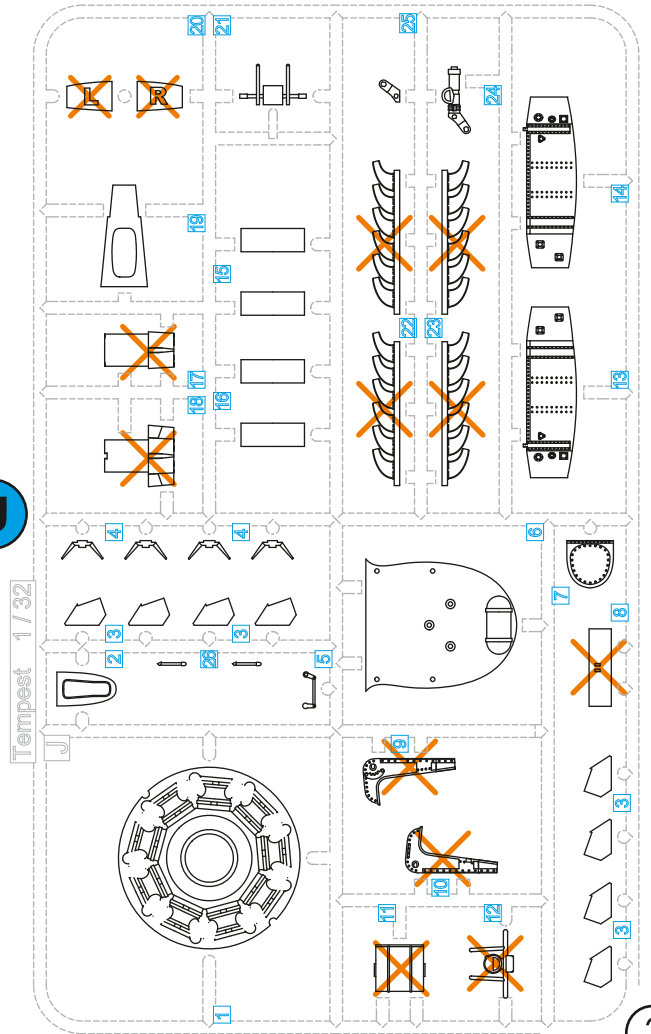

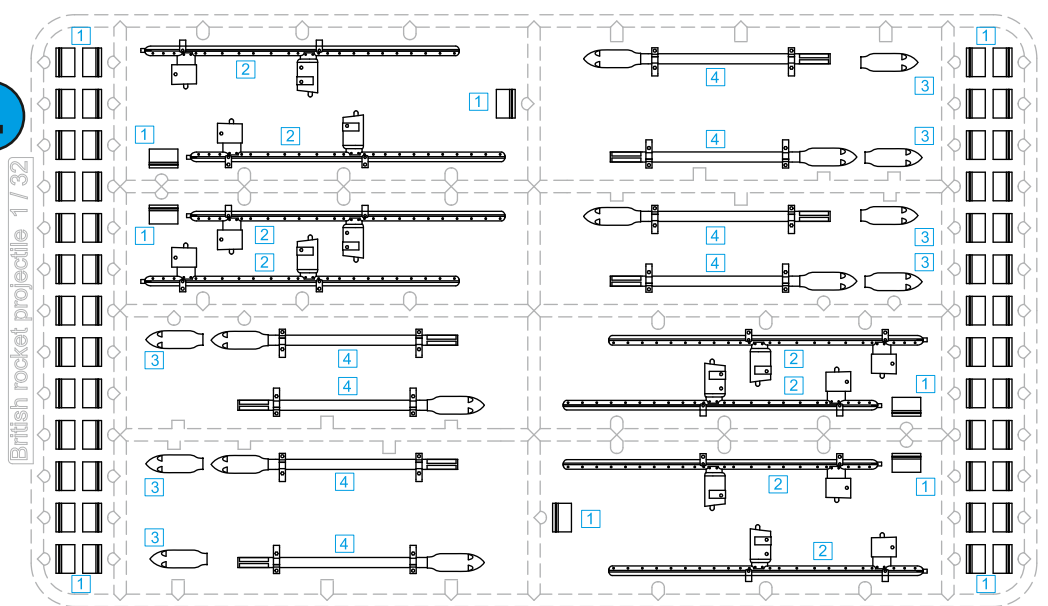
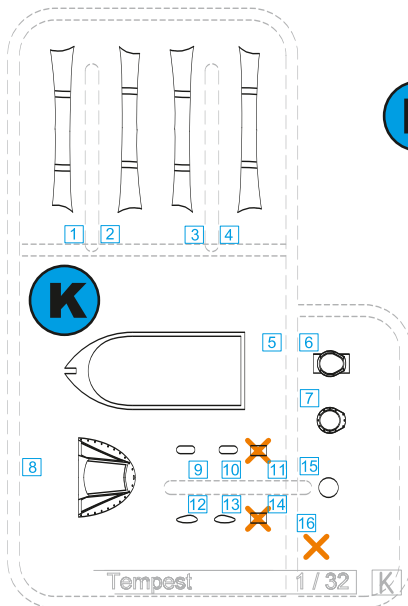

PUR parts
PUR1-PUR37

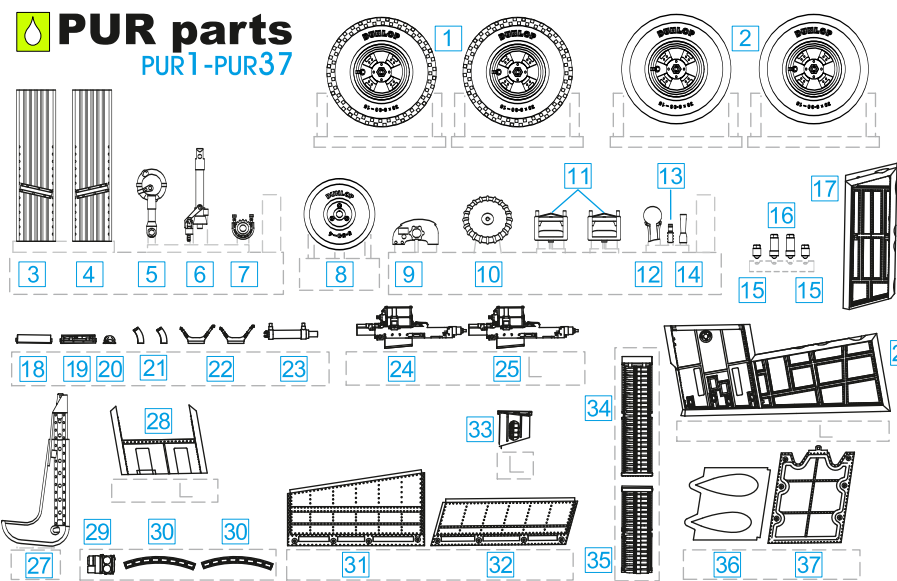

LAS1-LAS8



FILM
paint masks



PHOTO-ETCHED parts
PE1-PE24

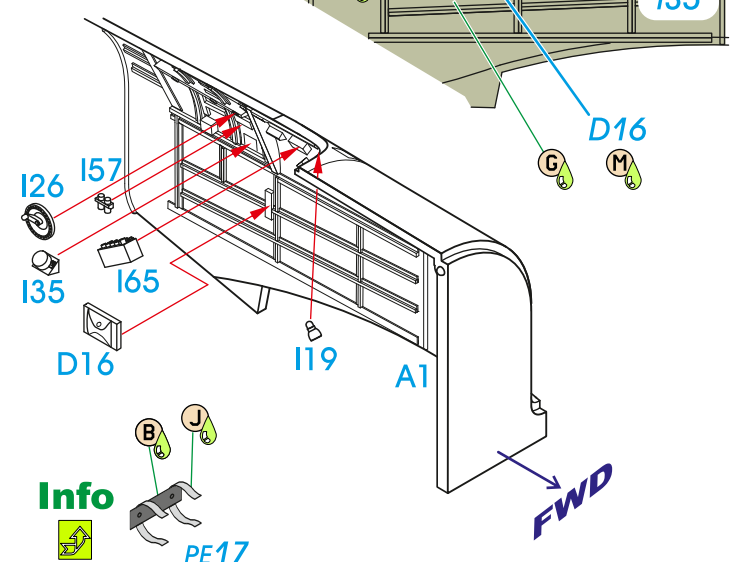
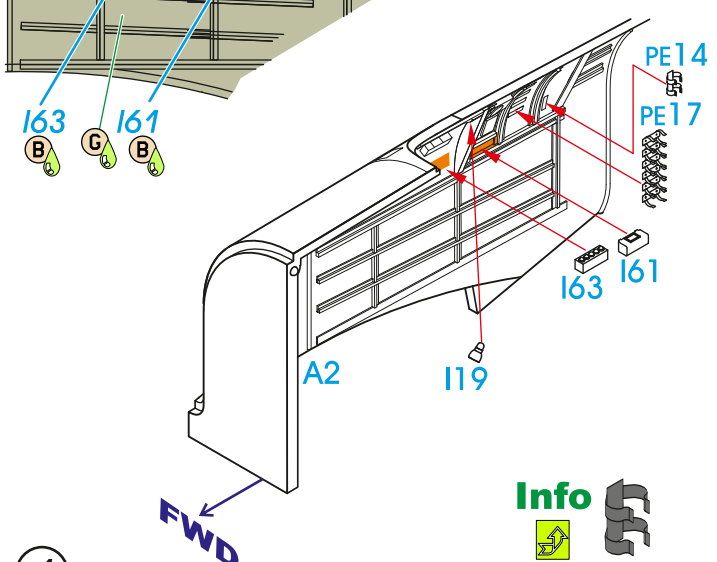
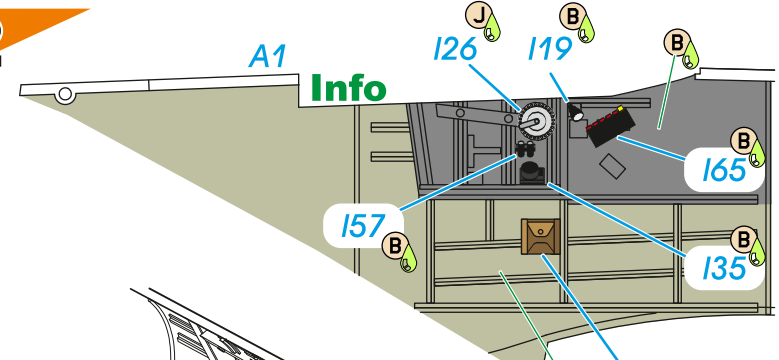
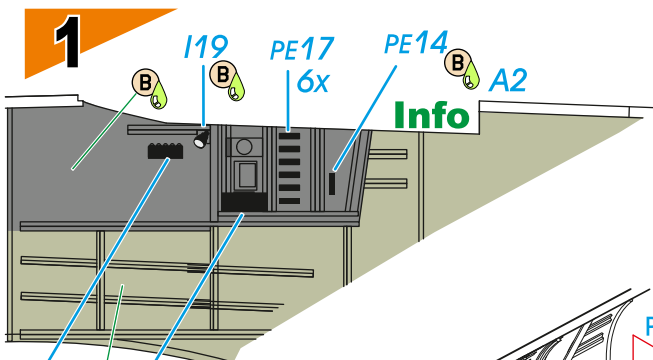
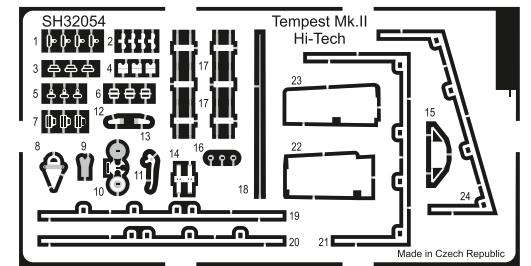

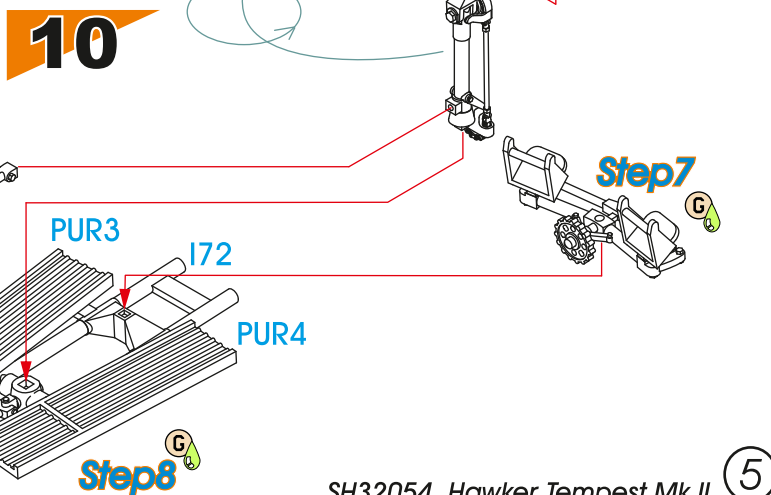
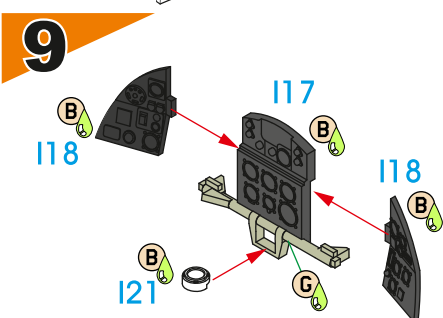
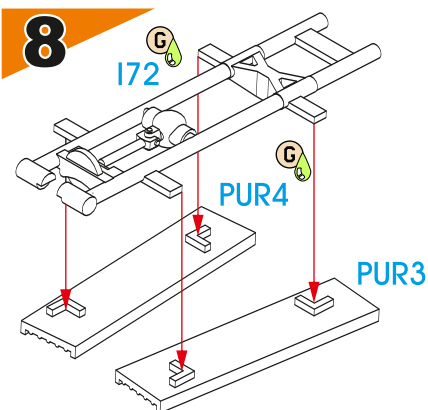
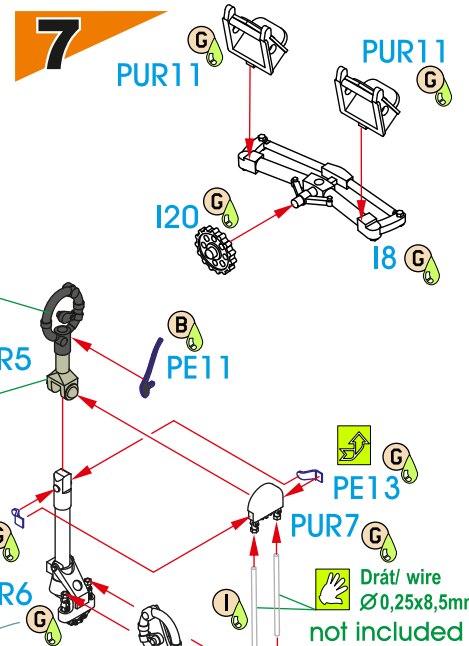
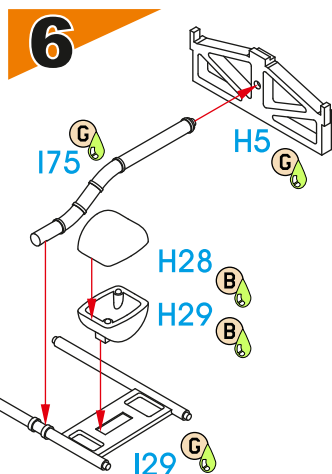
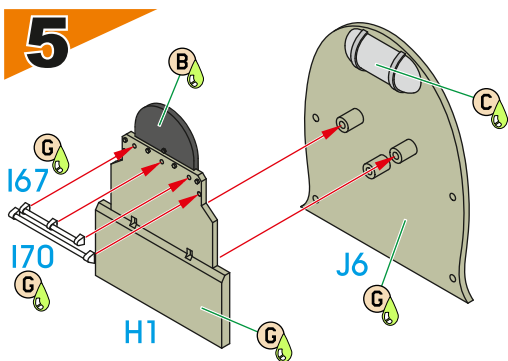
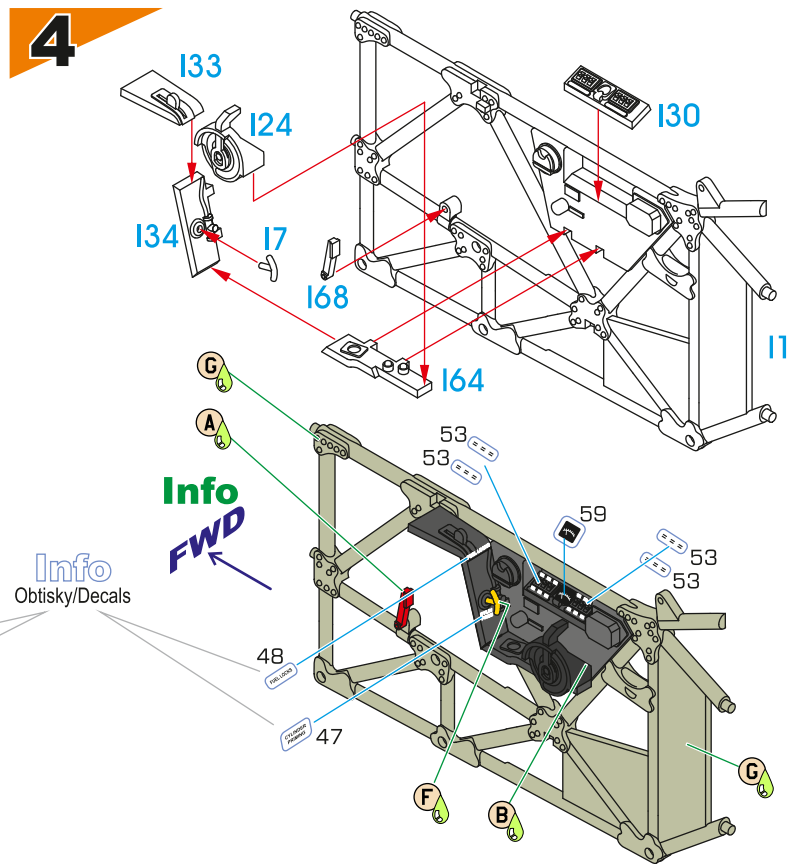
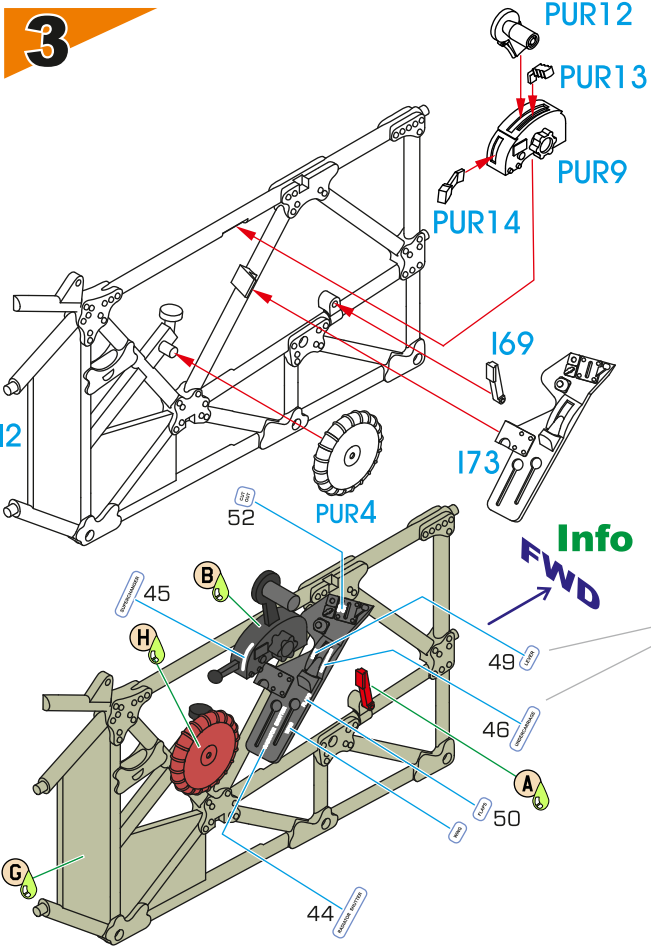

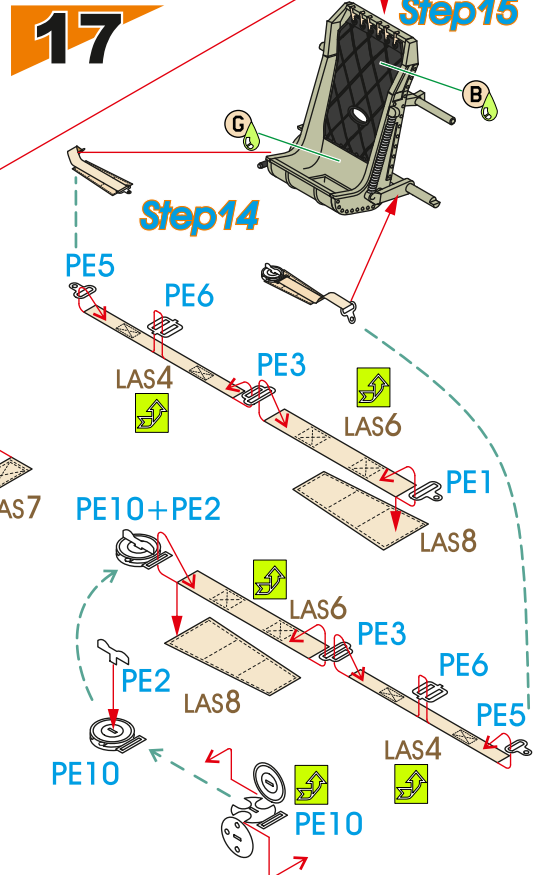
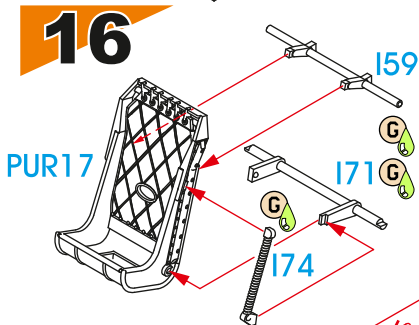
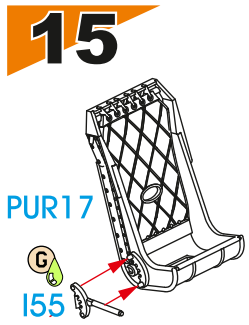
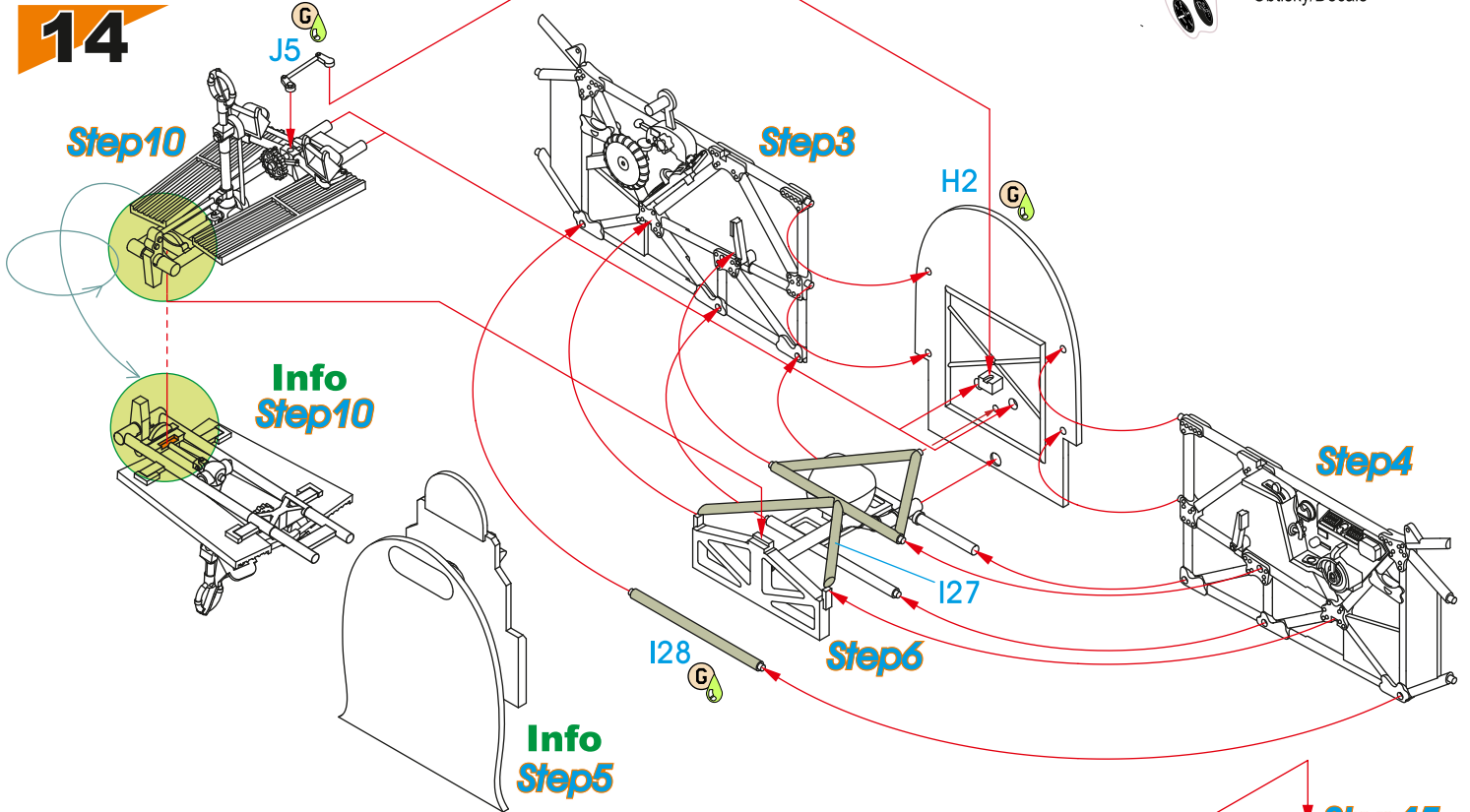
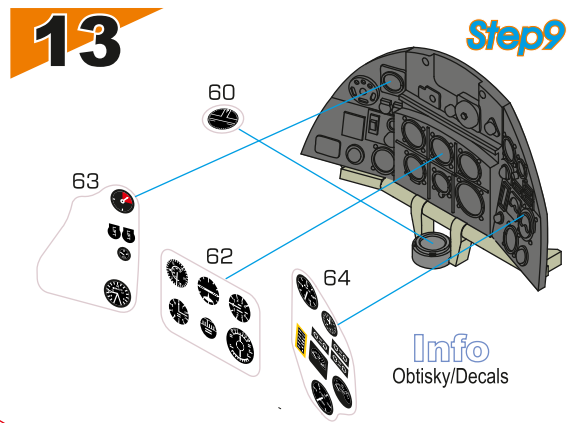
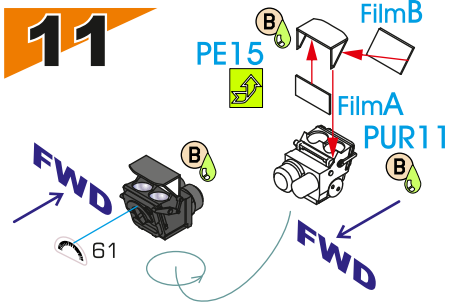

18

Step14

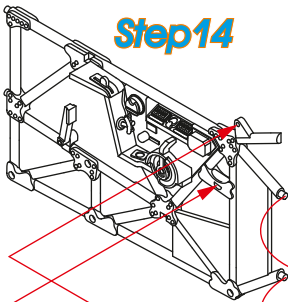

Step17

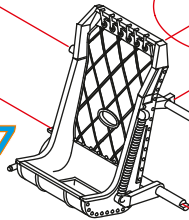

19

Info Step5

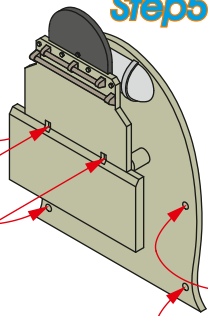

Step14

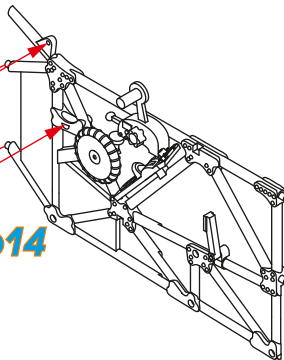

Step13

Step12

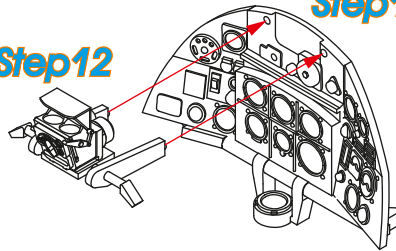

Info

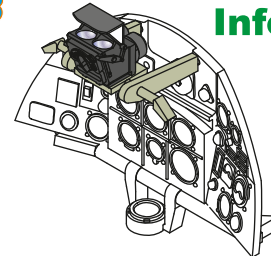

Step17/
page 6

Info for parts LAS1 - LAS8

1. Take the precut textile part out of the sheet.
2. Remove supporting paper.
3. Crumple the belt into a little ball and nedd it between the fingers.
4. Thread the belts through the buckles - use superglue.
5. Put the belts into the seat.
6. Spray by the glossy varnish.
7. Impregnate the belts with very diluted oil color (mix black and brown) - it will highlight the texture.
8. Spray by matt varnish.

After the varnish becomes dry it is possible to drybrush with light oil colour.

Cracks
WWW.HGWMODELS.CZ



20

Step19

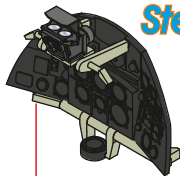

Step14

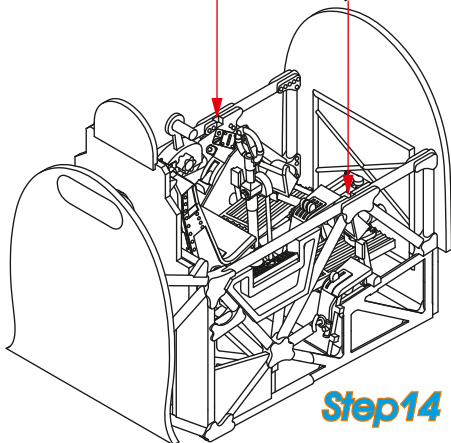

21

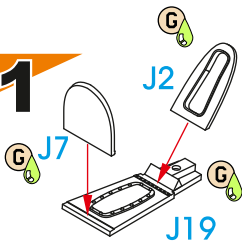

Step21

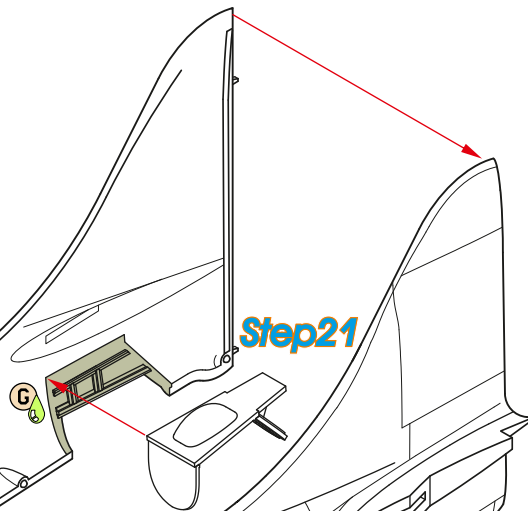

22

Step1

Step2

Step20

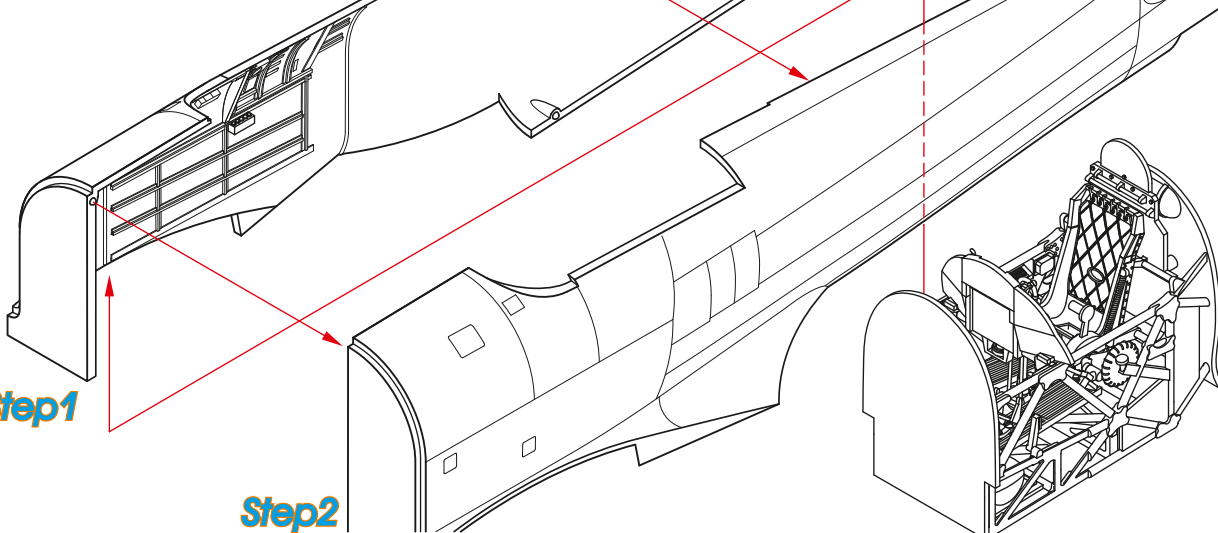

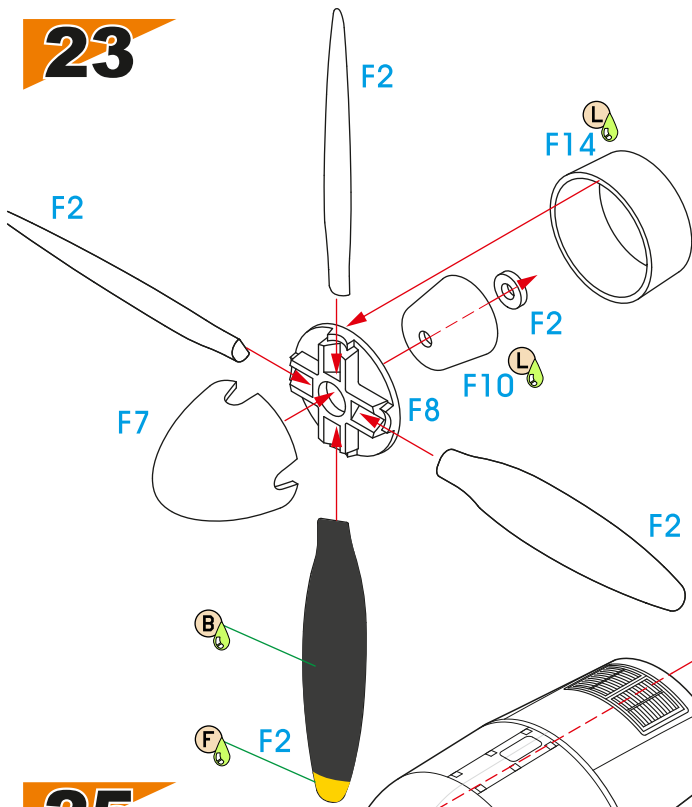
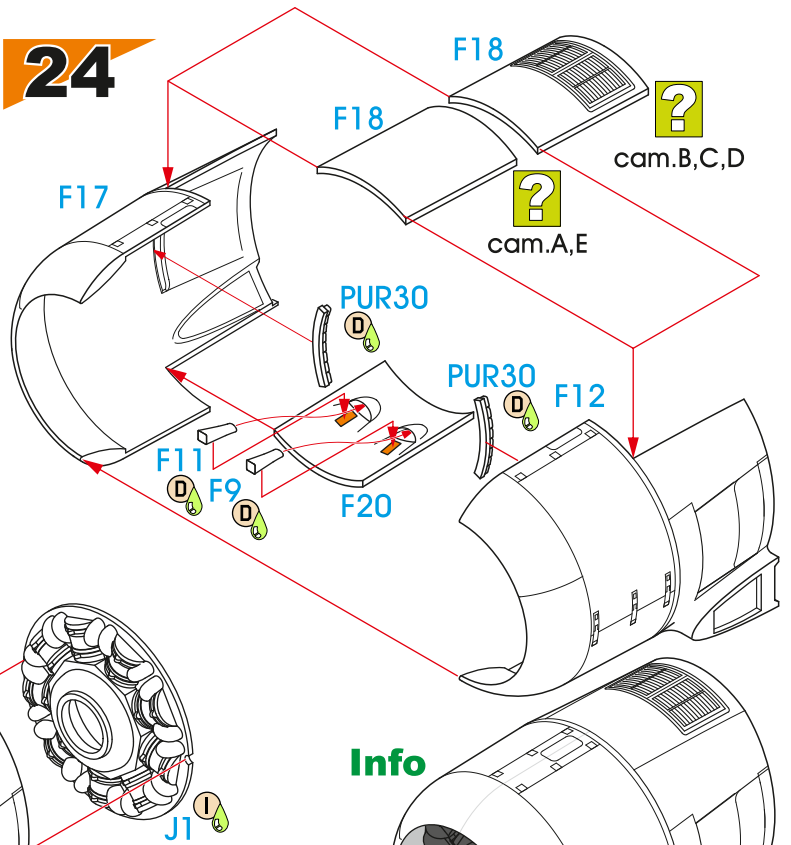
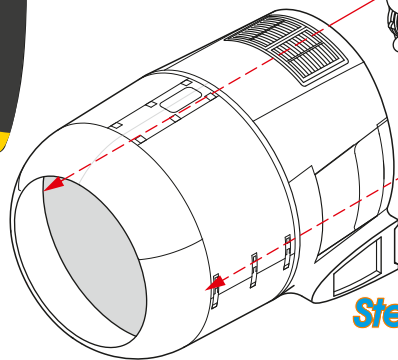
23**24****25****Step24****Info**

Pokračování polí
kamuflážních barev
Painted in the same
pattern as the outside

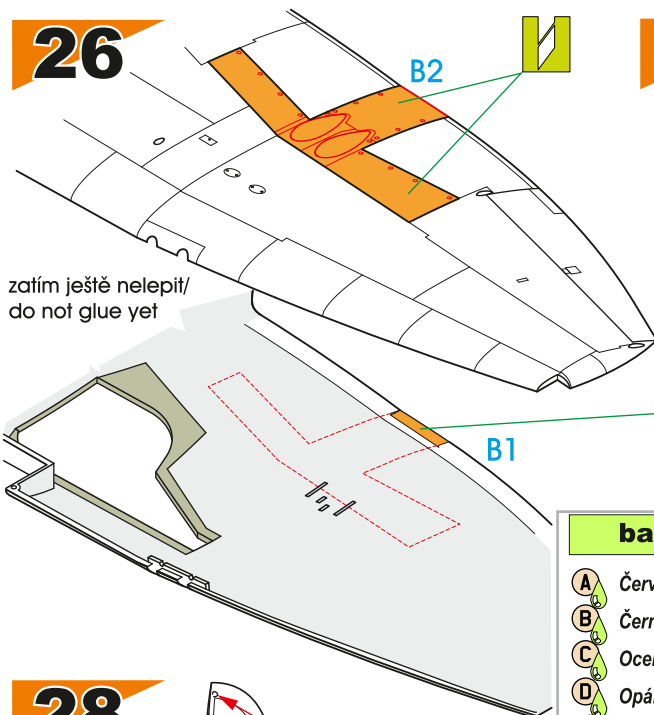
26

zatím ještě nelepit!
do not glue yet

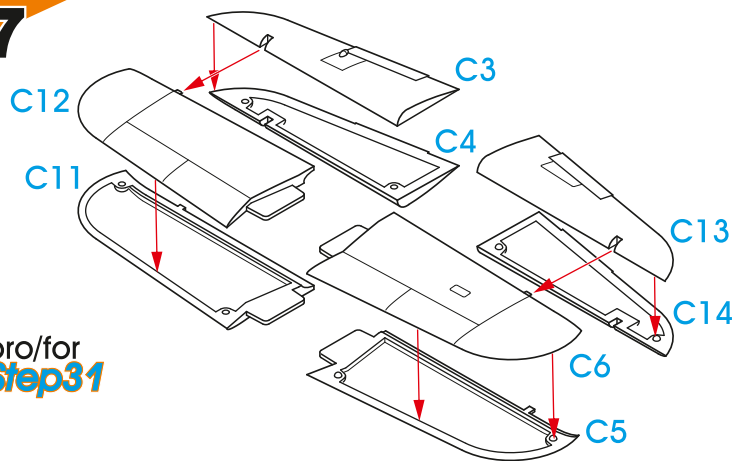
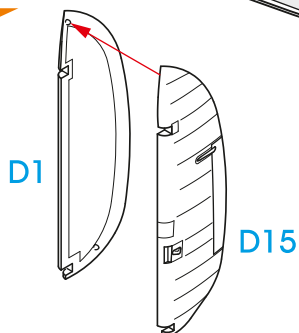
27**pro/for Step31****28****barvy/ colours****GUNZE SANGYO****Alclad II**

A	Červená/ RED	H3/C3	
B	Černá/ BLACK	H12/C33	
C	Ocelová/ STEEL	H18/C28	
D	Opálený kov/ BURNT IRON	H76/C61	ALC123
E	Černá na pneu./ TIRE BLACK	H77/C137	
F	Žlutá/ YELLOW	H329/C329	
G	Šedozelená interiér./ INTERIOR GREY GREEN	H334/C334	ALCE012
H	Červenohnědá/ RED BROWN	H47/C41	
I	Tmavý kov/ DARK IRON	MC214	
J	Hliník/ ALUMINIUM	MC218	ALC101
K	Mosaz/ BRASS	MC219	
L	Motor. šedá/ ENGINE GREY	H339/C339	
M	Barva kůže/ LEATHER	H37/C43	

8

SH32054 Hawker Tempest Mk.II

33

Step32

Info

pohled zespoda/
the bottom view
B1 vynechán/
B1 omitted

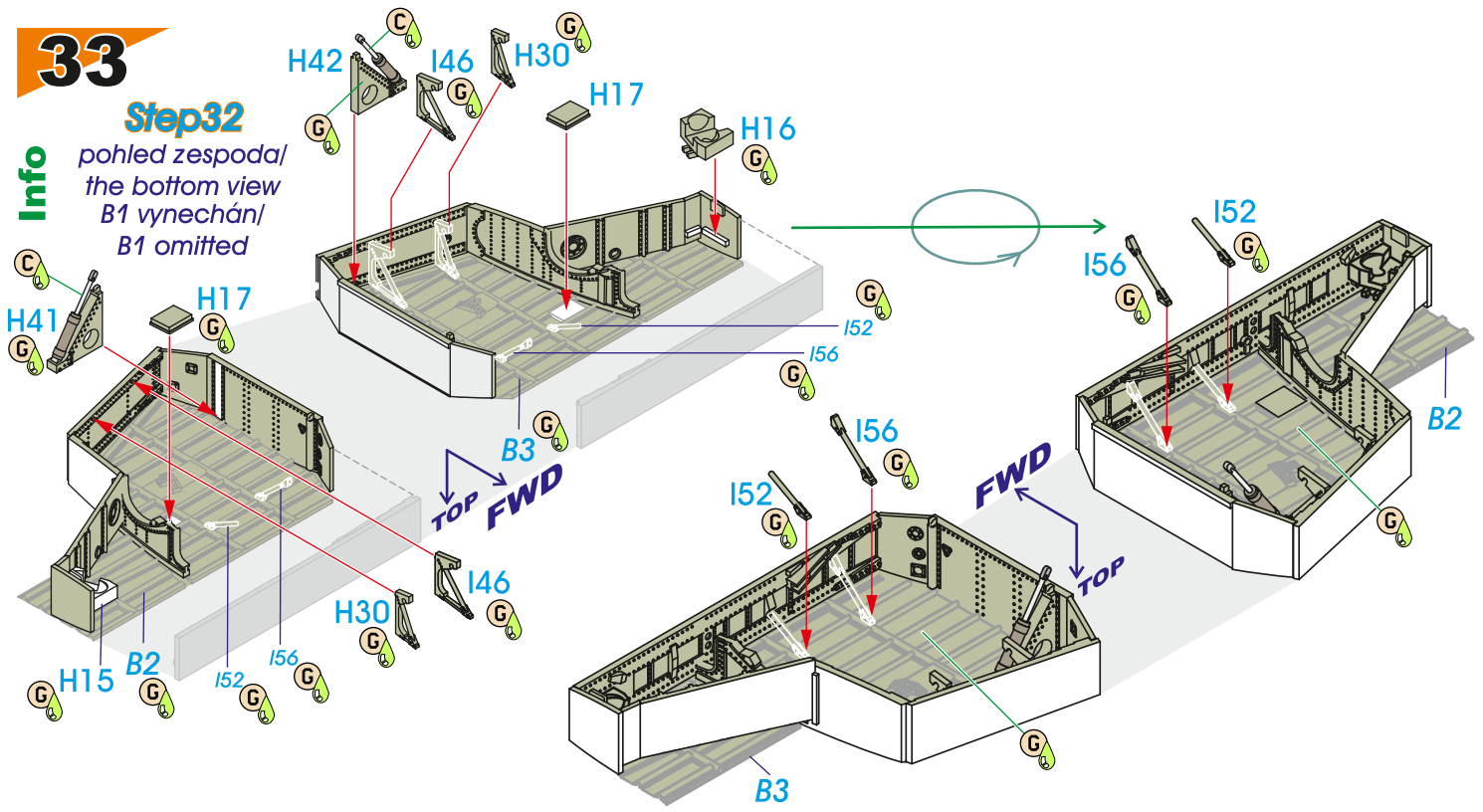

34

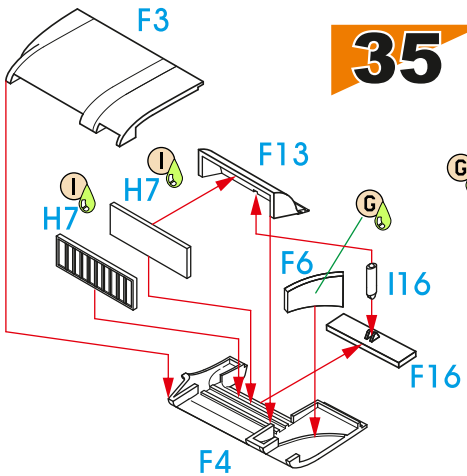

35

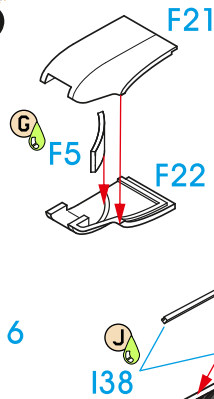

36

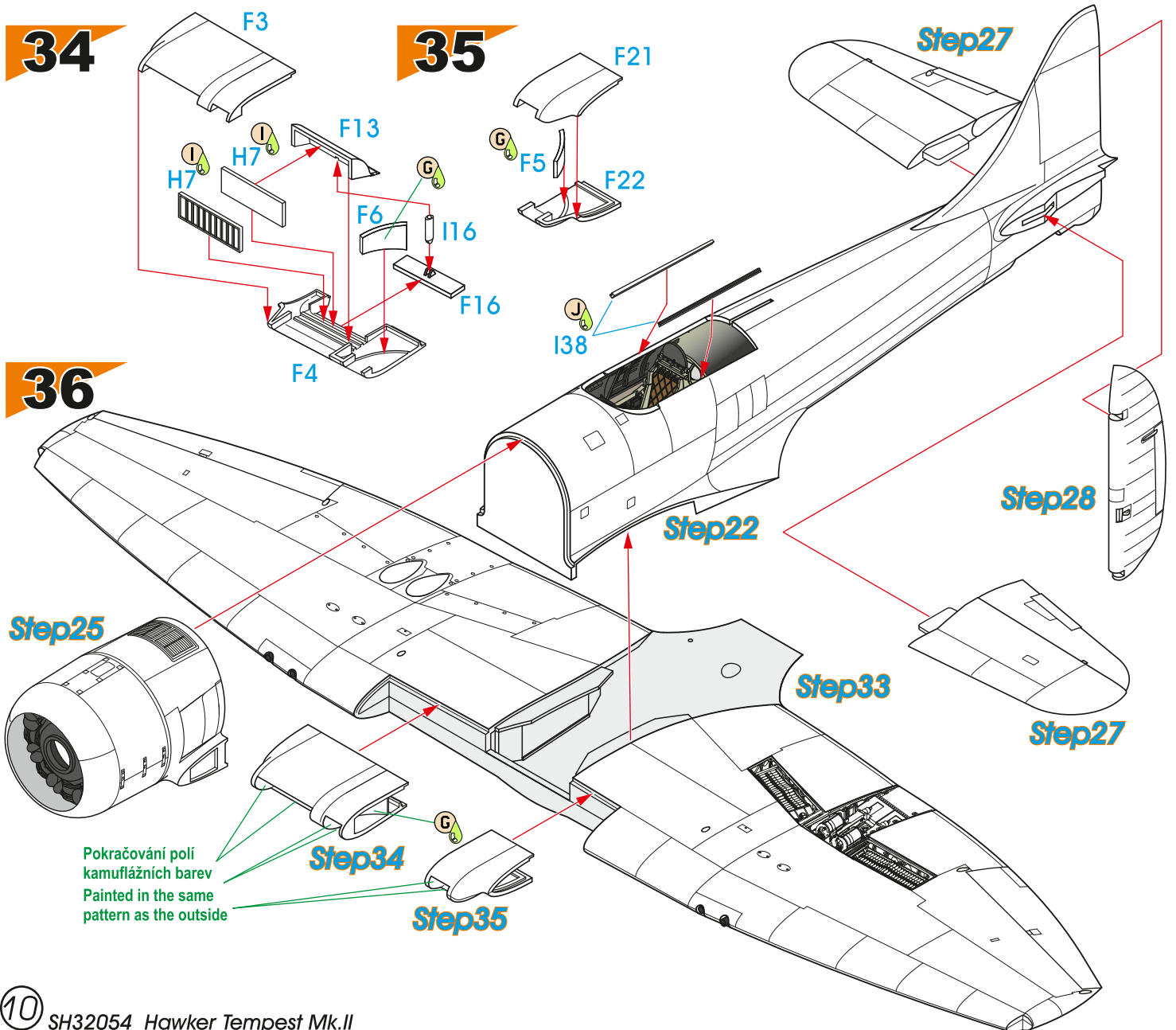

37

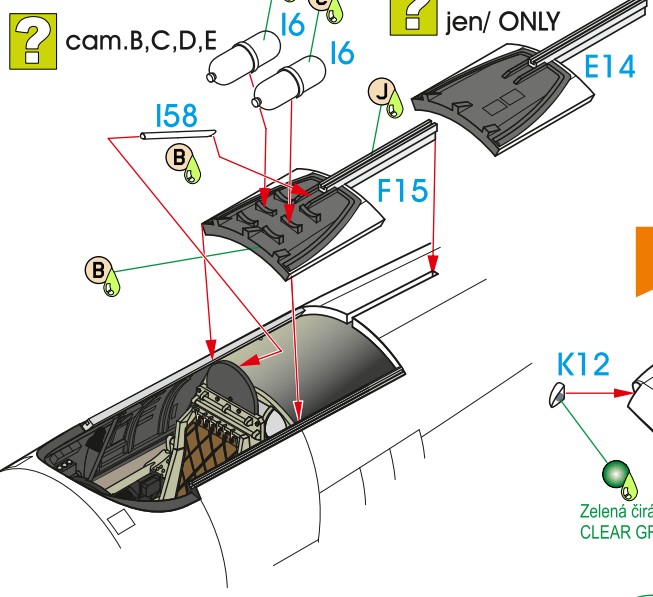

38

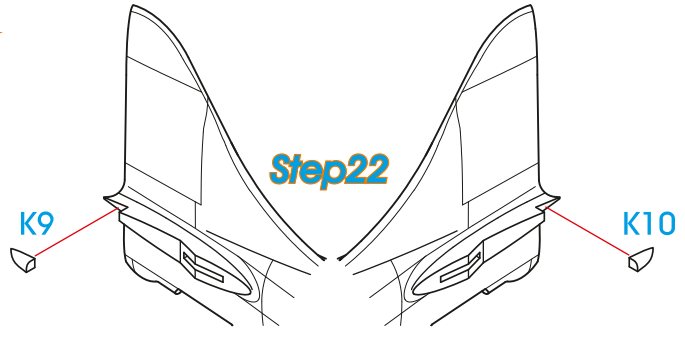

39

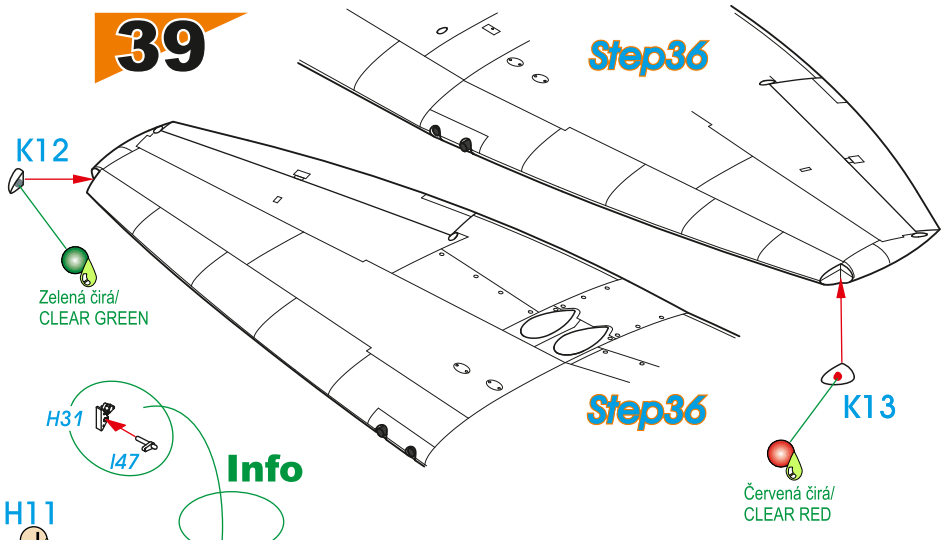

40

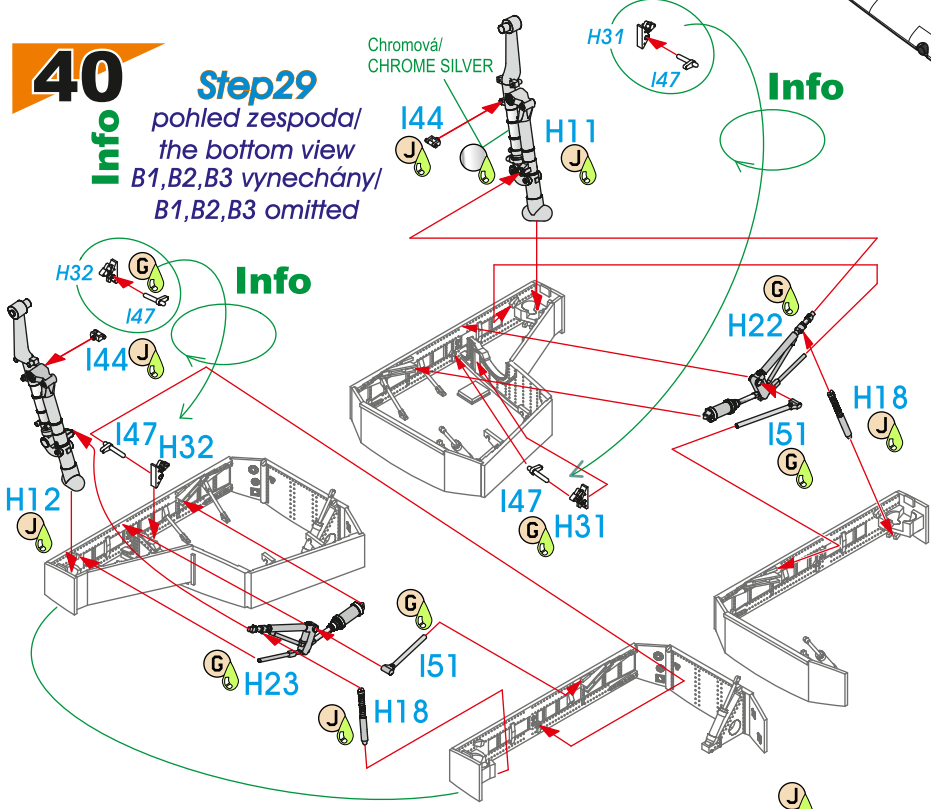

pohled zespoda/
the bottom view
B1,B2,B3 vynechány/
B1,B2,B3 omitted

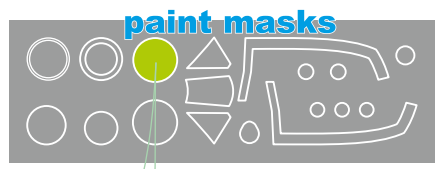

41

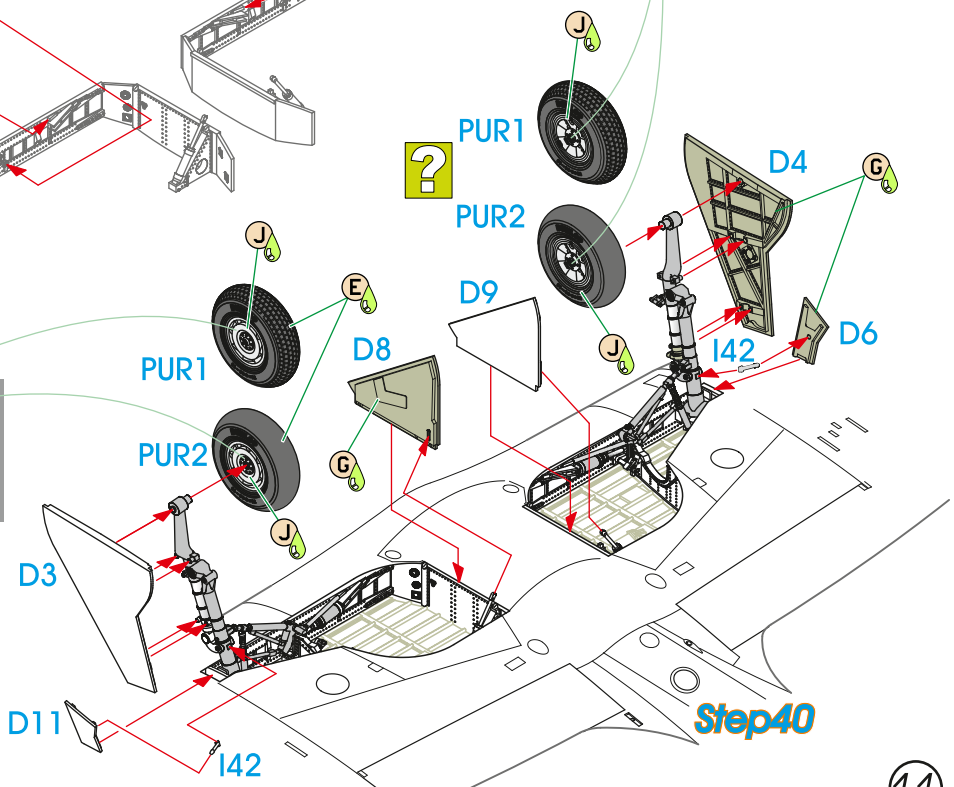
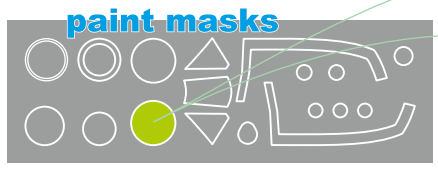

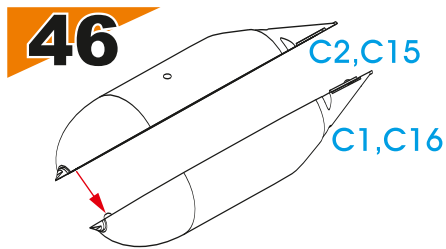
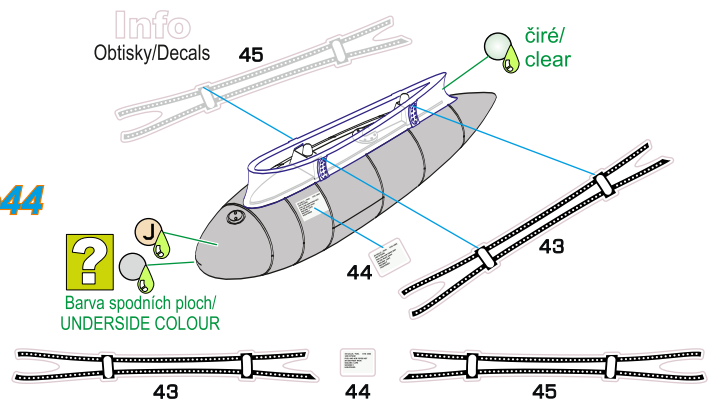
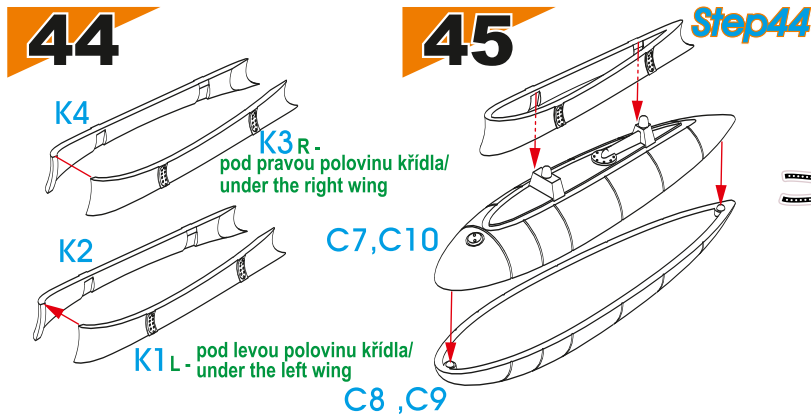
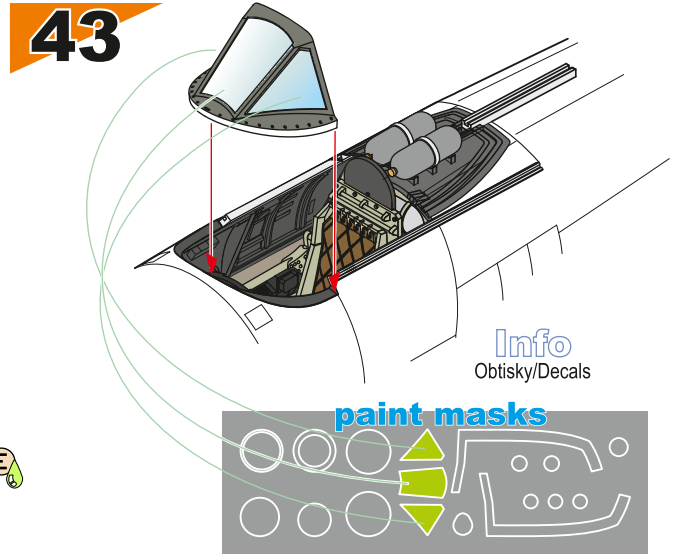
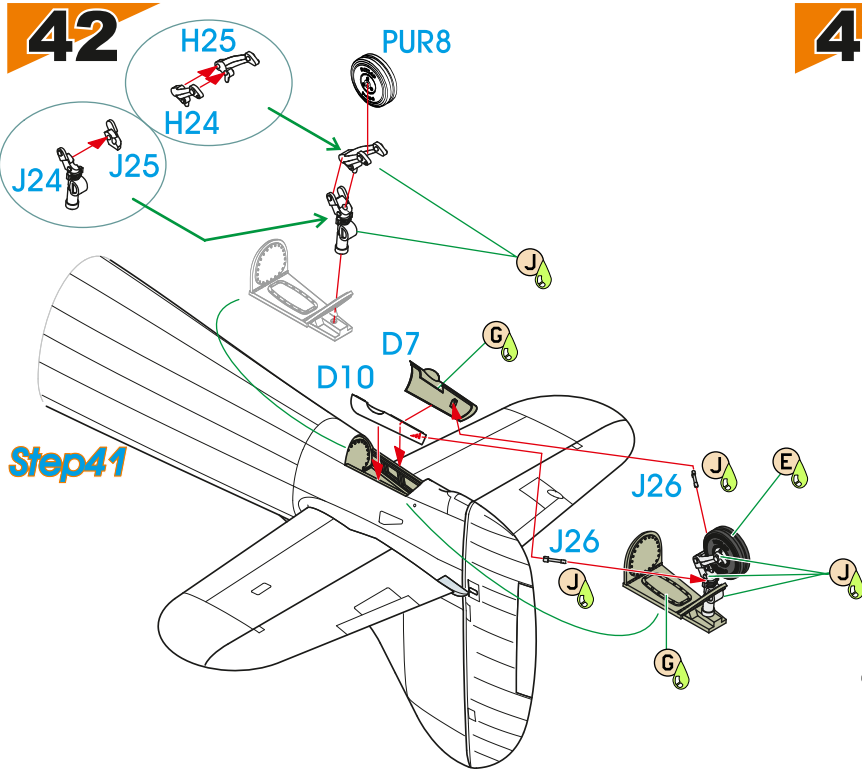

48 ?

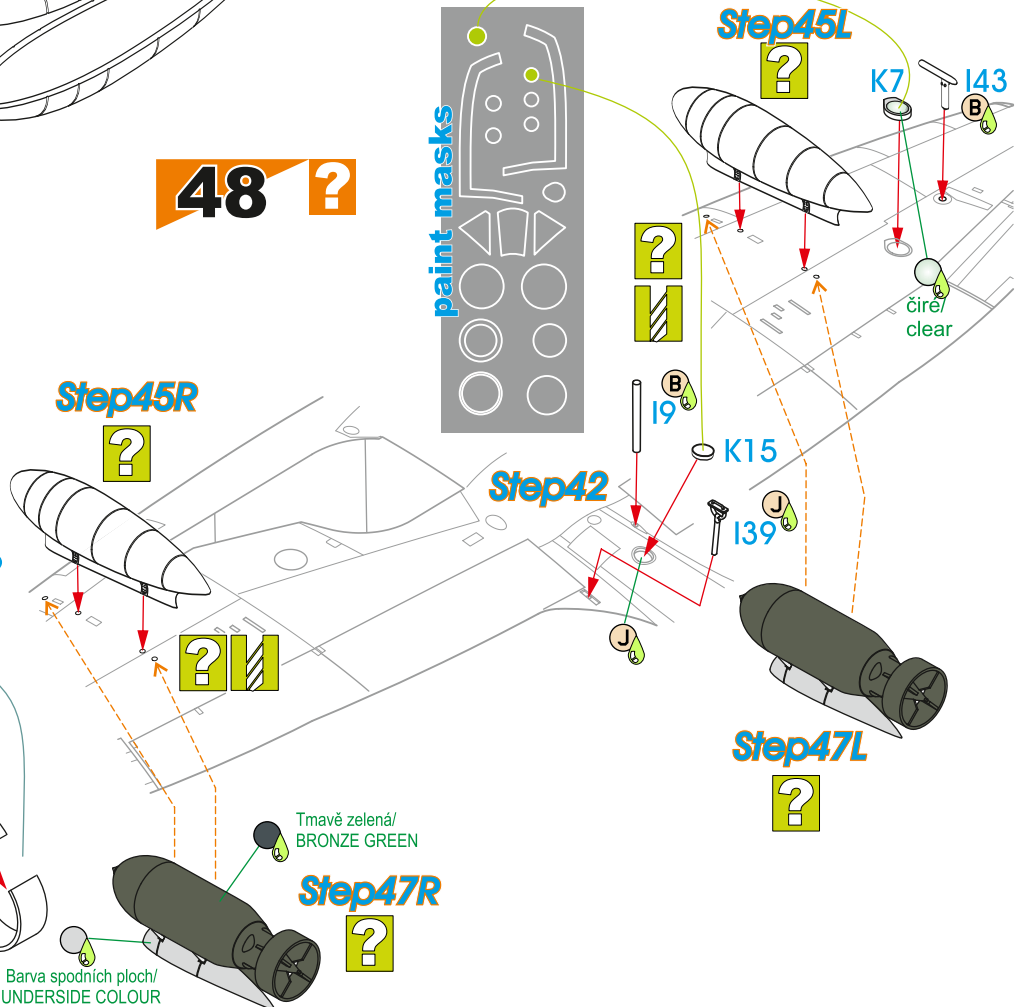
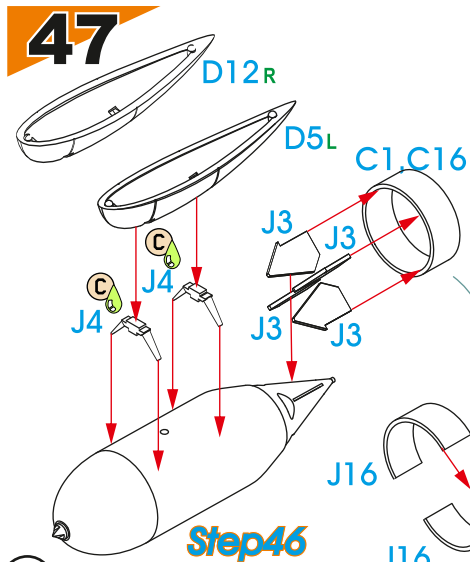

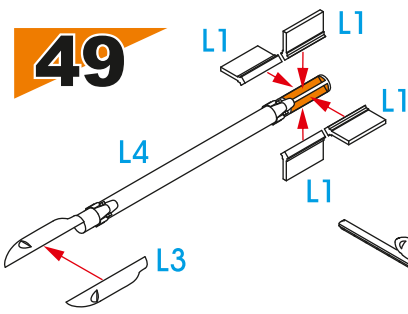

51 ?

Step50
4x

Step50
4x

Step42

50 **Step49**

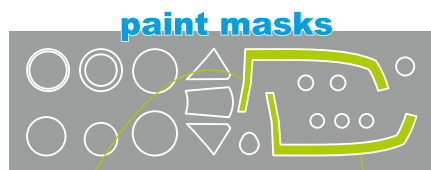
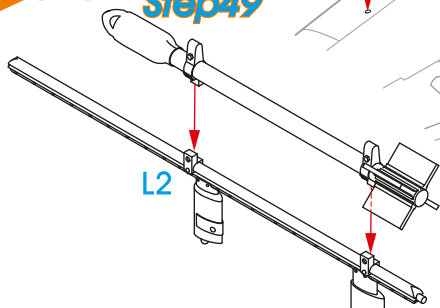

Info

Tmavě zelená/
BRONZE GREEN

Barva spodních ploch/
UNDERSIDE COLOUR

52

PE

Pohyblivé/
movable

K5

PE18

PE16

dorýt linku/
scribe a line

PE

Step23

PUR37
PUR32
PUR36
PUR31

? položit kryty na křídlo/
lay the covers on the wing